

noorth

milldue edition

UPDATE
2016

"It is a mild, mild wind, and a mild looking sky; and the air smells now, as if it blew from a far-away meadow; they have been making hay somewhere under the slopes of the Andes, Starbuck, and the mowers are sleeping among the new-mown hay."

Herman Melville, Moby-Dick, 1851

a fine everyday living

Un approccio sofisticato al mondo del benessere, una visione integrata che mette in simbiosi il progetto d'arredo e l'architettura dell'ambiente bagno, una ricerca continua per mettere in scena i nuovi rituali del vivere contemporaneo: Noorth è una realtà in grado di esprimere un linguaggio evoluto, espressione di una dimensione internazionale ma allo stesso tempo di un'artigianalità tutta italiana. Una collezione oggi arricchita di nuovi componenti che completano la proposta d'arredo complessiva: dai lavabi pensati come soluzioni integrate ai contenitori o come elementi dal forte valore formale e compositivo, dalle nuove finiture interne ai pensili variamente organizzati. Un insieme vasto ed eterogeneo rappresentato in modo puntuale e didascalico, con un sistema di rappresentazione organizzata che si trasforma in uno strumento di consultazione pratico e funzionale. Una proposta che si esprime poi in una serie di soluzioni compositive concrete, valorizzate da accostamenti ricercati, equilibri dimensionali misurati, dialoghi tra forme diverse, tra texture materiche e superfici omogenee, tra riflessi e cromie delicate. Forme pulite, rigorose e minimali ma non per questo asettiche, superfici che rivelano l'essenza più vera dei materiali, accostamenti cromatici ricercati che si integrano in un pensiero architettonico dello spazio nel quale gli elementi principali dell'ambiente bagno dialogano con pavimenti, rivestimenti, illuminazione, tecnologia. Perché Noorth è una realtà evoluta, che supera gli aspetti puramente funzionali per approfondire il tema delle emozioni e dello stare bene in un ambiente curato nei particolari, nel quale il dialogo fra volumi, superfici e linee si traduce in un'eleganza contemporanea e sofisticata.

Noorth may be viewed in many ways: a sophisticated approach to the world of wellness, an integrated vision that harmoniously unites the furnishing project with the bathroom architecture, or an ongoing research program aimed at setting the stage for contemporary life's new rituals. Above and beyond all this, Noorth is a brand that speaks a highly-articulate language, an expression of its international dimension, but at the same time a hallmark of all Italian craftsmanship. Today's collection is enhanced by new additions that complement the overall decor proposal: e.g. the washbasins designed as integrated solutions for storage units, or as furnishing elements with strong formal and compositional value, new interior finishes to variously arranged wall units. A vast and diverse set of items that is represented in an accurate and detailed manner, with an organized system of representation that turns into a practical and functional reference tool. A proposal which is then expressed in a series of concrete compositions, enhanced by sophisticated combinations, well-balanced dimensional poises, dialogues between different shapes and sizes, between substantial textures and homogeneous surfaces, amid delicate reflections and dainty colors. Pure, rigorous and minimal lines without being lifeless, surfaces that reveal the true essence of materials, sophisticated color combinations that blend into an architectural concept of space in which the main elements of the bathroom interact with floors, walls, lighting, and technological features.

This is because Noorth is a highly-evolved brand which reaches beyond purely functional aspects in a quest to explore the theme of emotion and of well-being in an environment in which care for detail and a strong interaction among volumes, surfaces and lines all contribute to creating an atmosphere of contemporary and sophisticated elegance.

Une approche sophistiquée du monde du bien-être, une vision intégrée mettant en symbiose le projet d'ameublement et l'architecture de la salle de bain, une recherche constante de mise en scène des nouveaux rituels de l'habitat contemporain : Noorth parvient à exprimer un langage évolué, expression à la fois d'une dimension internationale et d'un savoir-faire artisanal 100 % italien. La collection s'enrichit aujourd'hui de nouveaux éléments qui viennent compléter notre gamme de produits d'ameublement : des lavabos - étudiés comme solutions intégrées aux éléments de rangement ou comme meubles se distinguant en termes de forme et de composition - aux nouvelles finitions intérieures en passant par des éléments muraux diversement agencés. Un éventail vaste et hétérogène exposé de manière précise et avec de nombreuses légendes dans le cadre d'une présentation qui se transforme en outil de consultation particulièrement pratique et fonctionnel. Notre offre de produits s'exprime aussi à travers une série de solutions de composition concrètes mises en valeur par des associations recherchées, des équilibres dimensionnels parfaits, des dialogues entre des formes diverses, entre des textures matérielles et des surfaces homogènes, entre des reflets et des couleurs délicates. Noorth se distingue par ses formes éthérées, rigoureuses et minimalistes - sans jamais être aseptisées - ses surfaces qui révèlent l'essence la plus intime des matériaux, ses associations raffinées de couleurs qui s'inscrivent dans une conception architecturale de l'espace où les principaux éléments de la salle de bain interagissent avec les sols, les revêtements, l'éclairage et la technologie. Car Noorth est une marque d'avant-garde qui dépasse les aspects purement fonctionnels pour approfondir le thème des émotions et du bien-être dans un espace pensé dans les moindres détails où le dialogue entre volumes, surfaces et lignes se traduit par une élégance contemporaine et sophistiquée.

Eine Vertiefung mit dem Konzept Wellness, eine integrierte Betrachtungsweise, die Einrichtungslösungen mit der Gestaltung des Bades in Einklang bringt, eine fortwährende Auseinandersetzung mit den täglichen Gewohnheiten des Lebensstils von heute: dies alles ist Noorth, ein Unternehmen, das globale Ausdrucksformen des Fortschritts verschmolzen mit dem typischen italienischen kunsthandwerklichen Geschick perfekt umzusetzen weiß. Die Kollektion der Gegenwart wird bereichert durch neue Einrichtungsobjekte, die allumfassende Einrichtungslösungen abrunden: dazu gehören Waschbecken, die als Vervollständigung von Behältnissen oder als Einrichtungs-elemente wirkungsvoller Formgestaltung und Kombinationsmöglichkeiten konzipiert worden sind, aber auch neue vielseitig einsetzbare Hängeschränke. Der Katalog zeigt auf präzise und übersichtliche Weise ein breitgefächertes und vielseitiges Angebot für die Einrichtung und Gestaltung des Bades und erweist sich als praktisches und zweckdienliches Nachschlagewerk. So präsentiert er eine Reihe von konkreten Gestaltungsideen, die durch geschmackvoll gewählte Kombinationen, Abstimmungen von Größen und Formen, Materialien, Oberflächenausführungen, Glanzeffekten und Farben zusätzlich an Ausdruckskraft gewinnen. Es sind reine, sich aufs Wesentliche beschränkende, aber deshalb keineswegs steril wirkende Formen, die die wahre Wesensart der gewählten Materialien sichtbar werden lassen, und erlesene farbliche Kontraste der Einrichtungsobjekte des Bades als Bestandteil der Raumgestaltung in ein genau durchdachtes Wechselspiel mit dem Fußboden, der Wandbekleidung, der Beleuchtung und der eingesetzten Technologie bringen. Noorth setzt fortschrittliche Gestaltungsideen um, die Emotionen auslösen und mehr als nur perfekte Funktionalität aufweisen, die für das Wohlbefinden in einem aufs kleinste Detail geplanten Ambiente sorgen, sondern auch ein Gesamtbild an Volumen, Oberflächen und Linien schaffen, das die Eleganz des Raumes ausmacht.

Утонченный подход к миру хорошего самочувствия, интегрированное видение, заключающееся в симбиозе дизайна и архитектуры ванной комнаты, продолжающийся поиск новых ритуалов современной жизни: Noorth - это реальность, способная поддерживать с покупателями непрерывный диалог, характеризующаяся международным масштабом деятельности и чисто итальянским мастерством. Коллекция обогащается новыми компонентами, которые дополняют предлагаемые предметы интерьера: от раковин, разработанных в качестве интегрированных решений, до шкафчиков для хранения или элементов с четко определенными формами и композициями, от новых внутренних отделок до подвесных шкафчиков с различным расположением. Обширная и разнообразная подборка предметов точно и подробно описана и представлена в виде организованной системы, которая превращается в практичный и функциональный справочный инструмент. Предлагаемый ассортимент выражается в ряде конкретных композиций, улучшенных продуманными сочетаниями, выверенными размерными решениями, ведущими диалог между различными формами, материальными текстурами и однородными поверхностями, отражениями и пастельными тональностями. Чистые формы, строгие и минималистские, при этом не асептические, поверхности, раскрывающие истинную сущность материалов, сложные цветовые сочетания, интегрирующиеся в архитектурную концепцию пространства, где основные элементы ведут творческий диалог с покрытием полов, стен, технологиями и освещением. Noorth является усовершенствованной реальностью, превосходящей чисто функциональные аспекты помещения, вступая в область эмоций и хорошего самочувствия, благодаря особому вниманию к деталям, сочетанию объемов, поверхностей и линий, создавая современную и утонченную элегантность.

discover
two new
solutions
for your
home

COLLECTION

THE

first chapter interiors



Un concept essenziale e rigoroso definito da geometrie perfette e assolute, volumi puri e unitari. Nella collezione Zenit i lavabi rettangolari e i contenitori laccati nella tonalità grafite danno vita a blocchi compatti, idealmente collegati dalla particolare consolle in essenza. Una soluzione che crea un impianto d'arredo ordinato, simmetrico, completato dalla presenza dei due contenitori attrezzati. Una proposta formalmente essenziale, valorizzata dalla qualità dei dettagli costruttivi e dalla scelta delle finiture e delle soluzioni tecniche adottate.

An essential and rigorous concept marked by perfectly absolute geometries, neat and unbroken volumes. In the Zenit collection rectangular basins and lacquered storage units in graphite hues give rise to compact blocks, ideally linked up by the exclusive veneer console. A solution that creates a well-ordered, symmetrical interior decoration concept, complemented by the presence of two lavishly equipped columns. A furnishing proposal that, while stylistically essential, is enhanced by the quality of the construction details and the choice of finishes and technical solutions.

Un concept essentiel et rigoureux défini par des géométries parfaites et absolues, des volumes purs et unitaires. Dans la collection Zenit, les lavabos rectangulaires et les éléments de rangement laqués couleur graphite génèrent des blocs compacts, idéalement reliés par la particularité de la console en bois. Une solution qui donne naissance à un ameublement ordonné et symétrique que complètent deux éléments de rangement muraux entièrement équipés. Une proposition dont la forme essentielle est sublimée par la qualité des détails de construction et par la choix des finitions et des solutions techniques adoptées.

Ein sich auf das Wesentliche beschränkendes Konzept mit einer perfekten geometrischen Linienführung, klaren und eine Einheit bildenden Volumen. Die rechteckigen Waschbecken der Kollektion und im Farbton Graphite lackierten Behältnissen bilden kompakte Quader, die eine besondere Verbindung mit der Konsole, ebenfalls unverkennbarer Bestandteil des Raumes, eingehen. Eine Gestaltungsidee, die die Grundlage einer symmetrischen, perfekt abgestimmten Einrichtungsanordnung bilden, die durch zwei Hängebehältnisse abgerundet wird, und zugleich eine formschöne, auf das Detail, die richtige Auswahl an Oberflächengestaltungen und auf technische Funktionalität achtende Lösung darstellt.

Строгая и простая концепция, определяемая безупречными и абсолютными геометрическими формами и чистыми объемами. Коллекция Zenit включает прямоугольные раковины и лакированные шкафчики оттенка графита, образуя компактные блоки, идеально соединенные особой консолью из древесины. Решение, создающее аккуратный, симметричный интерьер, дополненный двумя подвесными оборудованными шкафчиками. Простое по форме решение, чья ценность заключается в качестве конструктивных деталей и выборе отделки, а также используемых технических решениях.











Sopra e a sinistra: consolle serie Bali in poro Rovere Carbone. | Above and left: Bali console in open pore Carbone oak. | Ci-dessus et à gauche : console série Bali en Rovere Carbone à pores ouverts. | Oben und links: Konsole Serie Bali aus offenporiger Steineiche im Farbton Carbone. | Вверху и слева: консоль серии Bali из пористого дуба Carbone.



Sopra e a destra: colonne con struttura, vani a giorno e ante in laccato Grafite opaco.
 Above and right: columns with open shelving, frame and doors in Grafite matt lacquer.
 Ci-dessus et à droite : colonnes avec structure, niches ouvertes et portes en laqué Grafite mat.
 Oben und rechts: Säulen mit Korpus, türlosen Regalen und Türflügeln mit Lackoberfläche im Farbton Grafite matt.
 Вверху и справа: вертикальные шкафчики со структурой, с открытыми отсеками и створками из лакированного матового материала Grafite.

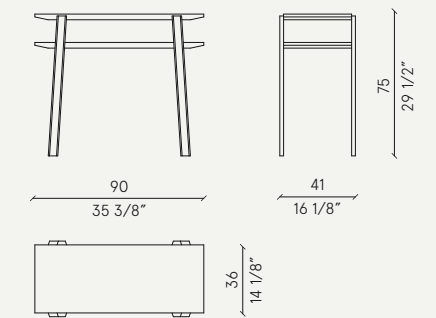
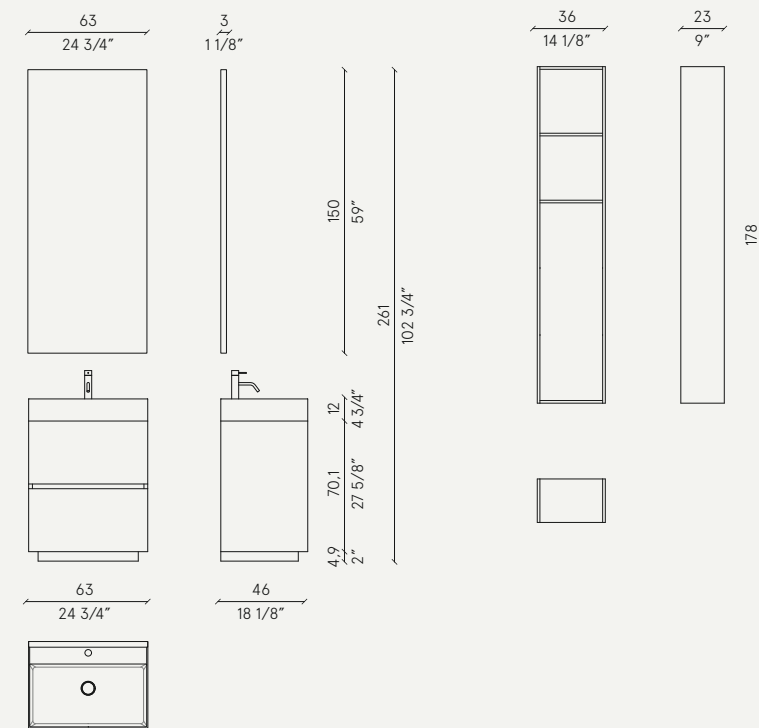
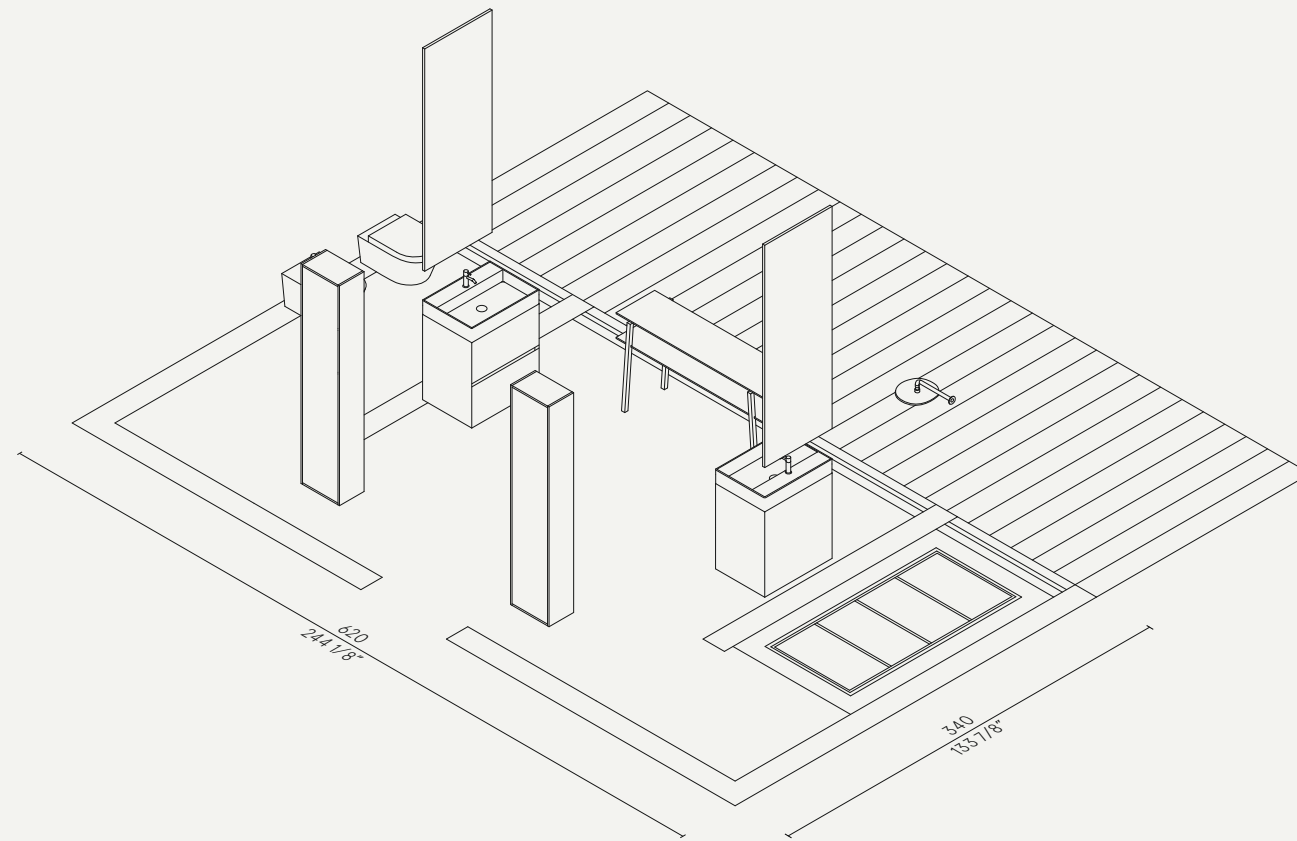

doccia Line | Line shower | douche Line | Duschteller Line | душа Line

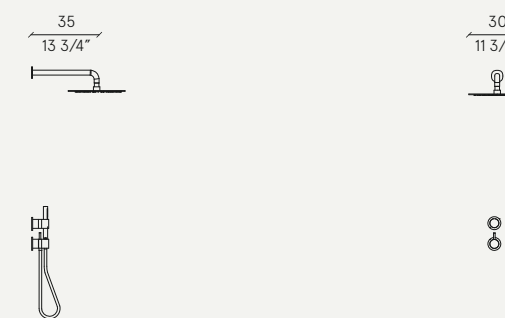

sanitari Senna | Senna sanitaryware | sanitaires Senna | Sanitäranlagen Senna | сантехника Senna

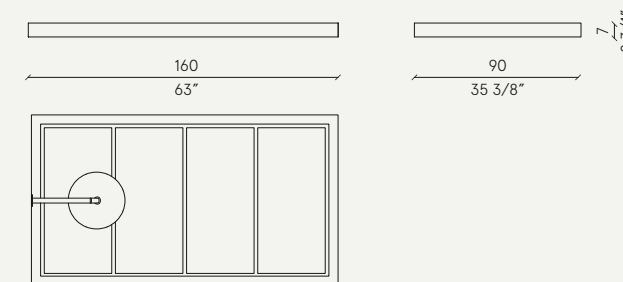
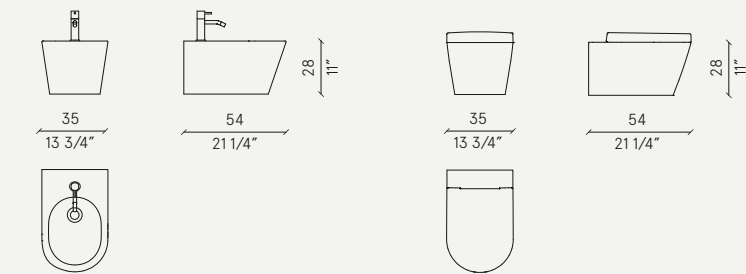

Basi con gola centrale in laccato Grafite opaco con lavabo Man 63 in Milltek. Specchiera sp.3 con retroilluminazione a led inferiore. Colonne con struttura, vani a giorno e ante in laccato Grafite opaco. Console serie Bali. Piatto doccia Line in Milltek. Sanitari Senna in ceramica opaca. Rubinetteria Flow in acciaio inox satinato. | Bases with central groove in Grafite matt lacquer with Man 63 washbasin in Milltek. Lower LED-backlit th.3 mirror. Columns with open shelving, frame and doors in Grafite matt lacquer. Bali console in open pore Carbone oak. Line shower tray in Milltek. Senna glossy ceramic sanitaryware. Flow taps in brushed stainless steel. | Bases à gorge centrale en laqué Grafite mat avec lavabo Man 63 in Milltek. Miroir ép.3 rétroéclairage led sur le bas. Colonnes avec structure, niches ouvertes et portes en laqué Grafite mat. Consoles série Bali en Rovere Carbone à pores ouverts. Bac à douche Line en Milltek. Sanitaires Senna en céramique mate. Robinetterie Flow en acier inox satiné. | Unterbauten mit zentral angebrachter Aussparung mit Lackoberfläche im Farbton Grafite matt mit Waschbecken Man 63 aus Milltek. Wandspiegel Di. 3 mit Led-Hintergrundbeleuchtung im unteren Bereich. Säulen mit Korpus, türlosen Regalen und Türflügeln mit Lackoberfläche im Farbton Grafite matt. Konsole Serie Bali aus offenporiger Steineiche im Farbton Carbone. Duschteller Line aus Milltek. Sanitäranlagen Senna aus matter Keramik. Wasserhähne Flow aus satiniertem Edelstahl. | Основания с центральным углублением из лакированного матового материала Grafite с раковиной Man 63 из Milltek. Зеркало толщ.3 с нижней светодиодной подсветкой. Вертикальные шкафчики со структурой, с открытыми отсеками и створками из лакированного матового Grafite консоль серии Bali из пористого дуба Carbone. Поддон для душа Line из Milltek. Сантехника Senna из матовой керамики. Смесители Flow из сатирированной нержавеющей стали.

Un dialogo tra ampie superfici specchianti sottolineato da un sistema di illuminazione integrato, un gioco di volumi rigorosi ed essenziali sui quali trovano posto lavabi dalle geometrie perfette e assolute. Una composizione originale, risultato dell'estrema flessibilità del sistema Sintesi, sottolineata dalla libera combinazione con un'ampia gamma di lavabi diversi per forma e dimensione. Una proposta impreziosita dalla combinazione tra la matericità della finitura poro Rovere Carbone, la laccatura Castoro opaco e la superficie compatta di Milltek.

An interactive play between large mirrored surfaces enhanced by an integrated lighting system, a game of rigorous and essential volumes upon which stand washbasins with stunningly perfect and strict geometries. An original composition, born out of the extreme flexibility of the Sintesi system, emphasized by the free combination with a wide range of washbasins in different shapes and sizes. A proposal enhanced by juxtaposing the materiality in open pore Carbone oak, Castoro matt lacquer, and the compact Milltek surface.

Dialogue entre de vastes surfaces en miroir souligné par un système d'éclairage intégré, un jeu de volumes rigoureux et essentiels qui accueillent des lavabos aux géométries parfaites et absolues. Une composition originale, fruit de l'extrême flexibilité du système Sintesi, mise en valeur par la possibilité de choisir entre une riche gamme de lavabos différents en termes de formes et de dimensions. Une solution sublimée par le mariage de la matérialité de la finition chêne Carbone à pores ouverts, du laquage Castoro mat et de la surface compacte de Milltek.

Ein Wechselspiel zwischen großzügig bemessenen Spiegelflächen, die durch die integrierte Beleuchtung zusätzliche an Ausdruckskraft gewinnen, eine wohl durchdachte Anordnung von sich aufs Wesentliche beschränkenden Volumen, in dem Waschbecken von perfekter geometrischer Form Platz finden. Eine originelle Komposition, Ergebnis des vielseitig nutzbaren Systems Sintesi, bei dem eine Vielzahl in Form und Größe unterschiedlicher Waschbecken eingesetzt werden können. Eine Lösung, die durch die Kombination der besonderen Oberflächenausführung aus offenporiger Steineiche im matt gehaltenen Farbton Castoro und den kompakten Fläche aus Milltek zusätzlich veredelt wird.

Диалог больших зеркальных поверхностей, подчеркнутый интегрированной системой освещения, игра строгих и простых объемов, на которых размещаются раковины с совершенными и абсолютными геометрическими формами. Оригинальная комбинация, являющаяся следствием необычайной гибкости системы Sintesi, подчеркнутая свободным сочетанием с широким спектром раковин, отличающихся по форме и размеру. Этот вариант усиливается сочетанием материалности отделки пористого дуба Carbone, матовой лакированной отделки Castoro и компактной поверхности Milltek.











Sopra e a sinistra: colonne con struttura e vani a giorno in poro Rovere Carbone, ante in laccato Castoro opaco. A sinistra: basi in laccato Castoro opaco. | Above and left: columns with open shelving and frame in open pore Carbone oak, doors in Castoro matt lacquer. Left: bases in Castoro matt lacquer. | Ci-dessus et à gauche : colonnes à structure et niches ouvertes en Rovere Carbone à pores ouverts, portes en laqué Castoro mat. À gauche : bases laqué Castoro mat. | Oben und links: Säulen mit Korpus und türlosen Regalen aus offenporiger Steineiche im Farbton Carbone und Türflügeln mit Lackoberfläche im Farbton Castoro matt. Links: Unterbauten mit Lackoberfläche im Farbton Castoro matt. | Вверху и слева: вертикальные шкафчики со структурой и открытыми отсеками, структура из пористого дуба Carbone, створки из лакированного матового Castoro. Слева: Основания из лакированного матового материала Castoro.

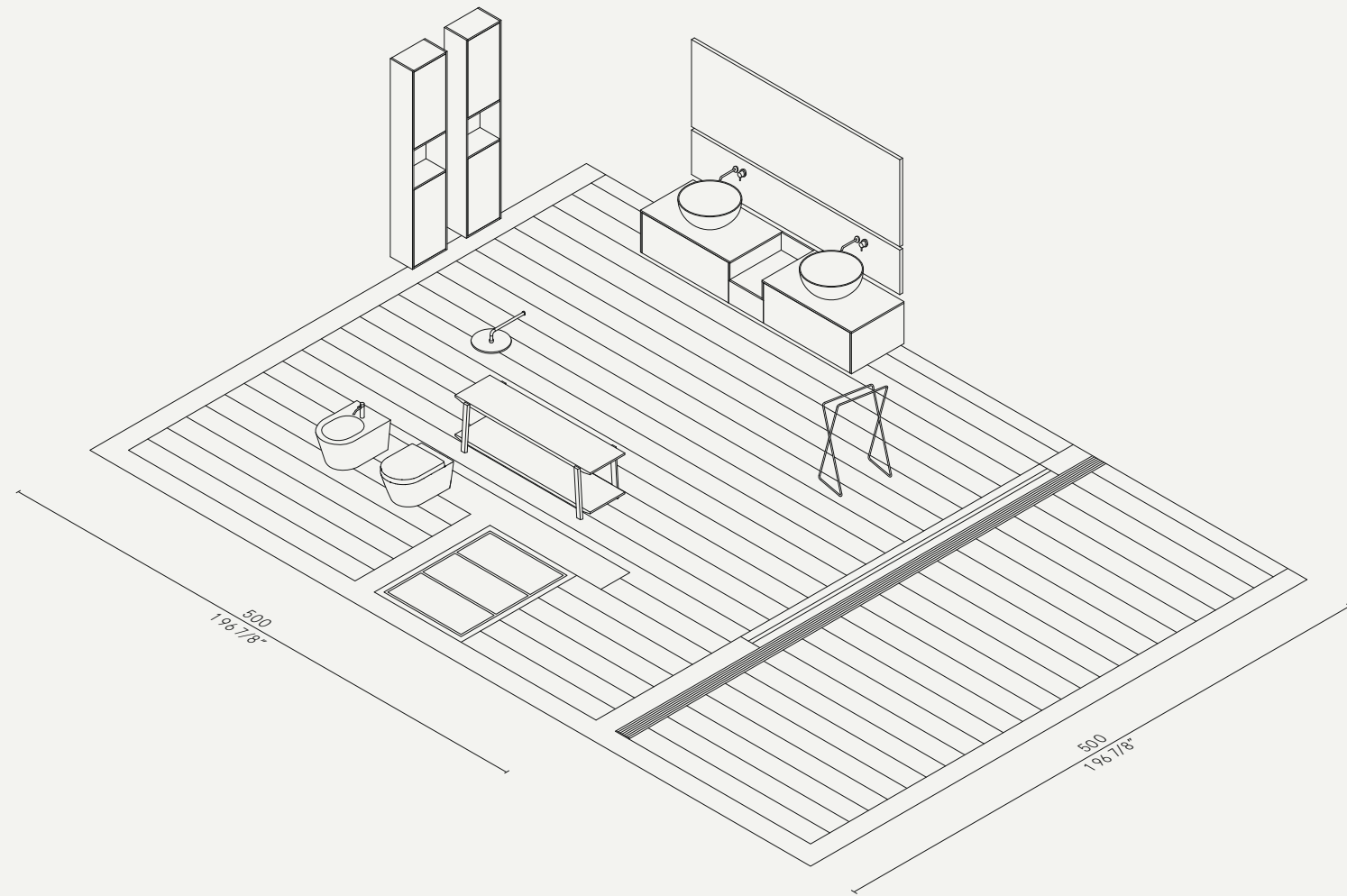

composizione | composition | Zusammensetzung | состав

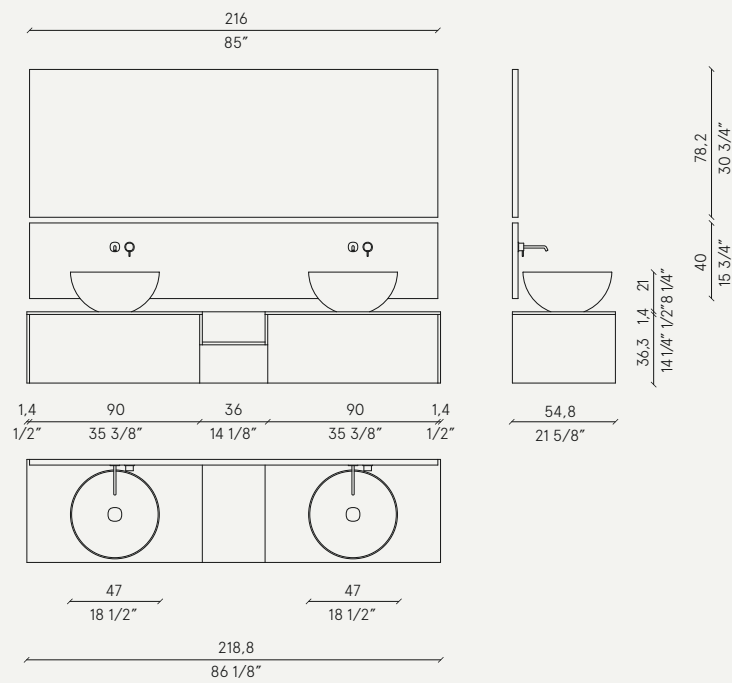

colonne | columns | colonnes | Säulen | столбы

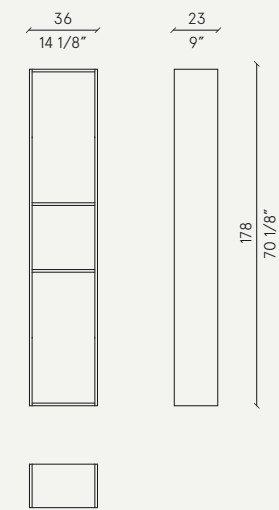

doccia Line | Line shower | douche Line | Duschteller Line | душа Line



portasciugamani | towel rack | porte-serviettes | Handtuchhalter | вешалка для полотенец

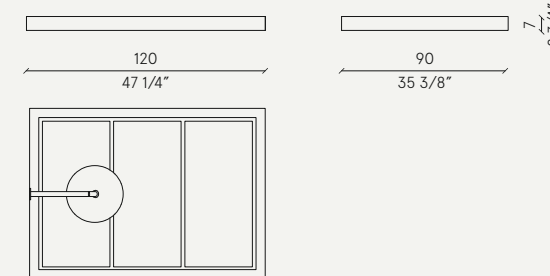
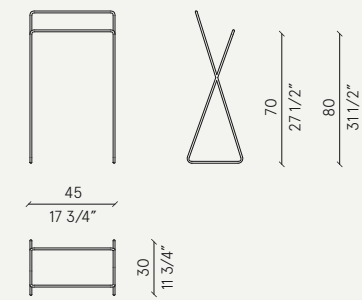

sanitari Senna | Senna sanitaryware | sanitaires Senna | Sanitäranlagen Senna | сантехника Senna

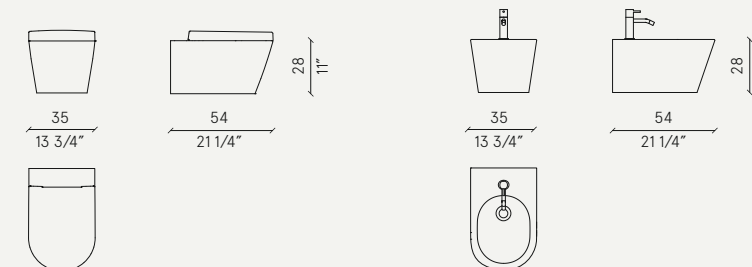

consolle | console | Konsole | Консоль

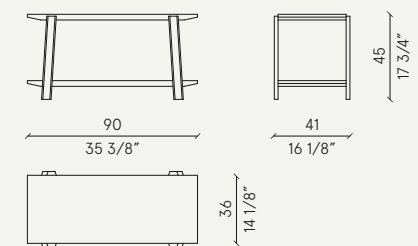

Lavabi in appoggio Blow 47 in Milltek. Basi con apertura push-pull, top e fianchi di finitura in laccato Castoro opaco con vano a giorno in poro Rovere Carbone. Specchiere sp.3 con retroilluminazione a led su quattro lati. Colonne con struttura e vani a giorno in poro Rovere Carbone, ante in laccato Castoro opaco. Consolle serie Bali. Piatto doccia Line in Milltek. Portasciugamani Darma. Sanitari Senna in ceramica opaca. Rubinetteria Flow in acciaio inox satinato. I Blow 47 countertop washbasin in Milltek. Bases with push-pull opening, top and sides in Castoro matt lacquer with open vanity in open pore Carbone oak. Four-sided LED-backlit th.3 mirrors. Columns with open shelving and frame in open pore Carbone oak, doors in matt Castoro lacquer. Bali console in open pore Carbone oak. Line shower tray in Milltek. Darma towel rack. Senna glossy ceramic sanitaryware. Flow taps in brushed stainless steel. I Lavabo à poser Blow 47 en Milltek. Bases à ouverture push-pull, plan et côtés de finition en laqué Castoro mat avec niche ouverte Rovere Carbone à pores ouverts. Miroirs ép.3 rétroéclairage led sur les quatre côtés. Colonnes à structure et niches ouvertes en chêne rouvre Carbone à pores ouverts, portes en laqué Castoro mat. Consoles série Bali en Rovere Carbone à pores ouverts. Bac à douche Line en Milltek. Porte-serviettes Darma. Sanitaires Senna en céramique mate. Robinetterie Flow en acier inox satiné. I Waschbecken aufliegend Blow 47 aus Milltek. Unterbauten mit Push&Pull Öffnungssystem, Einfassung und Seitenwände mit Lackoberfläche im Farbton Castoro matt mit türlosem Regal aus offenporiger Steineiche im Farbton Carbone. Wandspiegel Di.3 mit Led-Hintergrundbeleuchtung auf allen vier Seiten. Säulen mit Korpus und türlosen Regalen aus offenporiger Steineiche im Farbton Carbone und Türflügeln mit Lackoberfläche im Farbton Castoro matt. Konsole Serie Bali aus offenporiger Steineiche im Farbton Carbone. Duschteller Line aus Milltek. Handtuchhalter Darma. Sanitäranlagen Senna aus matter Keramik. Wasserhähne Flow aus satiniertem Edelstahl. I Раковины, установленные на столешницу Blow 47 из Milltek. Открывающиеся при нажатии основания, верх и боковины из лакированного матового Castoro с открытым отсеком из пористого дуба Carbone. Зеркала толщ.3 с подсветкой из светодиодов с четырех сторон. Вертикальные шкафчики со структурой и открытыми отсеками, структура из пористого дуба Carbone, створки из лакированного матового Castoro. Консоль серии Bali из пористого дуба Carbone. Поддон для душа Line из Milltek. Вешалка для полотенец Darma. Сантехника Senna из матовой керамики. Смесители Flow из сатирированной нержавеющей стали.

second chapter proposals



225 x 54,8 x 207 cm
88 5/8" x 21 5/8" x 81 1/2"

Rovere Termocotto
Milltek

Lavabo in appoggio Blend 81 in Milltek. Top in Rovere Termocotto con illuminazione a led inferiore. Basi, vano a giorno e fianchi di finitura in Rovere Termocotto. Specchiera sp. 5 con illuminazione a led centrale e profili a specchio. Rubinetteria Flow in acciaio inox satinato. | Blend 81 countertop washbasin in Milltek. Top in Termocotto oak with lower LED lighting. Bases, open vanity and side finishes in Termocotto oak. Th.5 mirror with central LED lighting and mirrored profiles. Flow taps in brushed stainless steel. | Lavabo à poser Blend 81 en Milltek. Plan en Rovere Termocotto éclairage led sur le bas. Bases, niches ouvertes et côtés de finition en Rovere Termocotto. Miroir ép. 5 éclairage led central et profils en miroir. Robinetterie Flow en acier inox satiné. | Waschbecken aufliegend Blend 81 aus Milltek. Einfassung aus Steineiche im Farbton Termocotto mit Led-Beleuchtung im unteren Bereich. Unterbauten, türlose Regale und Seitenwände mit Oberflächenausführung in Steineiche im Farbton Termocotto. Wandspiegel Di.5 mit zentraler Led-Spiegelbeleuchtung. Wasserhähne Flow aus satiniertem Edelstahl. | Раковина, установленная на столешницу Blend 81 из Milltek. Столешница из Дуба Termocotto с подсветкой от нижнего светодиода. Основания с открытыми отсеками, боковины с отделкой из Дуба Termocotto. Зеркало толщ. 5 с диодной подсветкой центральным светодиодом и зеркальными профилями. Смесители Flow из satinированной нержавеющей стали.







Sopra: top e vano a giorno in Rovere Termocotto con illuminazione a led. A destra: dettaglio lavabo Blend 81 in Milltek. | Above: top and open vanity Termocotto oak with LED lighting. Right: detail of Blend 81 washbasin in Milltek. | Ci-dessus : plan et niche ouverte en Rovere Termocotto éclairage led. À droite : détail lavabo Blend 81 en Milltek. | Oben: Einfassung und türloses Regal aus Steineiche im Farbton Termocotto mit Led-Beleuchtung. Rechts: Detail Waschbecken Blend 81 aus Milltek. | Вверху: столешница и открытый отсек из дуба Termocotto с подсветкой светодиодами. Справа: детали раковины Blend 81 из Milltek.

poro Rovere Carbone 180 x 46 x 190 cm
 Milltek 70 7/8" x 18 1/8" x 74 3/4"

Base con gola superiore frontale e laterale in poro Rovere Carbone con lavabo Man 144 in Milltek. Specchiera girevole con specchio ingranditore. Rubinetteria Flow in acciaio inox satinato. | Base with upper front and side groove in open pore Carbone oak and Man 144 washbasin in Milltek. Magnifying swivel mirror. Flow taps brushed stainless steel. | Base à gorge supérieure frontale et latérale en Rovere Carbone à pores ouverts avec lavabo Man 144 en Milltek. Miroir pivotant doté d'un miroir grossissant. Robinetterie Flow en acier inox satiné. | Unterbau mit im oberen Bereich stirnseitig und seitlich angebrachter Aussparung, aus offenporiger Steineiche im Farbton Carbone, mit Waschbecken Man 144 aus Milltek. Drehbarer Wandspiegel mit Vergrößerungsspiegel. Wasserhähne Flow aus satiniertem Edelstahl. | Основание с верхним передним и боковым углублением из пористого Дуба Carbone с раковиной Man 144 из Milltek. Поворачивающееся зеркало с увеличительной линзой. Смесители Flow из сатинированной нержавеющей стали.



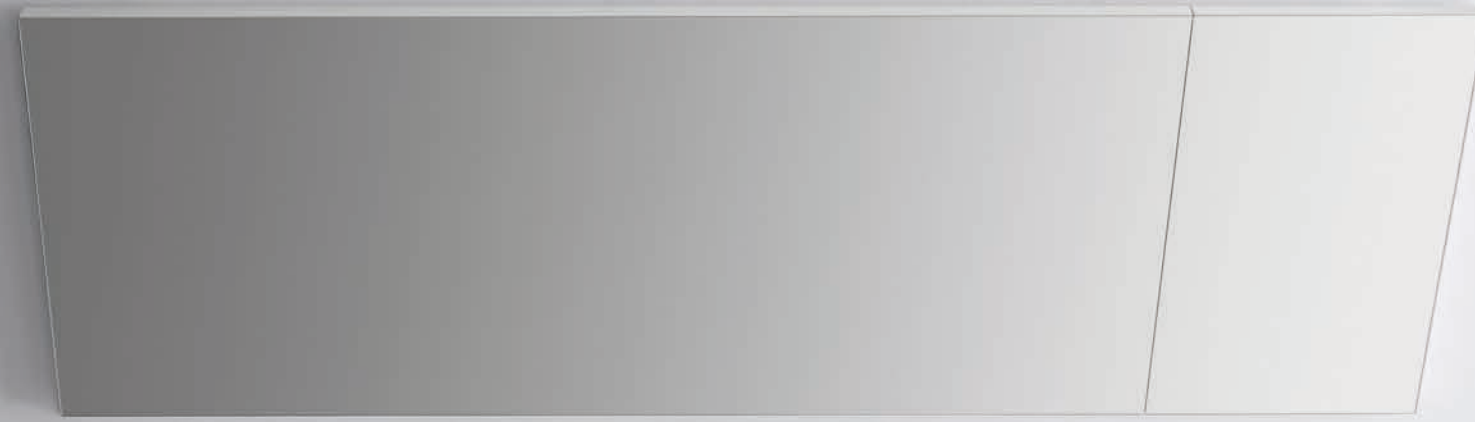



A sinistra: lavabo Man 144 in Milltek con dettaglio spessore bordo 6 mm. Sopra: dettaglio base con gola superiore frontale e laterale con taglio a 45° in poro Rovere Carbone. | Left: Man 144 washbasin in Milltek with detail of 6mm edge thickness. Above: detail of base with upper front and side groove with 45° cutting angle in open pore Carbone oak. | À gauche : lavabo Man 144 en Milltek avec détail épaisseur bord 6 mm. Ci-dessus : détail base à gorge frontale et latérale supérieur et découpe à 45° en Rovere Carbone à pores ouverts. | Links: Waschbecken Man 144 aus Milltek mit Detail, Dicke Rand 6 mm. Oben: Detail Unterbau mit stirnseitig und seitlich angebrachter Aussparung mit 45° Gehrungsschnitt, aus offenporiger Steineiche im Farbton Carbone. Слева: раковина Man 144 из Milltek с деталью борта толщиной 6 мм. Вверху: детали основания верхнего переднего и бокового углубления со срезом под 45° из пористого Дуба Carbone.

laccato Origano opaco 216 x 46 x 215,5 cm
 laminato Venato Biscotto 85" x 18 1/8" x 84 7/8"
 Milltek

Base con gola centrale in laccato Origano opaco con lavabo Man 126 in Milltek. Specchiera sp. 3 con retroilluminazione led inferiore e superiore. Pensili con struttura e vano a giorno in laminato Venato Biscotto e anta in laccato Origano opaco. Rubinetteria Flow in acciaio inox satinato. | Base with central groove in Origano matt lacquer with Man 126 washbasin in Milltek. Upper and lower LED-backlit th. 3 mirror. Wall units with frame and open shelving in Venato Biscotto laminate and door in Origano matt lacquer. Flow taps in brushed stainless steel. | Base à gorge centrale en laqué Origano mat et lavabo Man 126 en Milltek. Miroir ép. 3 à éclairage led inférieur et supérieur. Meubles muraux à structure et niche ouverte en mélaminé Venato Biscotto et porte en laqué Origano mat. Robinetterie Flow en acier inox satiné. | Unterbau mit zentral angebrachter Aussparung mit Lackoberfläche im Farbton Origano matt mit Waschbecken Man 126 aus Milltek. Wandspiegel Di.3 mit Led-Beleuchtung im unteren und oberen Bereich. Hängeschrank mit Korpus und türloses Regal aus Venato-Laminat im Farbton Biscotto und Türflügel mit Lackoberfläche im Farbton Origano matt. Wasserhähne Flow aus satiniertem Edelstahl. | Основание с центральным углублением из лакированного матового Origano с раковиной Man 126 из Milltek. Зеркало толщ. 3 с нижней и верхней подсветкой от светодиодов. Полки со структурой и открытым отсеком из ламината Venato Biscotto и створка из лакированного матового Origano. Смесители Flow из сатинированной нержавеющей стали.



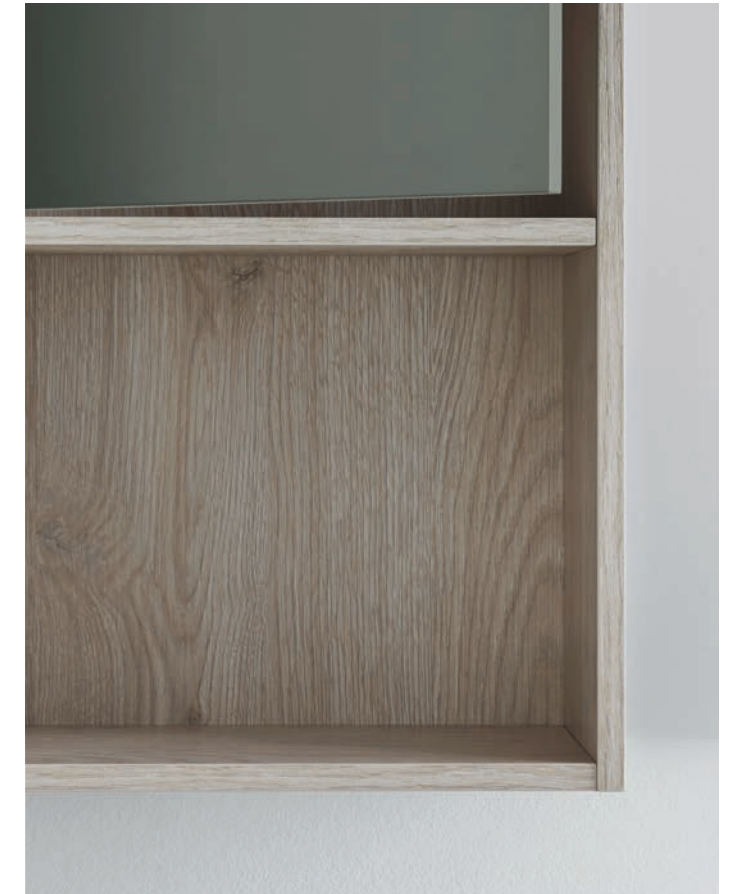
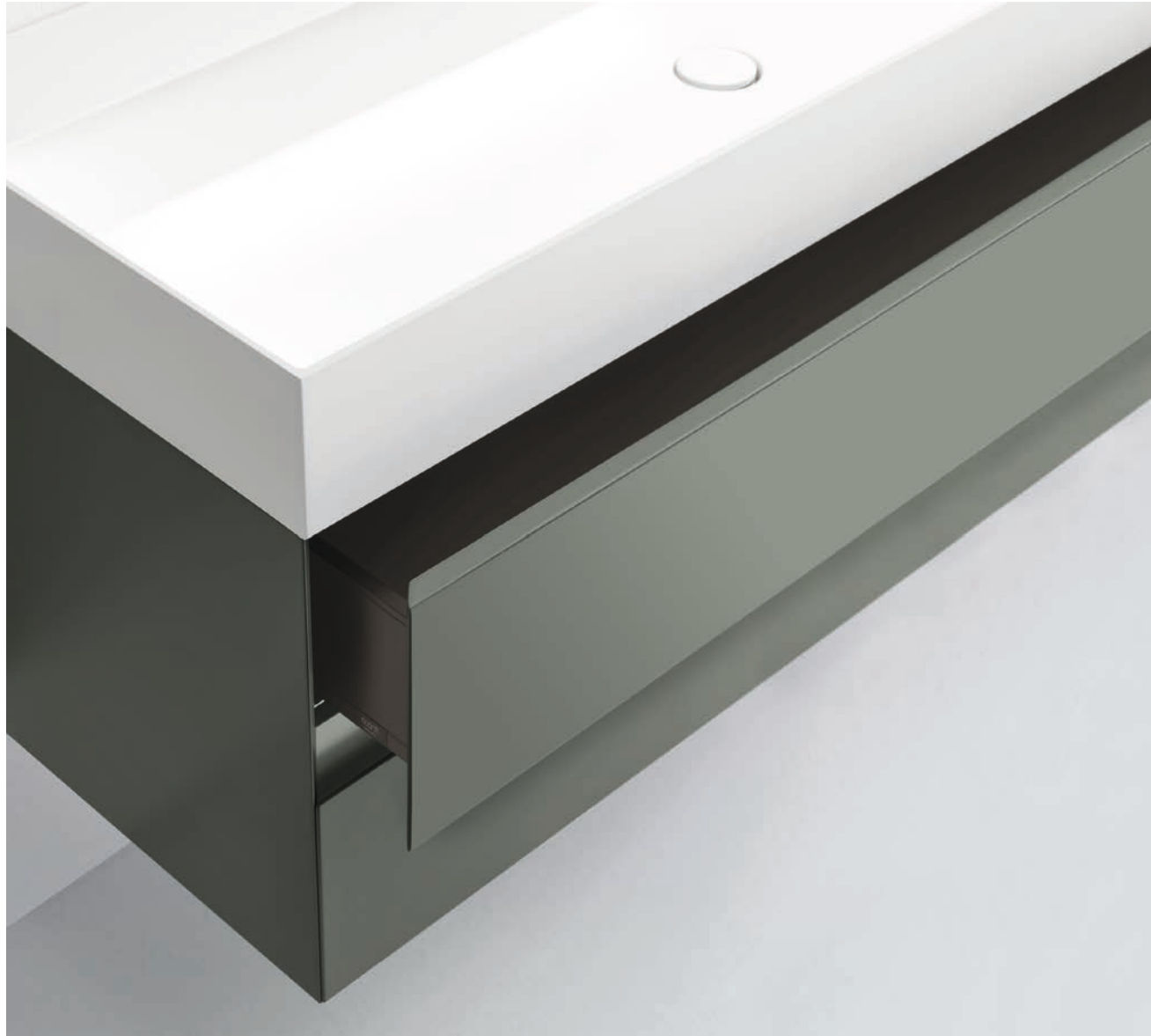

A sinistra: dettaglio frontale e fianco a 45° in laccato Origano opaco. Sopra: dettaglio vano a giorno in laminato Venato Biscotto.
Left: details of 45° of front and sides in Origano matt lacquer. Above: detail of open shelving in Venato Biscotto laminate. | À gauche : détail base découpe à 45° et côtés en laqué Origano mat. Ci-dessus : détail niche ouverte en mélaminé Venato Biscotto. | Links: Detail Unterbau mit 45° Gehrungsschnitt und Seitenwände mit Lackoberfläche im Farbton Origano matt. Oben: Detail türloses Regal aus Venato-Laminat im Farbton Biscotto. | Слева: детали основания со срезом под 45° и боковины из лакированного матового Origano. Вверху: деталь открытого отсека из ламината Venato Biscotto.

180 x 46 x 190,2 cm
70 7/8" x 18 1/8" x 74 7/8"

laminato Ares Fango
Milltek

Lavabo sospeso Man 90 in Milltek. Base con maniglia M051 in laccato Fango opaco e top in laminato Ares Fango. Portasciugamano in Milltek. Specchiera sp.3 con retroilluminazione a led superiore. Mensola in laccato Bianco opaco. Rubinetteria Flow in acciaio inox satinato. | Man 90 wall-mounted washbasin in Milltek. Base with M051 handle in Fango matt lacquer and top in Ares Fango laminate. Towel rack in Milltek. th. 3 mirror with upper LED-backlit. Shelf in Bianco matt lacquer. Flow taps in brushed stainless steel. | Lavabo suspendu Man 90 en Milltek. Base à poignée M051 en laqué Fango mat et plan en mélaminé Ares Fango. Porte-serviettes en Milltek. Miroir ép.3 rétroéclairage led sur le haut. Étagère en laqué Bianco mat. Robinetterie Flow en acier inox satiné. Hängendes Waschbecken Man 90 aus Milltek. Unterbau mit Türgriff M051 mit Lackoberfläche im Farbton Fango matt und Einfassung aus Ares-Laminat im Farbton Fango. Handtuchhalter aus Milltek. Wandspiegel Di. 3 mit Led-Hintergrund-beleuchtung im oberen Bereich. Ablagefläche mit Lackoberfläche im Farbton Bianco matt. Wasserhähne Flow aus satiniertem Edelstahl. Подвесная раковина Man 90 из Milltek. Лакированное основание с ручкой Fango и столешница из ламината из Ares Fango. Вешалка для полотенец из Milltek. Зеркало толщ.3 с подсветкой верхним светодиодом. Полка из лакированного матового материала Bianco. Смесители Flow из сатинированной нержавеющей стали.





Sopra e a sinistra: base con maniglia M051 in laccato Fango opaco e top in laminato Ares Fango. A sinistra: lavabo sospeso Man 90 in Milltek. Mensola in laccato Bianco opaco. Rubinetteria Flow in acciaio inox satinato. | Above and left: base with M051 handle in Fango matt lacquer and top in Ares Fango laminate. Left: Man 90 wall-mounted washbasin in Milltek. Shelf in Bianco matt lacquer. Flow taps in brushed stainless steel. | Ci-dessus et à gauche : base à poignée M051 en laqué Fango mat et plan en mélaminé Ares Fango. À gauche : lavabo suspendu Man 90 en Milltek. Étagère en laqué Bianco mat. Robinetterie Flow en acier inox satiné. | Oben und links: Unterbau mit Türgriff M051 mit Lackoberfläche im Farbton Fango matt und Einfassung aus Ares-Laminat im Farbton Fango. Links: Hängendes Waschbecken Man 90 aus Milltek. Ablagefläche mit Lackoberfläche im Farbton Bianco matt. Wasserhähne Flow aus satiniertem Edelstahl. | Вверху и слева: лакированное основание с ручкой Fango и столешница из ламината из Ares Fango. Слева: подвесная раковина Man 90 из Milltek. Полка из лакированного матового материала Bianco. Смесители Flow из сатирированной нержавеющей стали.

216 x 47,3 x 198,2 cm
85" x 18 5/8" x 78"

Argilla polvere

Top sospeso integrato Land 01 in Argilla Polvere. Basi con gola superiore frontale e laterale e top in Argilla Polvere. Specchiera sp.3 con retroilluminazione a led su quattro lati. Rubinetteria Flow in acciaio inox satinato. | Land 01 wall-mounted integrated top with double washbasins in Polvere clay. Bases with upper, front and side groove and top in Polvere clay. Four-sided LED-backlit Th.3 mirror. Flow taps in brushed stainless steel. | Plan suspendu intégré Land 01 en argile Polvere. Bases à gorge frontale et latérale sur le haut et plan en argile Polvere. Miroir ép.3 rétroéclairage led sur les quatre côtés. Robinetterie Flow en acier inox satiné. Integrierte hängende Einfassung Land 01 aus Lehm im Farbton Polvere. Unterbauten mit stirnseitiger und seitlicher Aussparung, Einfassung aus Lehm im Farbton Polvere. Wandspiegel Di. 3 mit Led-Hintergrundbeleuchtung auf allen vier Seiten. Wasserhähne Flow aus satiniertem Edelstahl. | Интегрированная подвесная столешница Land 01 из Глины Polvere. Основания с верхним передним и боковым углублением, столешница из Глины Polvere. Зеркало толщ.3 с подсветкой из светодиодов с четырех сторон. Смесители Flow из сатинированной нержавеющей стали.





A sinistra: top sospeso integrato Land 01 in Argilla Polvere. Sopra: dettaglio gola superiore frontale e laterale in laccato anodizzato Champagne. | Left: Land 01 wall-mounted integrated top in Polvere clay. Above: detail of upper front and side groove in Champagne-colored painted anodised. | A gauche : plan suspendu intégré Land 01 en argile Polvere. Ci-dessus : détail gorge frontale et latérale supérieur en laqué anodisé Champagne. | Links: integrierte hängende Einfassung Land 01 aus Lehm im Farbton Polvere. Oben: Detail stirnseitige und seitliche Aussparung im oberen Bereich aus eloxiertem lackiert Champagne. Слева: интегрированная подвесная столешница Land 01 из Глины Polvere. Вверху: деталь верхнего переднего и бокового углубления из лакировка анодирование Champagne.

162 x 56 x 210 cm
63 3/4" x 22" x 82 5/8"

marmo Arabescato

Base predisposta per scarico a pavimento con lavabo Full 100 in marmo Bianco Arabescato. Specchiera inclinata con retroilluminazione a led e profilo a specchio. Rubinetteria Flow in acciaio inox satinato. | Base suitable for floor drain with Full 100 washbasin in Bianco Arabescato marble. Tilted LED-backlit mirror with mirror profile. Flow taps in brushed stainless steel. | Base prédisposée pour évacuation au sol avec lavabo Full 100 en marbre Bianco Arabescato. Miroir incliné rétroéclairage led et profil en miroir. Robinetterie Flow en acier inox satiné. | Für Bodenablauf vorgerüsteter Unterbau mit Waschbecken Full 100 aus Arabescato-Marmor im Farbton Bianco. Schräger Wandspiegel mit Led-Hintergrundspiegelbeleuchtung und Spiegelprofil. Wasserhähne Flow aus satiniertem Edelstahl. | Основание со сливом в пол с раковиной Full 100, из мрамора Bianco Arabescato. Наклонное зеркало с диодной подсветкой и зеркальным профилем. Смесители Flow из сатинированной нержавеющей стали.



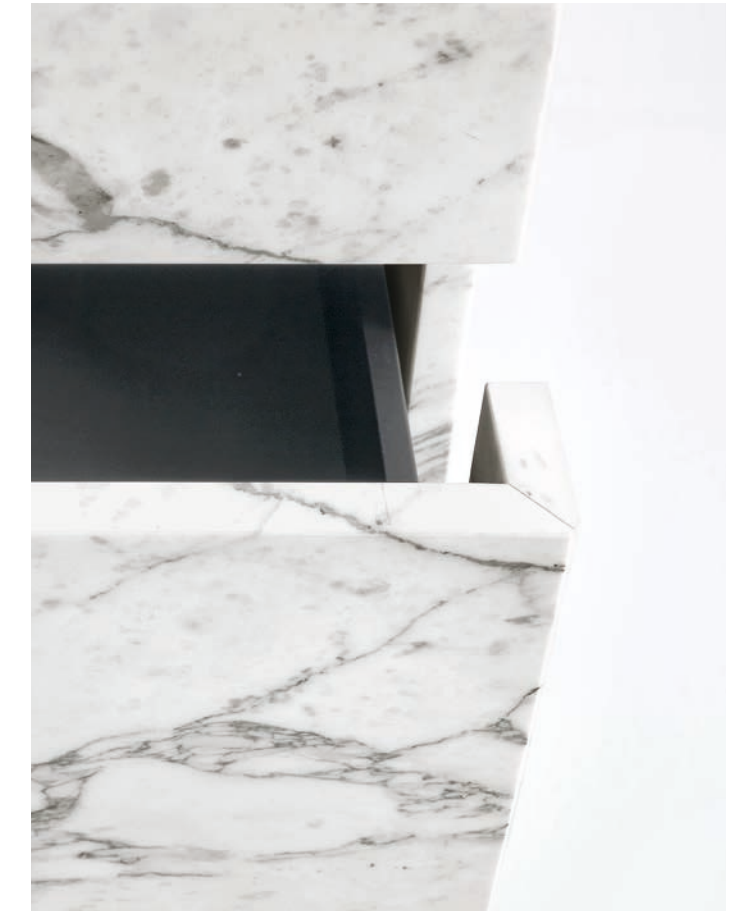

Sopra: dettaglio cassetto con apertura push-pull. A sinistra: base predisposta per scarico a pavimento con lavabo Full 100 in marmo Bianco Arabescato. Rubinetteria Flow in acciaio inox satinato. | Above: detail of push-pull opening drawer. Left: base suitable for floor drain with Full 100 washbasin in Bianco Arabescato marble. Flow taps in brushed stainless steel. | Ci-dessus : détail tiroir à ouverture push-pull. À gauche : base prédisposée pour évacuation au sol avec lavabo Full 100 en marbre Bianco Arabescato. Robinetterie Flow en acier inox satiné. | Oben: Detail Schubfach mit Push&Pull Öffnungssystem. Links: Für Bodenablauf vorgerüsteter Unterbau mit Waschbecken Full 100 aus Arabescato-Marmor im Farbton Bianco. Wasserhähne Flow aus satiniertem Edelstahl. Вверху: деталь ящика с открытием с нажатием. Слева: основание со сливом в пол с раковиной Full 100, из мрамора Bianco Arabescato. Смесители Flow из сатинированной нержавеющей стали.

third chapter elements



COLLECTION

Proposte diverse per interpretare al meglio l'identità di ogni progetto, linguaggi differenti che si incontrano attorno a temi condivisi, elementi che diventano protagonisti dello spazio e ne definiscono le funzioni. La proposta Noorth è un percorso all'insegna dell'eccellenza, della qualità dei materiali, delle forme essenziali ed eleganti, di un linguaggio contemporaneo ottenuto dalla perfetta sintesi di tutti i suoi componenti. Collezioni in grado di inserirsi al meglio in ambienti molto piccoli o al contrario di esprimersi compiutamente in ambienti bagno più ampi. Proposte nelle quali la tecnologia viene celata dalle soluzioni più raffinate, la capacità artigianale di lavorare i materiali estrapolandone l'essenza viene valorizzata da soluzioni sartoriali, cucite sulle esigenze personali. In questa sezione viene presentata una panoramica completa, dai lavabi ai top integrati e sospesi, dai piatti doccia alle vasche fino ad arrivare alla rubinetteria. Un abaco che esplora un paesaggio di componenti e accessori coordinato, trasversale a tutti i sistemi di contenimento. Uno strumento di consultazione pratico e immediato, un supporto alla progettazione completo di note, dati tecnici e approfondimenti puntuali per conoscere una realtà unica, che associa stile e tecnologia, flessibilità e personalizzazione.

A wide range of proposals to better interpret each project's identity, different languages convening on shared themes, furnishing elements rising to the status of key players in decorating the interiors and defining its functions. Furnishing proposals by Noorth are at the forefront of excellence, drawing upon quality of materials, simple yet elegant forms, as well as speaking a contemporary language shaped by the perfect synthesis of all its components. Such collections are only too capable of blending into very cozy interiors or, conversely, of expressing themselves to the fullest in more spacious bathroom environments. Such furnishing proposals tend to downplay their technology content in their most sophisticated solutions, as the craftsmanship that goes into working precious materials by extracting their true essence is enhanced through tailored solutions, made to meet individual needs. This section provides a complete overview, from washbasins to wall-mounted and integrated tops, and from shower trays to bathtubs and faucets. In other words, an abacus that explores a wealth of components and matching accessories, running through the whole range of storage systems. A handy and intuitive consultation tool, a project design assistant complete with footnotes, technical data and accurate insights to come to grips with a unique furnishing manufacturer, which combines style and technology, flexibility and customization.

Noorth propose des solutions différentes pour interpréter au mieux l'identité de chaque projet, des langages distincts qui se rencontrent autour de thèmes partagés, des éléments qui deviennent les vedettes de l'espace et en définissent les fonctions. Notre offre est un parcours sous le signe de l'excellence, de la qualité des matières, des formes essentielles et élégantes, d'un langage contemporain fruit de la synthèse parfaite de tous ses composants. Nos collections parviennent aussi bien à trouver leur place dans de très petits espaces qu'à s'exprimer pleinement dans des salles de bain de plus grandes dimensions. Dans nos produits, les solutions les plus raffinées dissimulent la technologie tandis que le travail artisanal des matériaux en vue d'en extraire leur essence est valorisé par des projets sur mesure, spécialement élaborés selon les exigences de chacun. Cette section présente un aperçu complet de nos produits, des lavabos aux plans intégrés et suspendus en passant par les bacs à douches et les baignoires sans oublier la robinetterie. Un éventail qui explore un univers de composants et d'accessoires assortis convenant à tous les systèmes de rangement. Grâce à ses notes, ses données techniques et ses approfondissements précis qui permettent de mieux connaître nos produits - véritable condensé de style, de technologie, de flexibilité et de personnalisation - cet outil de consultation pratique et immédiat constitue une aide incontournable pour tous les projets.

ELEMENTS

Verschiedene Lösungen, die die Wesensart jedes Projekts auf bestmögliche Weise zu deuten verstehen. Unterschiedliche Ausdrucksformen, die zur Umsetzung eines Konzepts zusammentreffen, Elemente, die zu Hauptakteuren der Raumgestaltung werden und die Funktionen bestimmen: Noorth präsentiert Möglichkeiten der Badezimmergestaltung, bei denen die Qualitäten der Materialien und sich aufs Wesentliche beschränkende, edle Formen im Mittelpunkt stehen, und in all ihren Bestandteilen eine dem Zeitgeist der Gegenwart perfekt angepasste Sprache sprechen. Es handelt sich um Kollektionen, die sich auf bestmögliche Weise sowohl in sehr kleine Räume integrieren lassen, als auch in großen Badezimmern ihre volle Ausdruckskraft entfalten. Die Gestaltungsideen verbergen unter ihrem erlesenen Erscheinungsbild hochstehende Technologien. Durch ihre, den persönlichen Ansprüchen des Nutzers Rechnung tragenden, maßgefertigten und die Besonderheit der Materialien hervorhebenden Verarbeitungen machen sie gleichzeitig auf das handwerkliche Können sichtbar. In diesem Kapitel wird ein komplette Übersicht aller Bestandteile der Badezimmereinrichtung vorgestellt: von Waschbecken, bis zu integrierten und hängenden Einfassungen, von Duschtellern bis zu Badewannen und Wasserhähnen. Es lädt zu Erkundungen in einer Landschaft von unzähligen, aufeinander abgestimmten Elementen, Zubehörteilen und Behältnissystemen ein und stellt ein praktisches, Stil und Technologie, Flexibilität und persönliche Bedürfnisse vereinbarendes Nachschlagewerk und dank seiner Vollständigkeit und den darin enthaltenen Anmerkungen und technischen Daten auch eine wertvolle Hilfe für die Planung dar.

Различные предложения позволяют лучше интерпретировать индивидуальность каждого проекта. Разные стили, объединенные общими темами, элементы, которые становятся главными действующими лицами жилого пространства и определяют его функции. Мебель Noorth - это путь к совершенству, качеству материалов, простых и элегантных форм, современному стилю, достигаемому благодаря безупречному синтезу всех его составляющих. Коллекции, способные вписываться в очень маленькие помещения, или, наоборот, проявить себя в полной мере в больших ванных комнатах. Наши предложения, скрывающие технологию посредством элегантных решений, ремесленное мастерство обработки материалов, позволяющее выявить их сущность, дополнительно усиленное благодаря индивидуальным решениям, подогнанным согласно конкретным потребностям заказчика. В этом разделе представлен полный обзор, от раковин до интегрированных и подвесных столешниц, от душевых поддонов до ванн и кранов. Различные элементы и координированные аксессуары, составляющие общую картину, применяемые во всех системах. Это практичный и быстрый инструмент для консультаций, помогающий при проектировании, дополненный примечаниями, техническими данными и точной детальной информацией, позволяющей ознакомиться с предлагаемыми решениями, сочетающимися в себе стиль и технологии, гибкость и индивидуальность оформления.

Un'ampia gamma di modelli che hanno nel rigore geometrico e nell'essenzialità il loro filo conduttore. Proposte contemporanee, come i lavabi da appoggio caratterizzati da bordi sottili che trasmettono un'immagine di leggerezza sofisticata. Tra le altre tipologie di installazione la gamma propone i lavabi incassati o sopra piano, che ripropongono forme classiche o esplorano configurazioni inedite interpretandole attraverso un'ampia offerta di materiali, da quelli più naturali come i marmi e le ceramiche a quelli sintetici e di nuova concezione.

A wide range of models whose common thread is to be found in their geometric rigor and essential style. These are furnishing proposals for contemporary living, such as the slender-edged countertop washbasins that convey an image of sophisticated elegance. Among other installation types, the range offers built-in or sit-on washbasins that reproduce classical forms or explore unusual configurations interpreting them through a wide range of sources, from the most natural like marble and ceramic varieties to the most advanced, man-made materials.

Cette riche gamme de modèles a pour fil conducteur le minimalisme et la rigueur géométrique. Elle se distingue par ses produits contemporains, notamment ses lavabos à poser aux bords fins qui en plus de conférer une touche de légèreté et d'élégance. Dans les autres types d'installation disponibles, la gamme comprend également des lavabos encastrables ou à poser repropoant des formes classiques ou explorant des configurations inédites à travers une vaste palette de matériaux allant des matières naturelles - comme les marbres ou les céramiques - aux matières synthétiques de nouvelle génération.

Eine breitgefächerte Auswahl an Modellen, durch die sich als roter Faden eine strenge geometrische Linienführung und ein sich aufs Wesentliche beschränkendes, schnörkelloses Erscheinungsbild ziehen. Es sind zeitgenössische Lösungen, die in Form von aufliegenden Waschbecken mit dünnem Beckenabschluss nicht nur das Bild von eleganter Leichtigkeit vermitteln. Die Montage sieht unter anderem integrierte Waschbecken, aber auch aufliegende Waschbecken vor, die einerseits klassische Formen wieder aufnehmen, andererseits mit Hilfe einer Vielzahl von Materialien, so zum Beispiel Marmor und Keramik, aber auch synthetischen Materialien neuester Machart, mit neuen Gestaltungs- und Anordnungsmöglichkeiten experimentieren.

Обширный диапазон моделей, отличающихся общей геометрической строгостью и простотой. Современные модели устанавливаемых на поверхность раковин с тонкими краями, создающих ощущение утонченной легкости и дополнительно увеличивающих объем. Гамма изделий включает встроенные или установленные на поверхность раковины, воспроизводящие классические формы или создающие новые необычные конфигурации, используя широкий спектр материалов, от самых натуральных, таких как мрамор и керамика, до синтетических и новых материалов.



Man 63

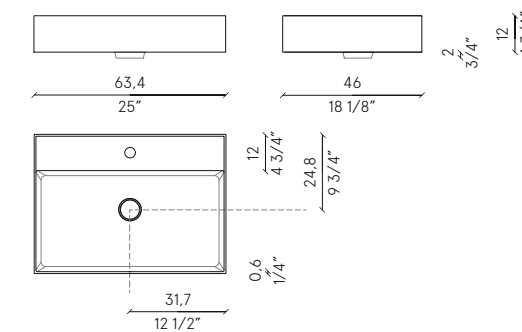

disposizione | layout | disposition | Anordnung | расположение

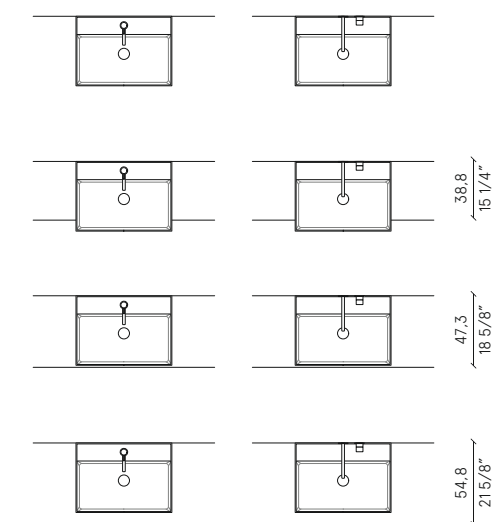

finiture | finishes | finitions | Oberflächen | отделки
 sintetici | compounds | synthétiques | Kunststoff | соединений

milltek

MAN 90

SIT ON



MAN 108

SIT ON



Man 90

disposizione | layout | disposition | Anordnung | расположение

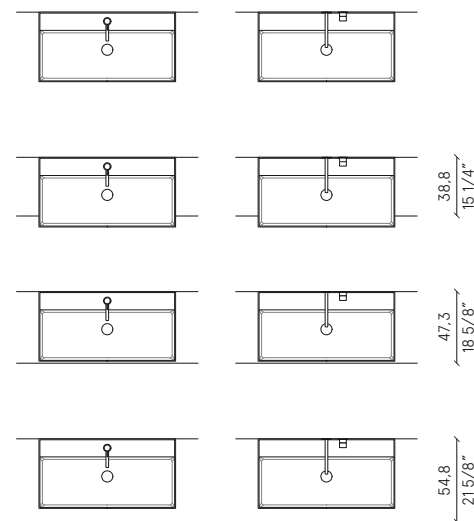
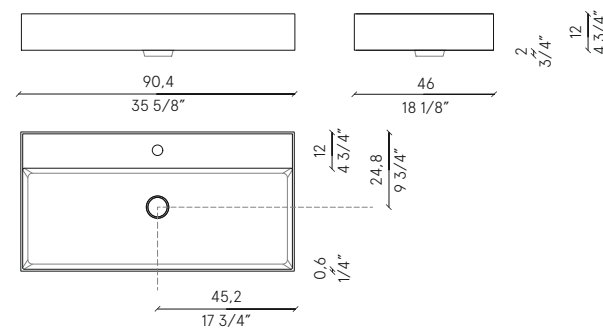

finiture | finishes | finitions | Oberflächen | отделки
 sintetici | compounds | synthétiques | Kunststoff | соединений

milltek

Man 108

disposizione | layout | disposition | Anordnung | расположение

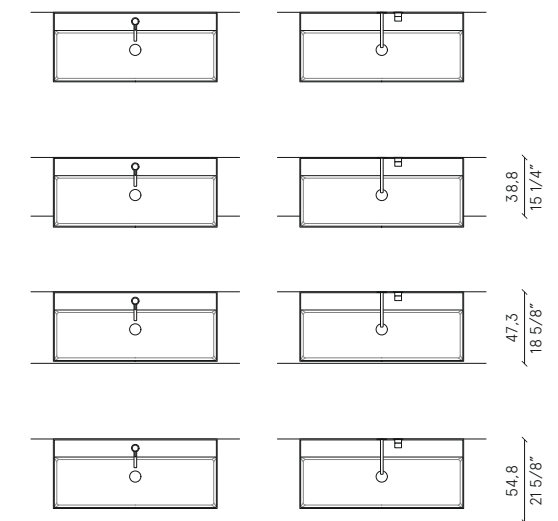
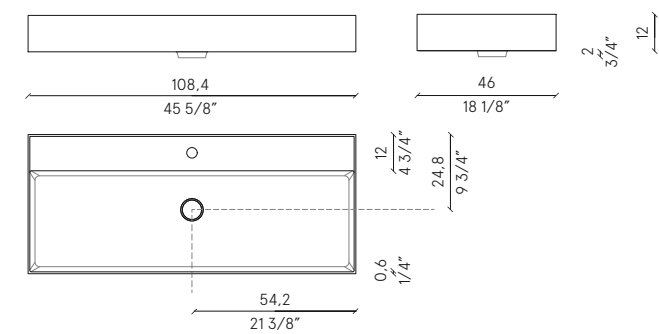

finiture | finishes | finitions | Oberflächen | отделки
 sintetici | compounds | synthétiques | Kunststoff | соединений

milltek

MAN 126

SIT ON



Man 126

disposizione | layout | disposition | Anordnung | расположение

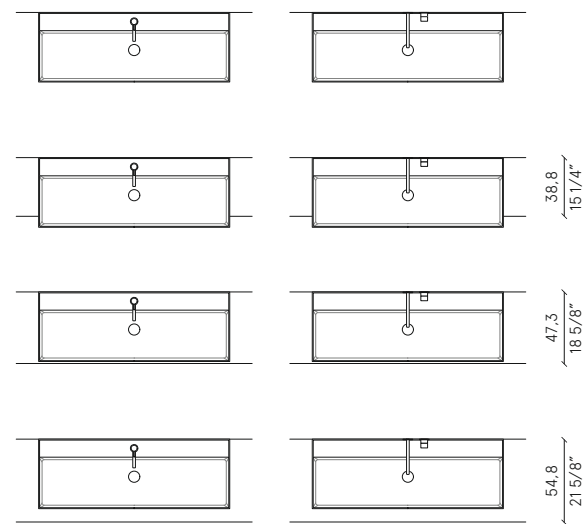
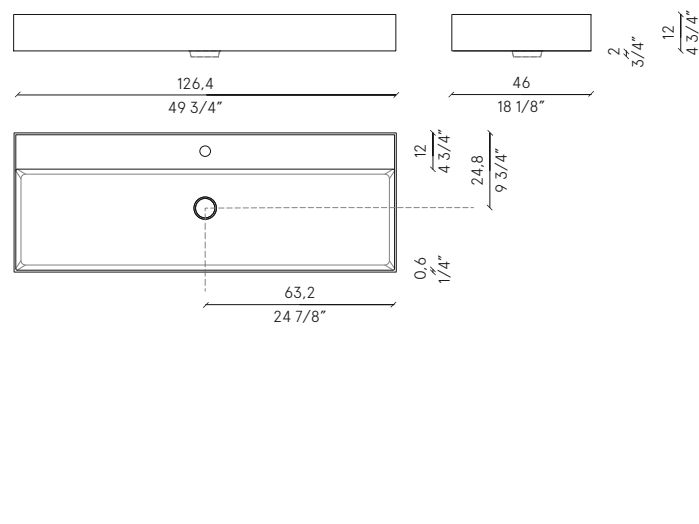

finiture | finishes | finitions | Oberflächen | отделки
 sintetici | compounds | synthétiques | Kunststoff | соединений

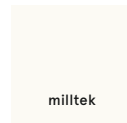

MAN 144

SIT ON



Man 144

disposizione | layout | disposition | Anordnung | расположение

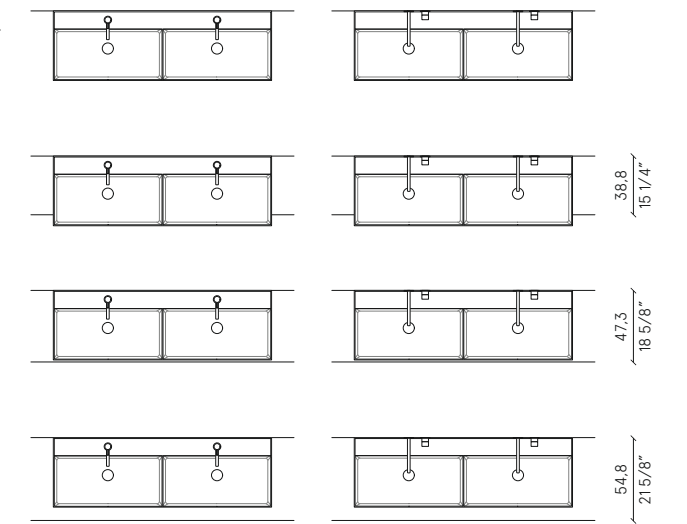
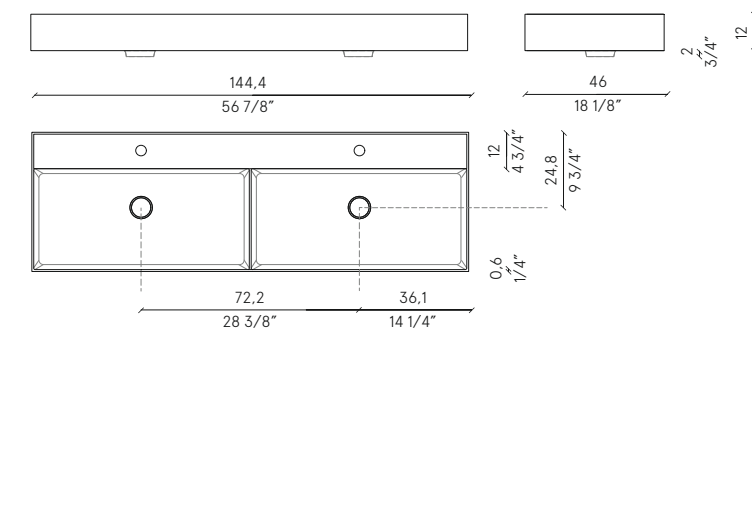

finiture | finishes | finitions | Oberflächen | отделки
 sintetici | compounds | synthétiques | Kunststoff | соединений

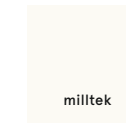

BLEND 63

SIT ON



Blend 63

disposizione | layout | disposition | Anordnung | расположение

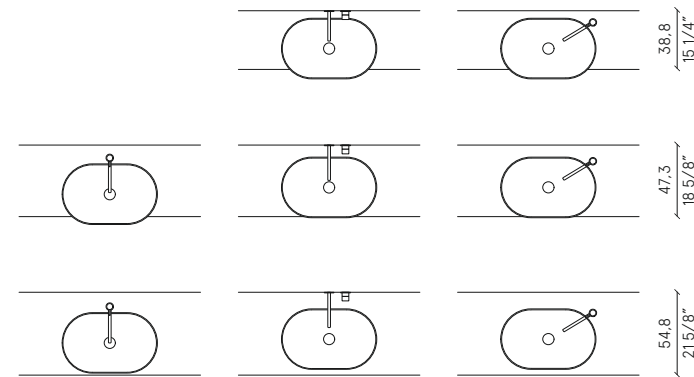
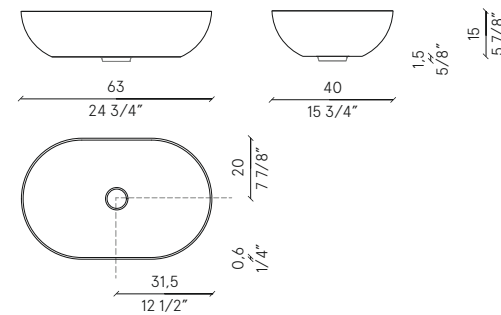

finiture | finishes | finitions | Oberflächen | отделки
 sintetici | compounds | synthétiques | Kunststoff | соединений

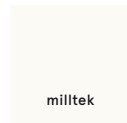

BLEND 81

SIT ON



Blend 81

disposizione | layout | disposition | Anordnung | расположение

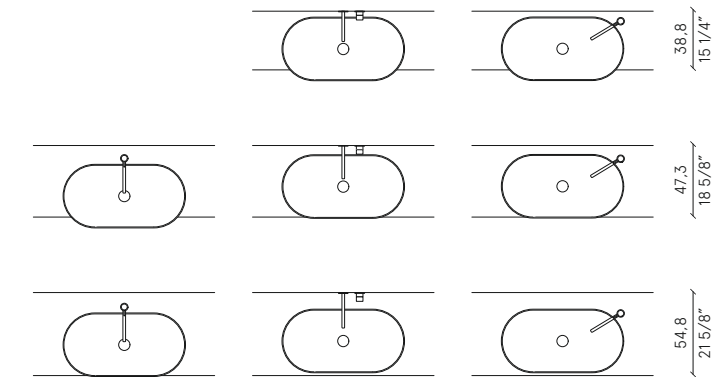
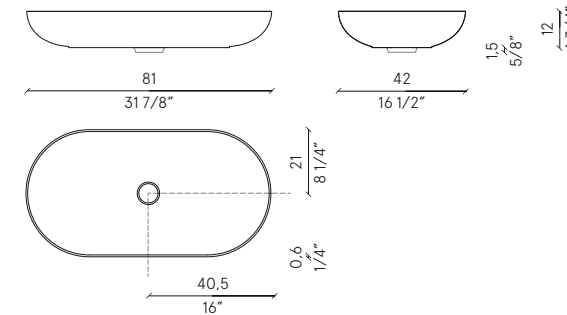

finiture | finishes | finitions | Oberflächen | отделки
 sintetici | compounds | synthétiques | Kunststoff | соединений

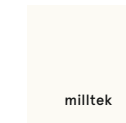

BOWL 47

SIT ON



KEEL 45

SIT ON



Bowl 47

disposizione | layout | disposition | Anordnung | расположение

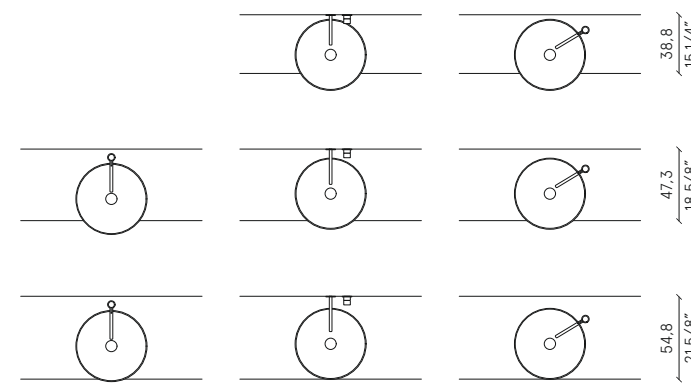
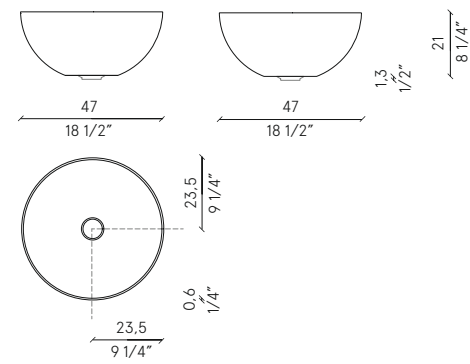

finiture | finishes | finitions | Oberflächen | отделки
 sintetici | compounds | synthétiques | Kunststoff | соединений

milltek

Keel 45

disposizione | layout | disposition | Anordnung | расположение

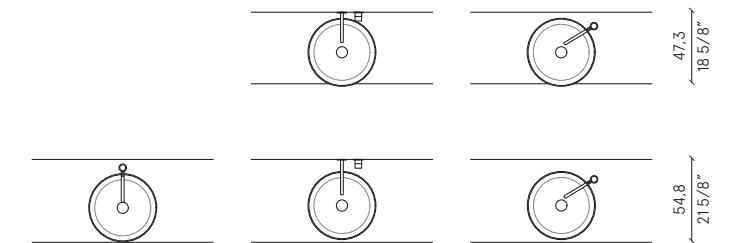
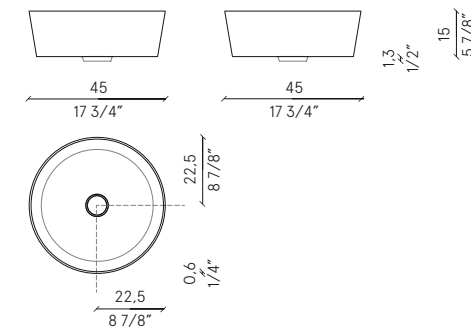

finiture | finishes | finitions | Oberflächen | отделки
 sintetici | compounds | synthétiques | Kunststoff | соединений

milltek

STEP 45.19

SIT ON



Step 45.19

disposizione | layout | disposition | Anordnung | расположение

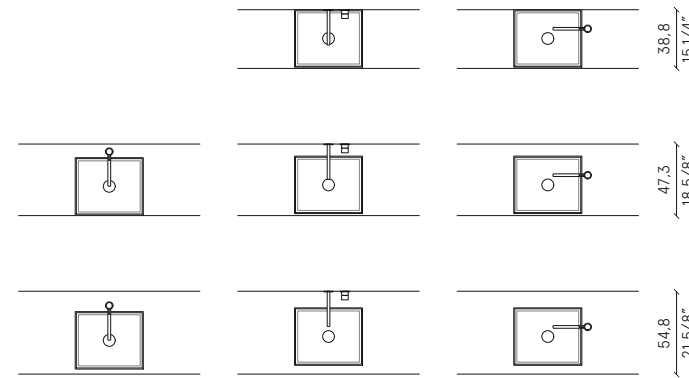
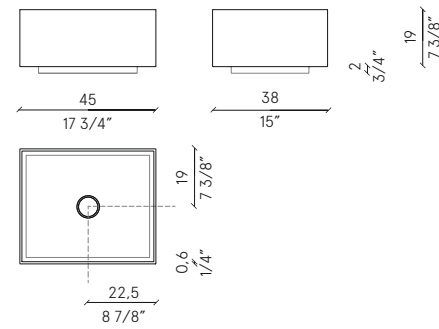

finiture | finishes | finitions | Oberflächen | отделки

sintetici | compounds | synthétiques | Kunststoff | соединений

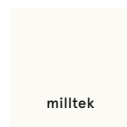

esterno argilla | external clay | extérieur argile | aussen aus Lehm | внешняя поверхность глины



STEP 45.21

SIT ON



Step 45.21

disposizione | layout | disposition | Anordnung | расположение

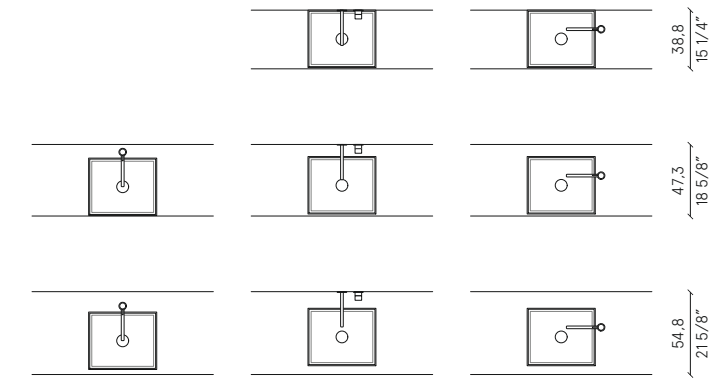
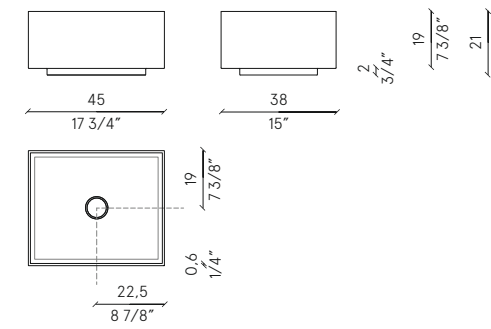

finiture | finishes | finitions | Oberflächen | отделки

sintetici | compounds | synthétiques | Kunststoff | соединений

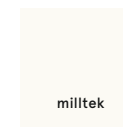

esterno argilla | external clay | extérieur argile | aussen aus Lehm | внешняя поверхность глины



STEP 63.12

SIT ON



Step 63.12

disposizione | layout | disposition | Anordnung | расположение

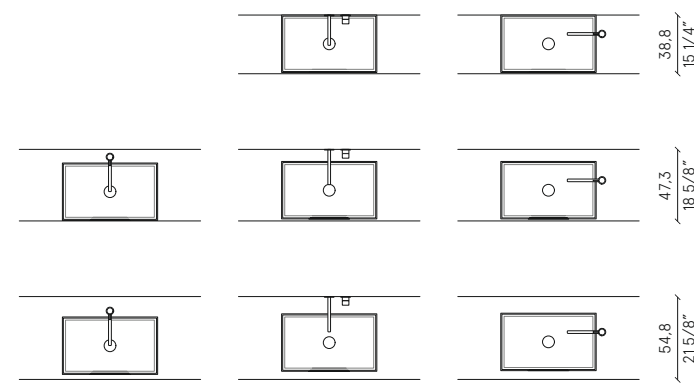
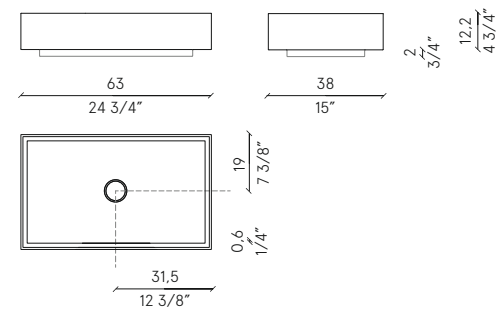

finiture | finishes | finitions | Oberflächen | отделки

sintetici | compounds | synthétiques | Kunststoff | соединений



esterno argilla | external clay | extérieur argile | aussen aus Lehm | внешняя поверхность глины



STEP 63.14

SIT ON



Step 63.14

disposizione | layout | disposition | Anordnung | расположение

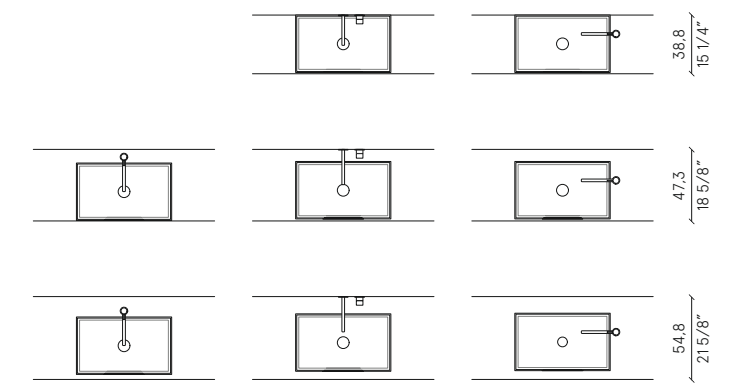
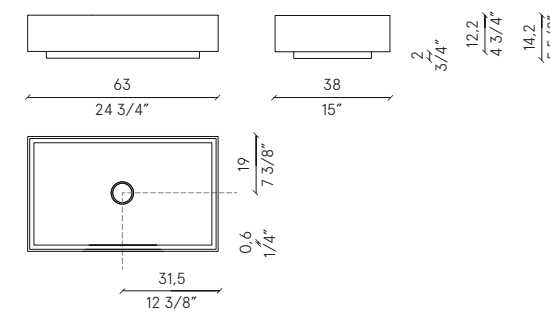

finiture | finishes | finitions | Oberflächen | отделки

sintetici | compounds | synthétiques | Kunststoff | соединений

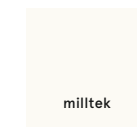

esterno argilla | external clay | extérieur argile | aussen aus Lehm | внешняя поверхность глины

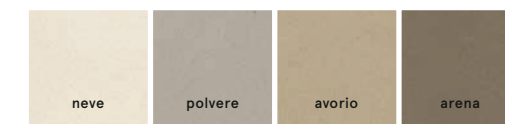

BASIC R58

SIT ON



Basic R58

disposizione | layout | disposition | Anordnung | расположение

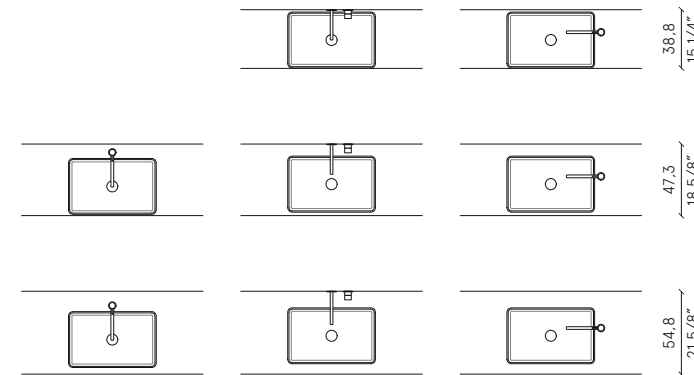
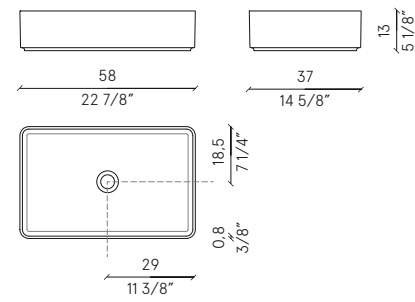

finiture | finishes | finitions | Oberflächen | отделки
 sintetici | compounds | synthétiques | Kunststoff | соединений



BASIC Q37

SIT ON



Basic Q37

disposizione | layout | disposition | Anordnung | расположение

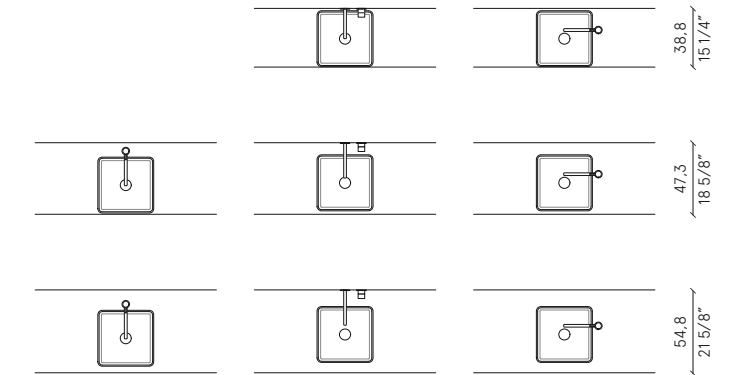
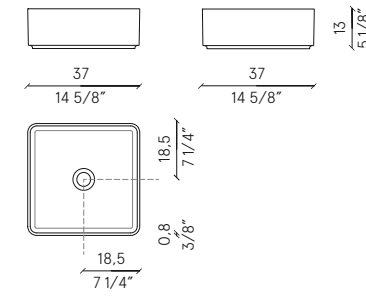

finiture | finishes | finitions | Oberflächen | отделки
 sintetici | compounds | synthétiques | Kunststoff | соединений



BASIC C37

SIT ON



Basic C37

disposizione | layout | disposition | Anordnung | расположение

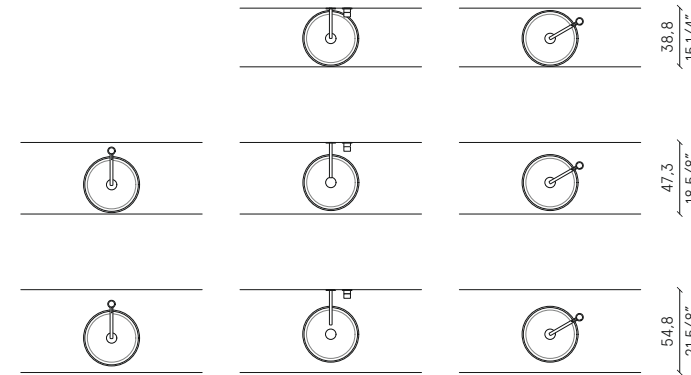
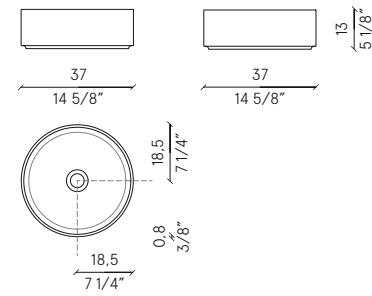

finiture | finishes | finitions | Oberflächen | отделки
 sintetici | compounds | synthétiques | Kunststoff | соединений



SKA

SIT ON



Ska

disposizione | layout | disposition | Anordnung | расположение

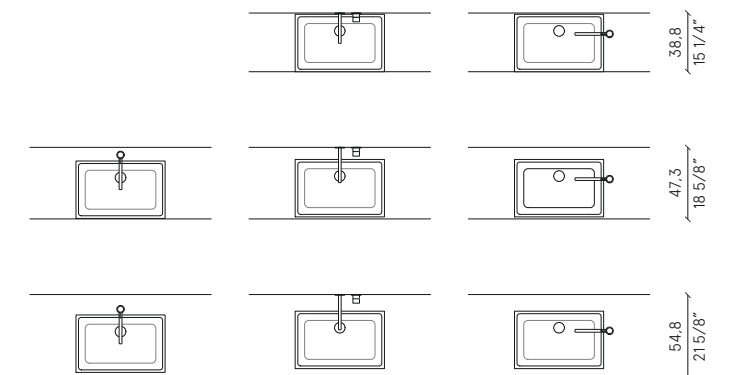
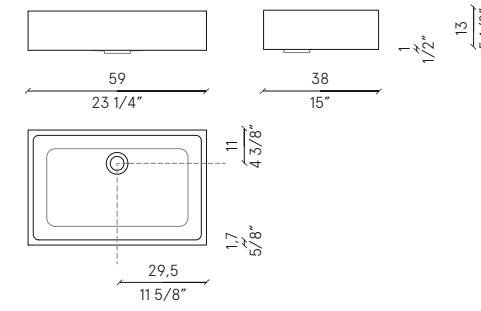

finiture | finishes | finitions | Oberflächen | отделки
 sintetici | compounds | synthétiques | Kunststoff | соединений



DEN E60

SIT ON



DEN C45

SIT ON



Den E60

disposizione | layout | disposition | Anordnung | расположение

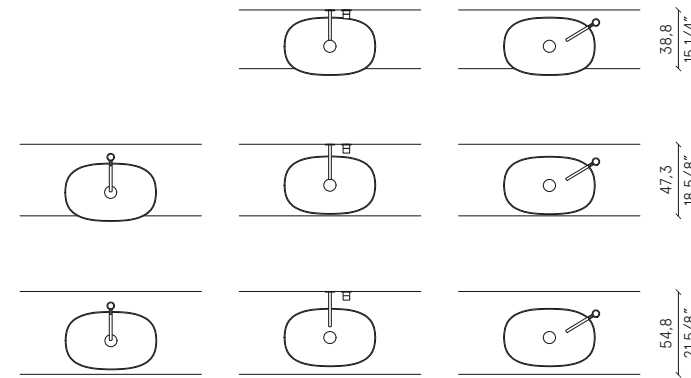
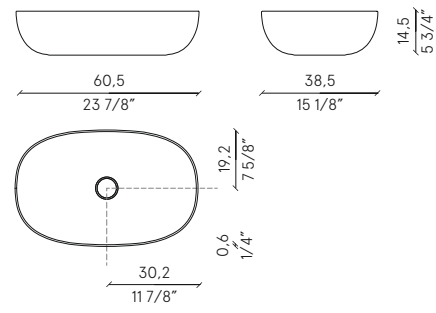

finiture | finishes | finitions | Oberflächen | отделки

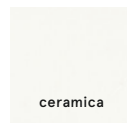

Den C45

disposizione | layout | disposition | Anordnung | расположение

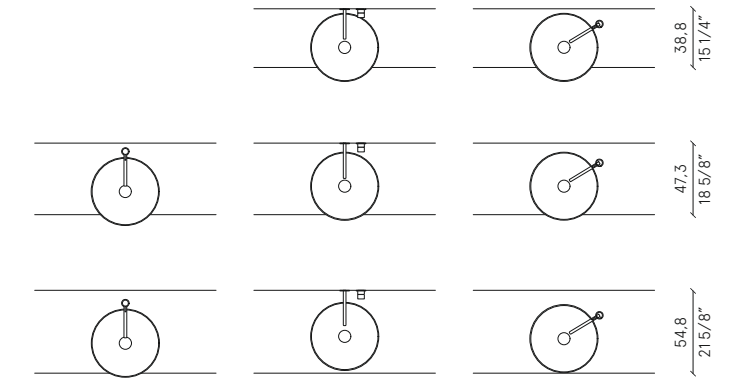
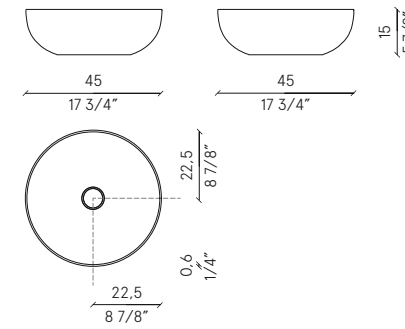

finiture | finishes | finitions | Oberflächen | отделки

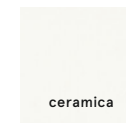

DEN R50

SIT ON



DEN Q42

SIT ON



Den R50

disposizione | layout | disposition | Anordnung | расположение

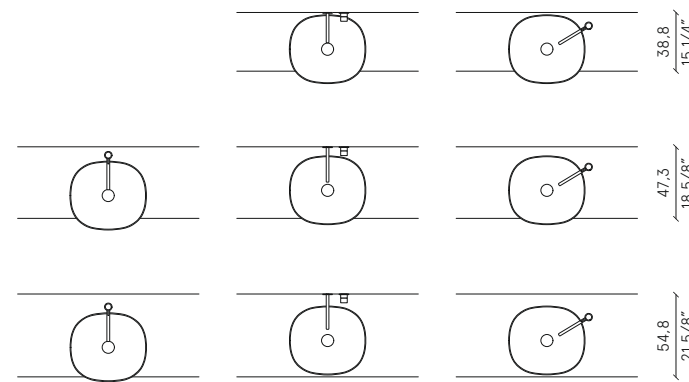
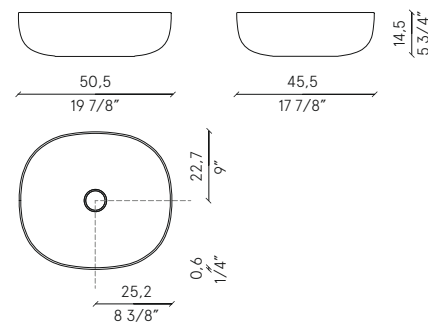

finiture | finishes | finitions | Oberflächen | отделки

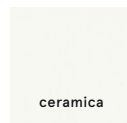

ceramica

Den Q42

disposizione | layout | disposition | Anordnung | расположение

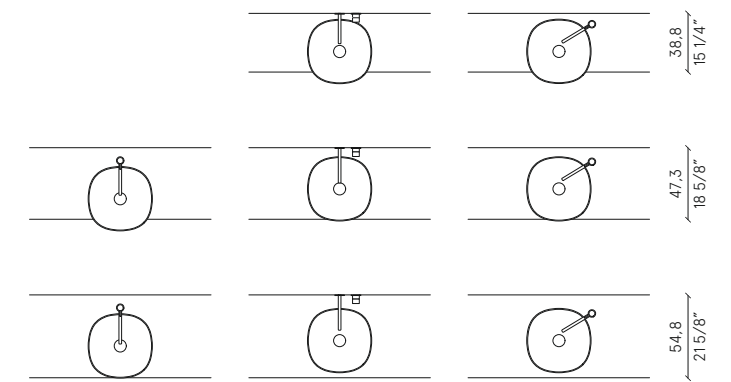
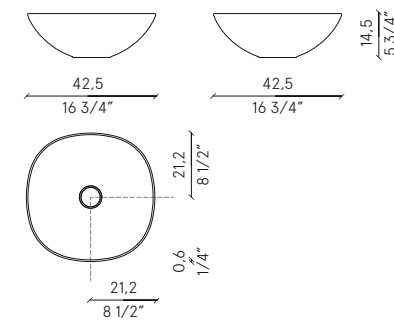

finiture | finishes | finitions | Oberflächen | отделки

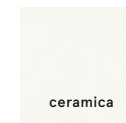

ceramica

WORLD

SIT ON



SAT

SIT ON



World

disposizione | layout | disposition | Anordnung | расположение

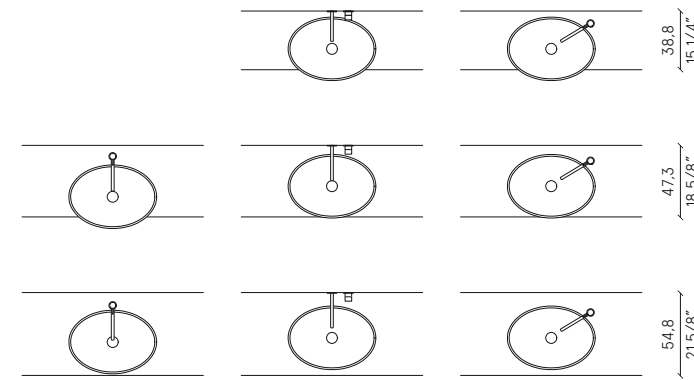
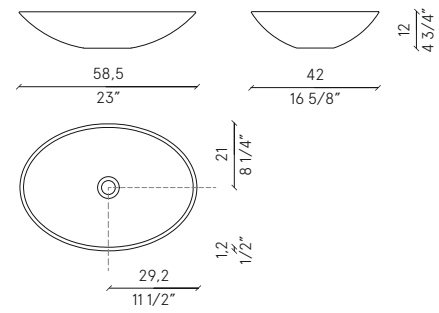

fniture | finishes | finitions | Oberflächen | отделки
sintetici | compounds | synthétiques | Kunststoff | соединений

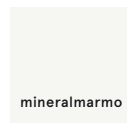

Sat

disposizione | layout | disposition | Anordnung | расположение

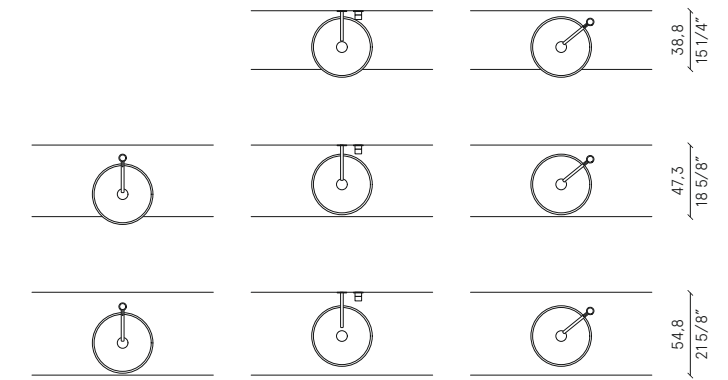
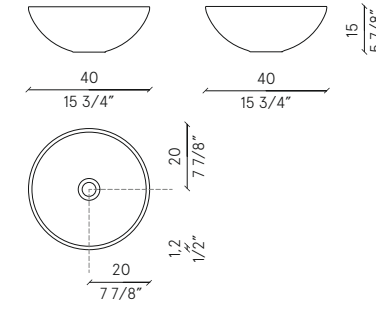

fniture | finishes | finitions | Oberflächen | отделки
sintetici | compounds | synthétiques | Kunststoff | соединений

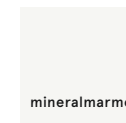

SPACE

SIT ON

BASIC R58

ABOVE COUNTER



Space

disposizione | layout | disposition | Anordnung | расположение

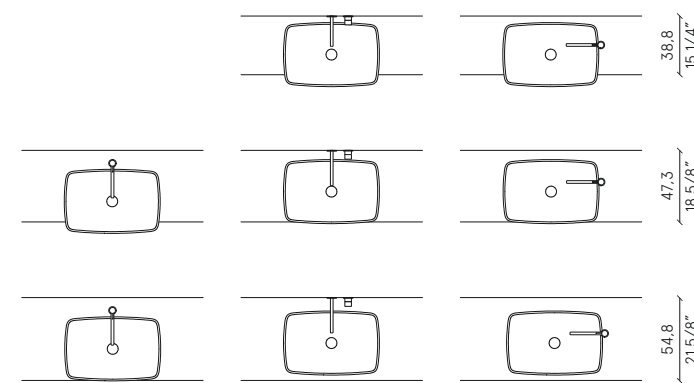
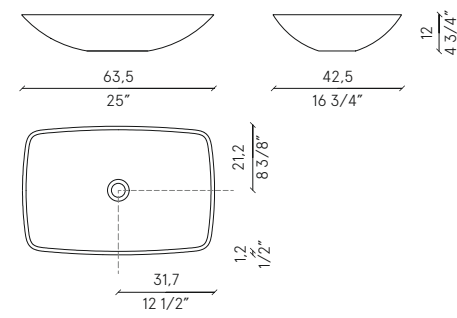

finiture | finishes | finitions | Oberflächen | отделки
 sintetici | compounds | synthétiques | Kunststoff | соединений

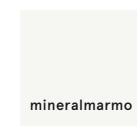

Basic R58

disposizione | layout | disposition | Anordnung | расположение

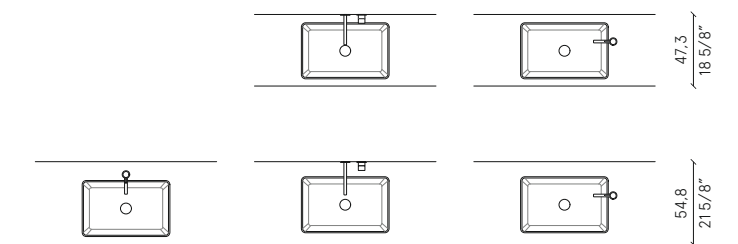
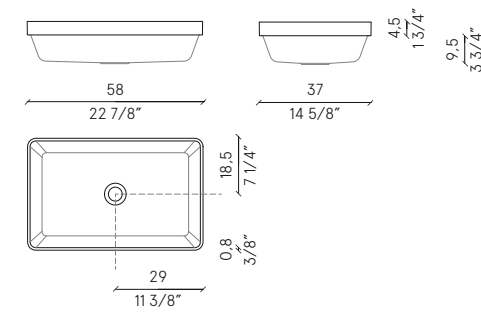

finiture | finishes | finitions | Oberflächen | отделки
 sintetici | compounds | synthétiques | Kunststoff | соединений



BASIC Q37

ABOVE COUNTER



Basic Q37

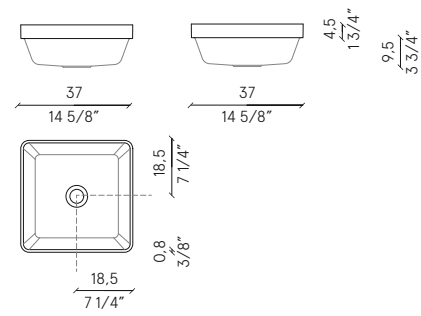

disposizione | layout | disposition | Anordnung | расположение

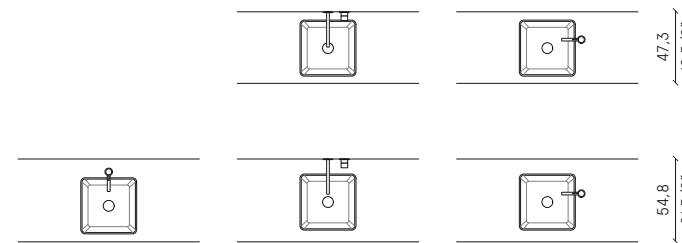

finiture | finishes | finitions | Oberflächen | отделки

sintetici | compounds | synthétiques | Kunststoff | соединений



BASIC C37

ABOVE COUNTER



Basic C37

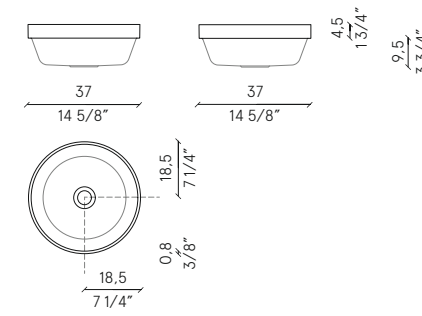

disposizione | layout | disposition | Anordnung | расположение

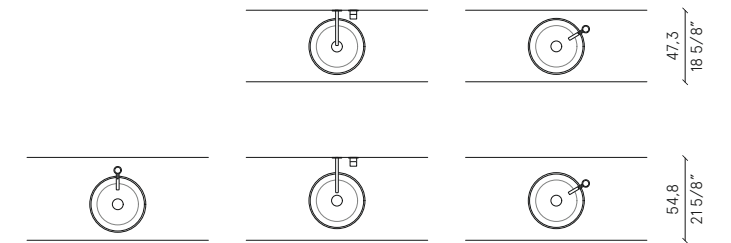

finiture | finishes | finitions | Oberflächen | отделки

sintetici | compounds | synthétiques | Kunststoff | соединений



SKA

ABOVE COUNTER



NET

ABOVE COUNTER



Ska

disposizione | layout | disposition | Anordnung | расположение

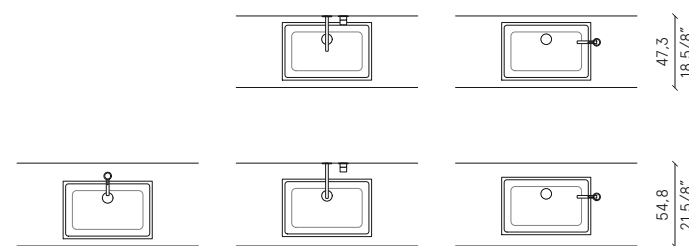
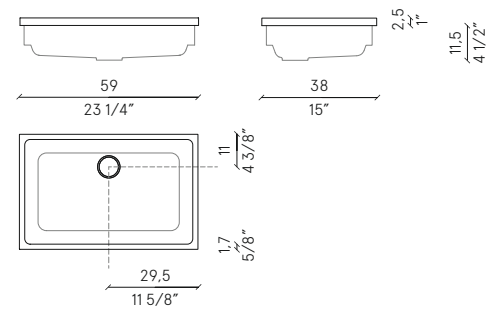

finiture | finishes | finitions | Oberflächen | отделки
 sintetici | compounds | synthétiques | Kunststoff | соединений

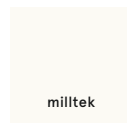

Net

disposizione | layout | disposition | Anordnung | расположение

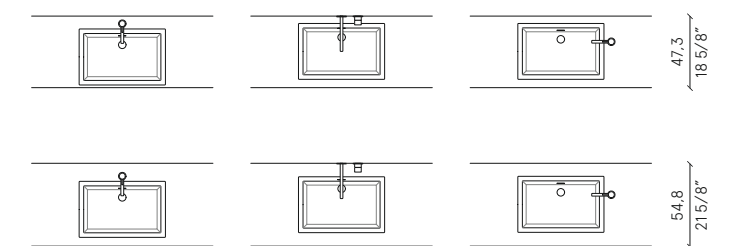
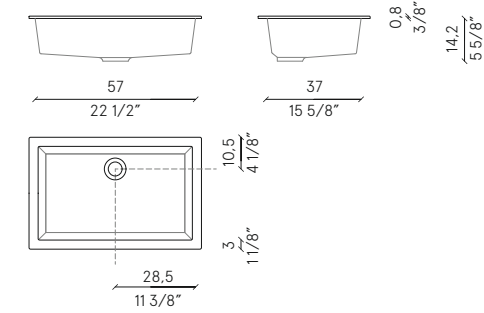

finiture | finishes | finitions | Oberflächen | отделки

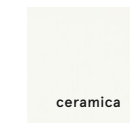

NET

INSET



BLOX

INSET



Net

disposizione | layout | disposition | Anordnung | расположение

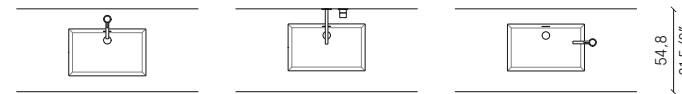
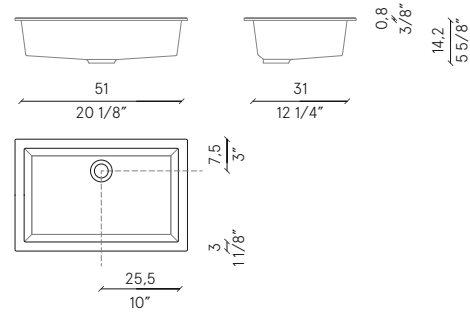

finiture | finishes | finitions | Oberflächen | отделки



Blox

disposizione | layout | disposition | Anordnung | расположение

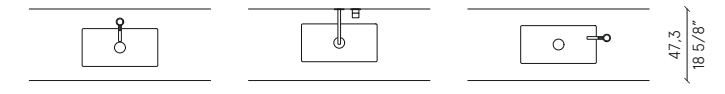
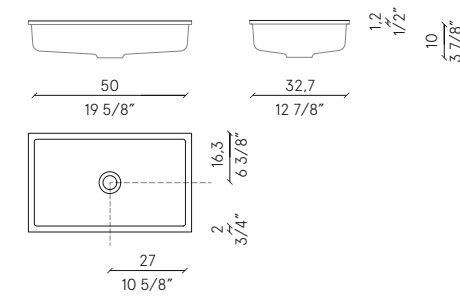

finiture | finishes | finitions | Oberflächen | отделки

sinetici | compounds | synthétiques | Kunststoff | соединений

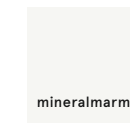

PROP 17

SEMI-INSET



Prop 17

disposizione | layout | disposition | Anordnung | расположение

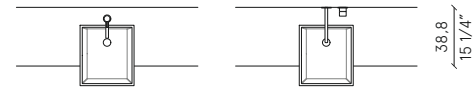
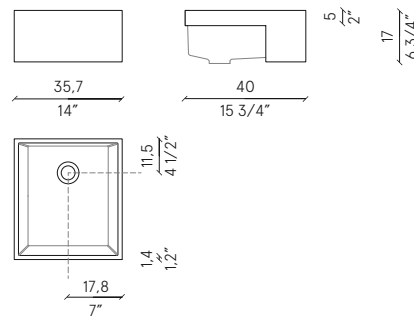

finiture | finishes | finitions | Oberflächen | отделки

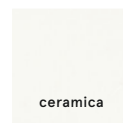

ceramica

PROP 49

SEMI-INSET



Prop 49

disposizione | layout | disposition | Anordnung | расположение

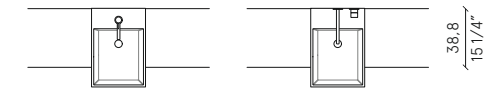
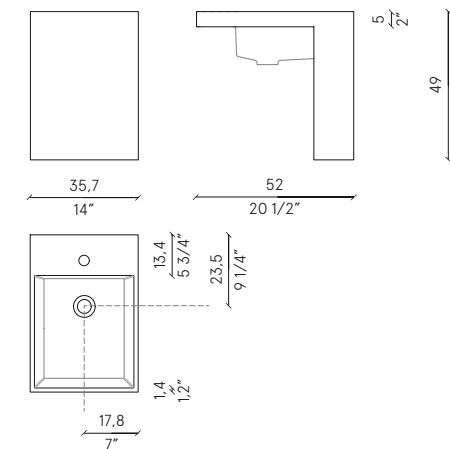

finiture | finishes | finitions | Oberflächen | отделки

sinetici | compounds | synthétiques | Kunststoff | соединений

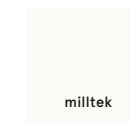

milltek

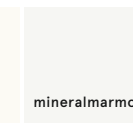

mineralmarmo

SKA

SEMI-INSET



Ska

disposizione | layout | disposition | Anordnung | расположение

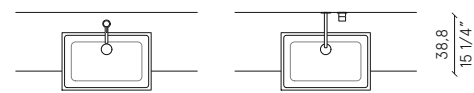
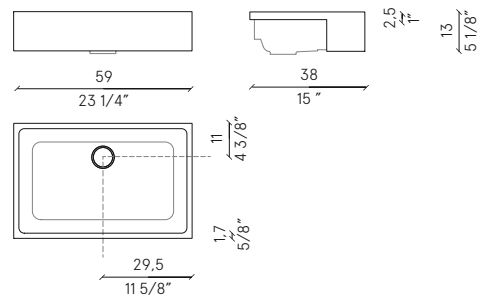

finiture | finishes | finitions | Oberflächen | отделки
 sintetici | compounds | synthétiques | Kunststoff | соединений

milltek

TUBE

FLOOR-STANDING



Tube

disposizione | layout | disposition | Anordnung | расположение

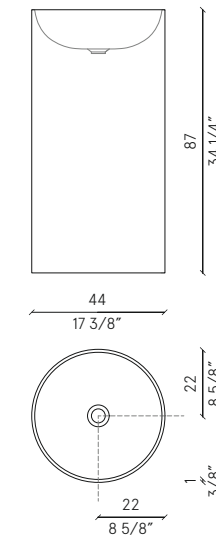

finiture | finishes | finitions | Oberflächen | отделки
 sintetici | compounds | synthétiques | Kunststoff | соединений

milltek

Superfici continue, personalizzabili nelle dimensioni e negli spessori, piani che si sviluppano longitudinalmente integrando lavabi di diversa geometria e forma senza soluzione di continuità: i top proposti da Noorth esprimono l'essenzialità del linguaggio del brand, sottolineando la propria presenza nello spazio attraverso l'uniformità cromatica dei materiali sintetici, le trasparenze e i riflessi del vetro o le tracce uniche e irripetibili del marmo. Sospesi o integrati a mobili e contenitori, possono ospitare una o più vasche, definendo identità e stile dell'ambiente bagno.

Continuous surfaces, customizable in size and thickness, layers that extend lengthwise thereby seamlessly integrating washbasins of different shapes and dimensions: Noorth presents a range of tops that convey the essence of the brand's vision, emphasizing its presence inside the interior spaces through the consistency of color of synthetic materials, the transparencies and reflections of glass or the unique and unrepeatable streaks typical of marble. Whether wall-mounted or built into furniture and storage units, they can house one or more tubs, defining the identity and style of each bathroom.

Surfaces continues aux dimensions et aux épaisseurs personnalisables, plans se développant longitudinalement pour intégrer des lavabos de différentes formes et géométries sans solution de continuité : les plans signés Noorth expriment l'essence du langage de la marque tout en marquant sa présence dans l'espace grâce à l'uniformité chromatique des matériaux synthétiques, les transparences et les reflets du verre ou les veines uniques et inimitables du marbre. Suspendus ou intégrés aux meubles ou aux éléments de rangement, les plans Noorth peuvent accueillir une ou plusieurs vasques, définissant ainsi l'identité et le style de la salle de bain.

Durchgehende Flächen, die auf individuelle Ansprüche in Größe und Dicke gefertigt werden können, längsverlaufende Platten, in die Waschbecken unterschiedlicher Form eingearbeitet werden können: Die von Noorth präsentierten Einfassungen sind die treue Wiedergabe der unverwechselbaren Wesensart der Marke. Sie zeichnen sich durch die farbliche Übereinstimmung der verwendeten synthetischen Materialien, die Lichtdurchlässigkeit und die Spiegelungen des Glases und die chromatische Einzigartigkeit des Marmors aus. In Möbel integriert oder hängend bieten sie Raum für ein oder mehrere Becken und verleihen dem Bad seinen unverwechselbaren Charakter.

Непрерывные поверхности, с индивидуальными размерами и толщинами, простирающиеся в продольном направлении плоскости, интегрирующие раковины различной геометрии и формы: столешницы Noorth выражают всю сущность стиля бренда, подчеркивая собственное присутствие в помещении посредством хроматической однородности синтетических материалов, прозрачных элементов и отражений стекла, уникальных и неповторимых рисунков мрамора. Подвесные или интегрированные в мебель, они могут размещать одну или несколько раковин, определяя стиль ванной.



Tray 35 | Tray 58 | Tray 94

con piano copripiletta | with drain cover | avec plan cache-bond | mit Abfluss Abdeckung | плоская крышка слива

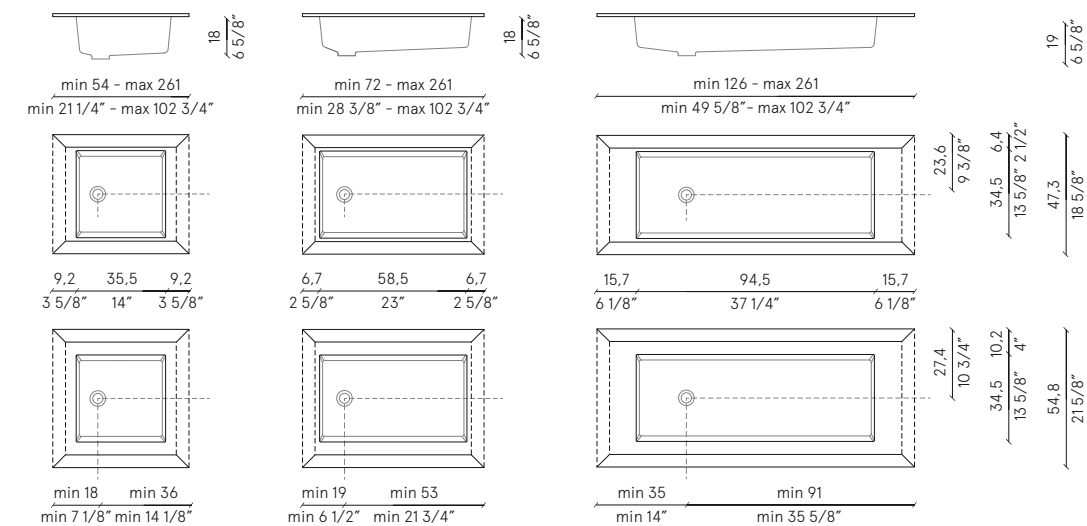

fniture | finishes | fnitions | Oberflächen | отделки
sintetici | compounds | synthétiques | Kunststoff | соединений

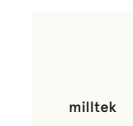

due vasche | two basins | deux vasques | zwei Becken | два раковины top | plan | Platte | столешница
L top | W top | L plan | B Platte | Ш столешница
sp. | th. | sp. | Di. | тол.

Tray 35 + Tray 35 = min 108 cm | 42 1/2"
Tray 58 + Tray 58 = min 144 cm | 56 7/8"
Tray 94 + Tray 94 = min 252 cm | 99 1/4"

SINTESI 1,9 3/4"
PURO 1,9 3/4"

INFINITY

SIT ON TOP



Infinity

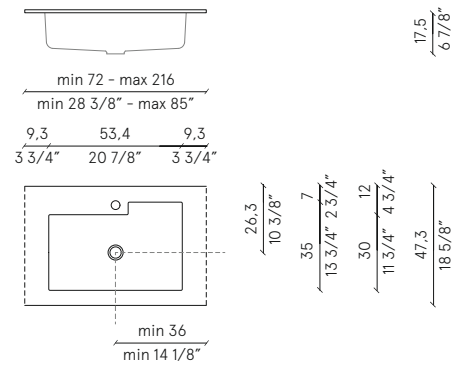

finiture | finishes | finitions | Oberflächen | отделки
sintetici | compounds | synthétiques | Kunststoff | соединений



due vasche | two basins | deux vasques | zwei Becken | два раковины
L top | W top | L plan | B Platte | Ш столешница
Infinity + Infinity = min 144 cm | 56 3/4"

top | plan | Platte | столешница
sp. | th. | sp. | Di. | тол.
SINTESI 1.2 1/2"
PURO 1.9 3/4"

INFINITY 10

SIT ON TOP



Infinity

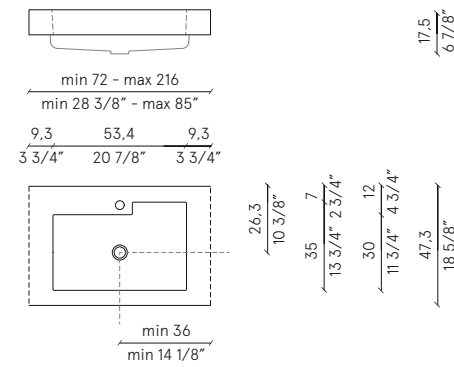

finiture | finishes | finitions | Oberflächen | отделки
sintetici | compounds | synthétiques | Kunststoff | соединений



due vasche | two basins | deux vasques | zwei Becken | два раковины
L top | W top | L plan | B Platte | Ш столешница
Infinity + Infinity = min 144 cm | 56 3/4"

top | plan | Platte | столешница
sp. | th. | sp. | Di. | тол.
10 3 7/8"

STAGE

SIT ON TOP



STAGE 10

SIT ON TOP



Stage 01 | Stage 02 | Stage 03 | Stage 04 | Stage 05 | Stage 06

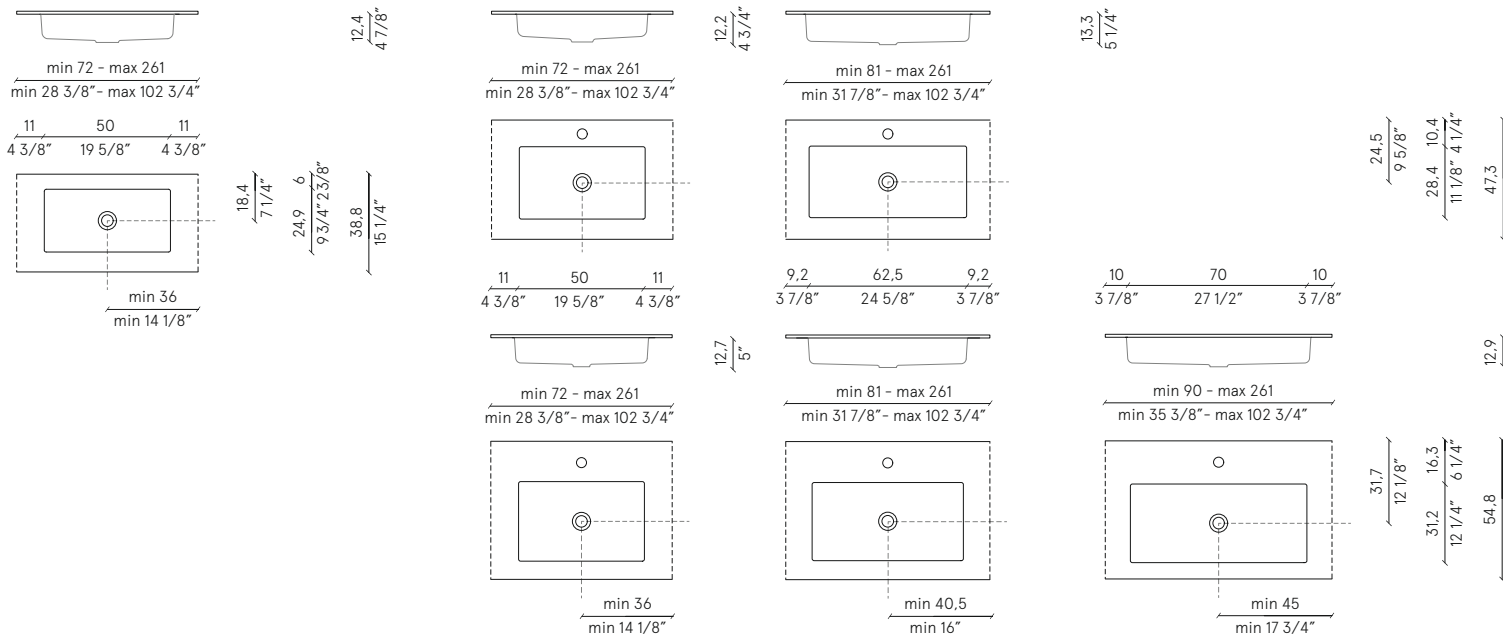

fniture | finishes | finitions | Oberflächen | отделки
sintetici | compounds | synthétiques | Kunststoff | соединений



due vasche | two basins | deux vasques | zwei Becken | два раковины
L top | W top | L plan | B Platte | Ш столешница

Stage 01 + Stage 01 = min 144 cm | 56 3/4"
Stage 02 + Stage 02 = min 144 cm | 56 3/4"
Stage 03 + Stage 03 = min 162 cm | 63 3/4"
Stage 04 + Stage 04 = min 144 cm | 56 3/4"
Stage 05 + Stage 05 = min 162 cm | 63 3/4"
Stage 06 + Stage 06 = min 180 cm | 70 7/8"

top | plan | Platte | столешница
sp. | th. | sp. | Di. | тол.

SINTESI 1.2, 1/2"
PURO 1.9, 3/4"

Stage 01 | Stage 02 | Stage 03 | Stage 04 | Stage 05 | Stage 06

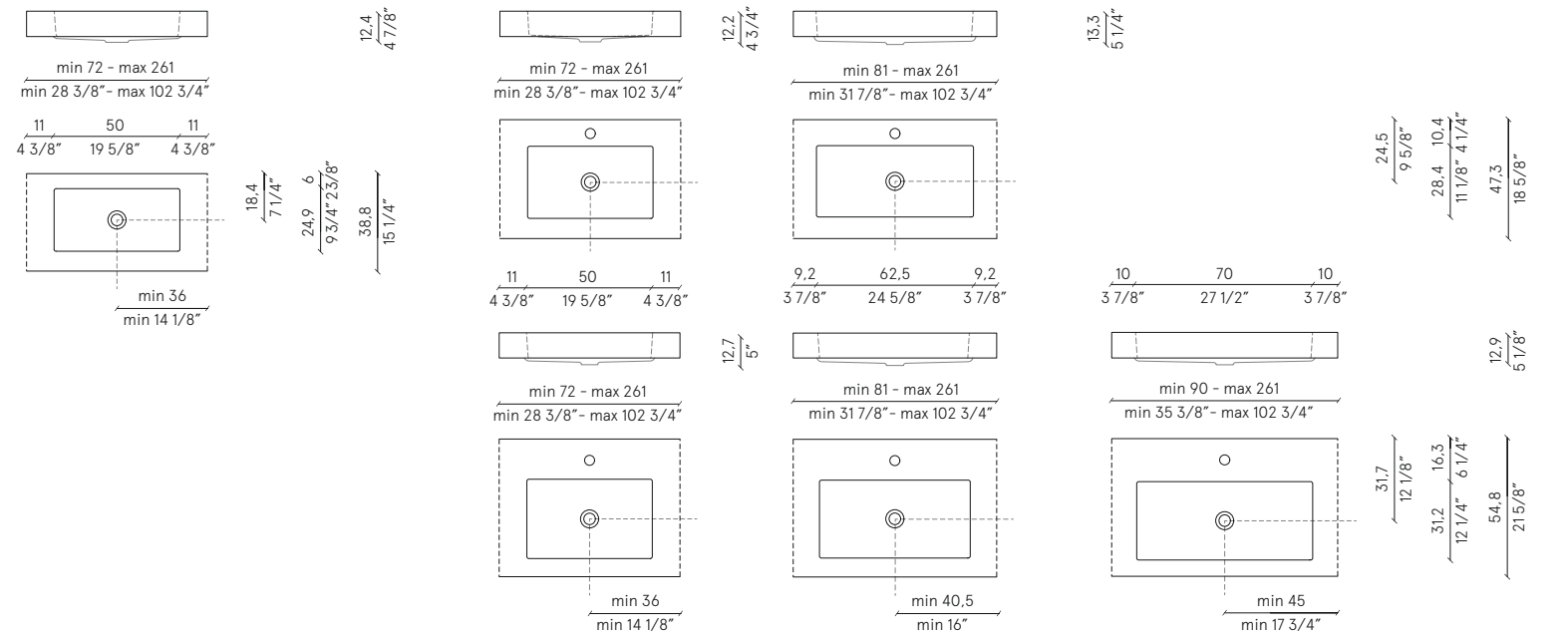

fniture | finishes | finitions | Oberflächen | отделки
sintetici | compounds | synthétiques | Kunststoff | соединений



due vasche | two basins | deux vasques | zwei Becken | два раковины
L top | W top | L plan | B Platte | Ш столешница

Stage 01 + Stage 01 = min 144 cm | 56 3/4"
Stage 02 + Stage 02 = min 144 cm | 56 3/4"
Stage 03 + Stage 03 = min 162 cm | 63 3/4"
Stage 04 + Stage 04 = min 144 cm | 56 3/4"
Stage 05 + Stage 05 = min 162 cm | 63 3/4"
Stage 06 + Stage 06 = min 180 cm | 70 7/8"

top | plan | Platte | столешница
sp. | th. | sp. | Di. | тол.

10, 3 7/8"

NEAT

SIT ON TOP



NEAT 10

SIT ON TOP



Neat 01 | Neat 02

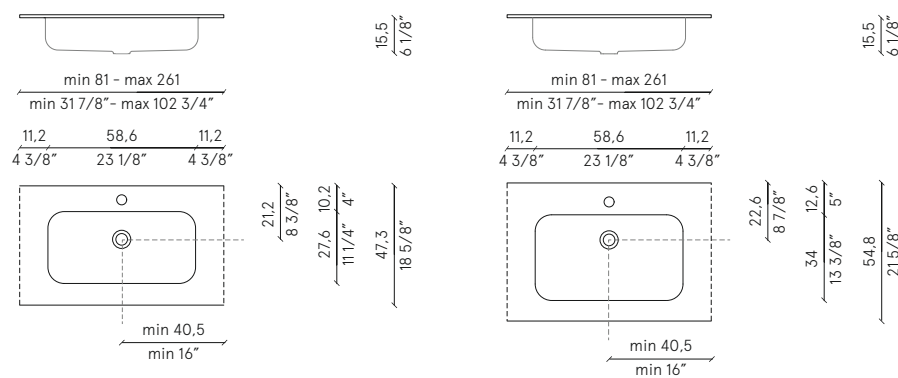

fniture | finishes | fnitions | Oberflächen | отделки
sintetici | compounds | synthétiques | Kunststoff | соединений



due vasche | two basins | deux vasques | zwei Becken | два раковины
L top | W top | L plan | B Platte | Ш столешница
sp. | th. | sp. | Di. | тол.

Neat 01 + Neat 01 = min 162 cm | 63 3/4"
Neat 02 + Neat 02 = min 162 cm | 63 3/4"

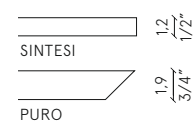

Neat 01 | Neat 02

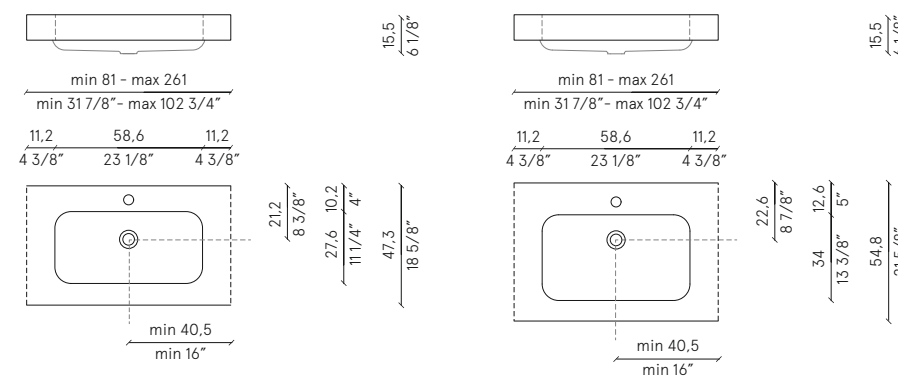

fniture | finishes | fnitions | Oberflächen | отделки
sintetici | compounds | synthétiques | Kunststoff | соединений



due vasche | two basins | deux vasques | zwei Becken | два раковины
L top | W top | L plan | B Platte | Ш столешница
sp. | th. | sp. | Di. | тол.

Neat 01 + Neat 01 = min 162 cm | 63 3/4"
Neat 02 + Neat 02 = min 162 cm | 63 3/4"

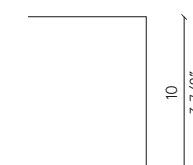

ROUND

SIT ON TOP



Round 01 | Round 02

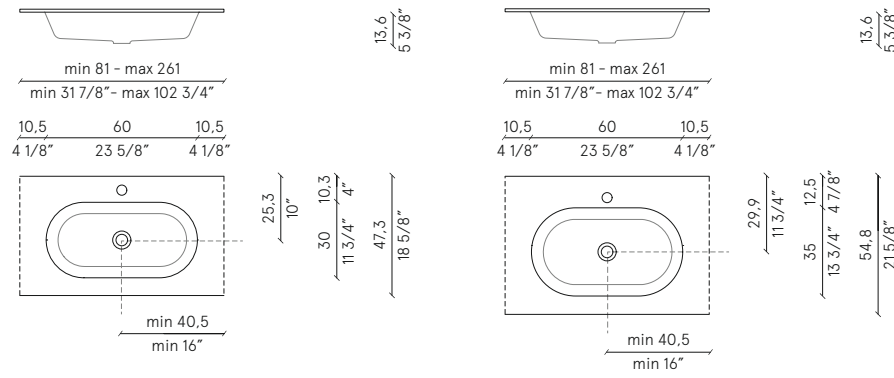

finiture | finishes | finitions | Oberflächen | отделки
 sintetici | compounds | synthétiques | Kunststoff | соединений



due vasche | two basins | deux vasques | zwei Becken | два раковины
 L top | W top | L plan | B Platte | Ш столешница
 Round 01 + Round 01 = min 162 cm | 63 3/4"
 Round 02 + Round 02 = min 162 cm | 63 3/4"

top | plan | Platte | столешница
 sp. | th. | sp. | Di. | тол.
 SINTESI 1,2 (1/2")
 PURO 1,9 (3/4")

ROUND 10

SIT ON TOP



Round 01 | Round 02

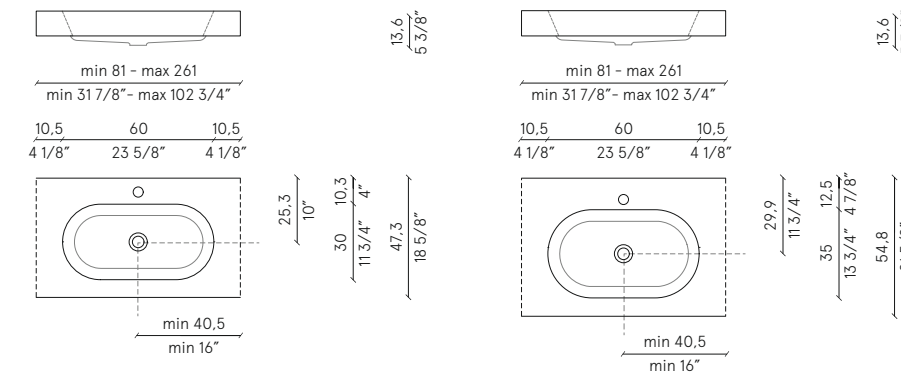

finiture | finishes | finitions | Oberflächen | отделки
 sintetici | compounds | synthétiques | Kunststoff | соединений



due vasche | two basins | deux vasques | zwei Becken | два раковины
 L top | W top | L plan | B Platte | Ш столешница
 Round 01 + Round 01 = min 162 cm | 63 3/4"
 Round 02 + Round 02 = min 162 cm | 63 3/4"

top | plan | Platte | столешница
 sp. | th. | sp. | Di. | тол.
 10 (3 7/8")

SPAN

SIT ON TOP



SPAN 10

SIT ON TOP



Span 01 | Span 02 | Span 03 | Span 04

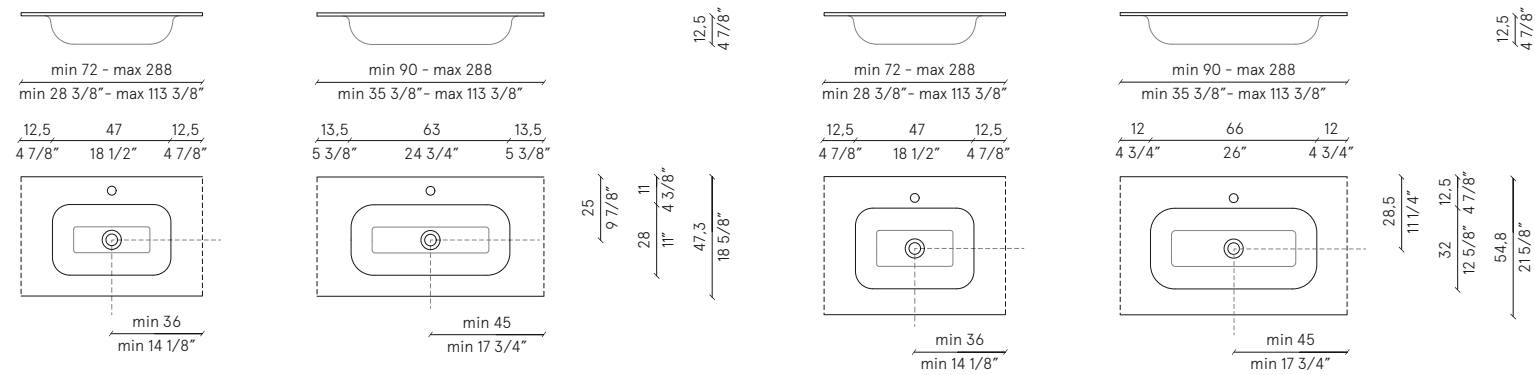

finiture | finishes | finitions | Oberflächen | отделки
sintetici | compounds | synthétiques | Kunststoff | соединений

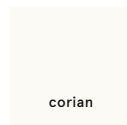

due vasche | two basins | deux vasques | zwei Becken | два раковины
L top | W top | L plan | B Platte | Ш столешница
sp. | th. | sp. | Di. | тол.

Span 01 + Span 01 = min 144 cm | 56 3/4"
Span 02 + Span 02 = min 180 cm | 70 7/8"
Span 03 + Span 03 = min 144 cm | 56 3/4"
Span 04 + Span 04 = min 180 cm | 70 7/8"

SINTESI
PURO

Span 01 | Span 02 | Span 03 | Span 04

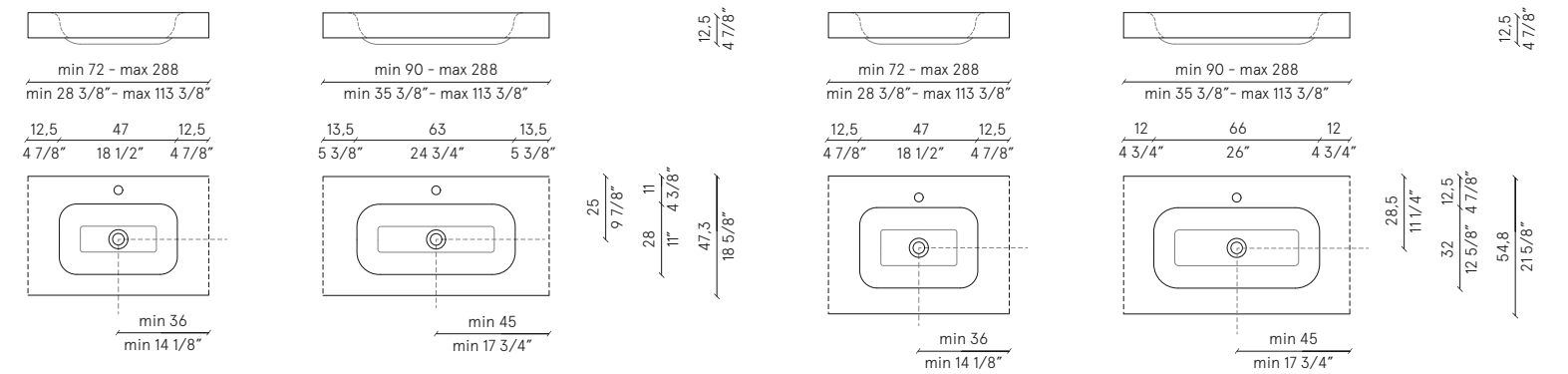

finiture | finishes | finitions | Oberflächen | отделки
sintetici | compounds | synthétiques | Kunststoff | соединений

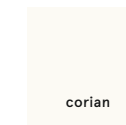

due vasche | two basins | deux vasques | zwei Becken | два раковины
L top | W top | L plan | B Platte | Ш столешница
sp. | th. | sp. | Di. | тол.

Span 01 + Span 01 = min 144 cm | 56 3/4"
Span 02 + Span 02 = min 180 cm | 70 7/8"
Span 03 + Span 03 = min 144 cm | 56 3/4"
Span 04 + Span 04 = min 180 cm | 70 7/8"

10
3 7/8"

DIP

SIT ON TOP



DIP 10

SIT ON TOP



Dip 35 | Dip 58 | Dip 94

con piano copripiletta | with drain cover | avec plan cache-bond | mit Abfluss Abdeckung | плоская крышка слива

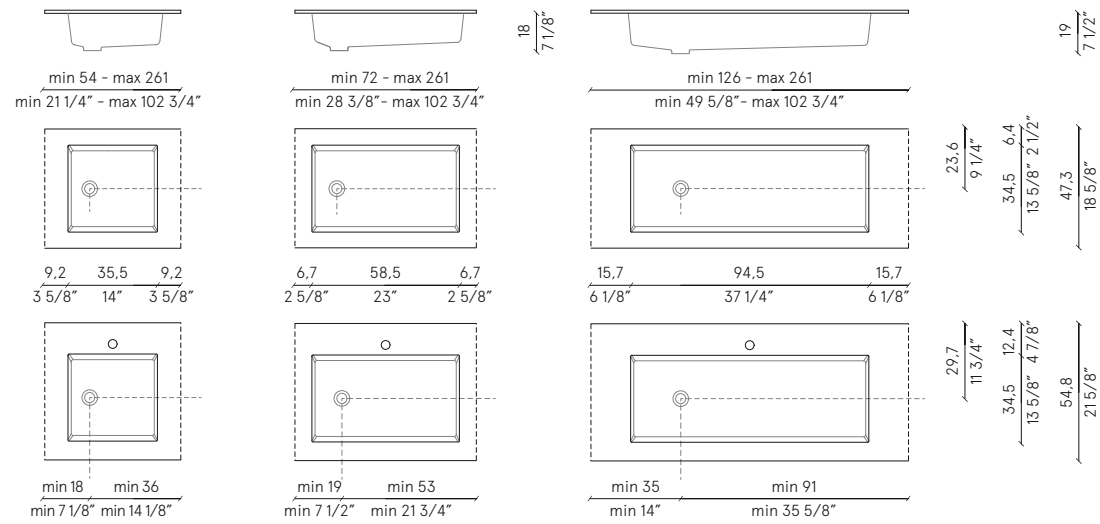

finiture | finishes | finitions | Oberflächen | отделки
 sintetici | compounds | synthétiques | Kunststoff | соединений

due vasche | two basins | deux vasques | zwei Becken | два раковины
 L top | W top | L plan | B Platte | Ш столешница

Dip 35 + Dip 35 = min 108 cm | 42 1/2"
 Dip 58 + Dip 58 = min 144 cm | 56 3/4"
 Dip 94 + Dip 94 = min 252 cm | 99 1/4"

top | plan | Platte | столешница
 sp. | th. | sp. | Di. | тол.

SINTESI 1.2 / 1/2"
 PURO 1.9 / 3/4"

milltek

Dip 35 | Dip 58 | Dip 94

con piano copripiletta | with drain cover | avec plan cache-bond | mit Abfluss Abdeckung | плоская крышка слива

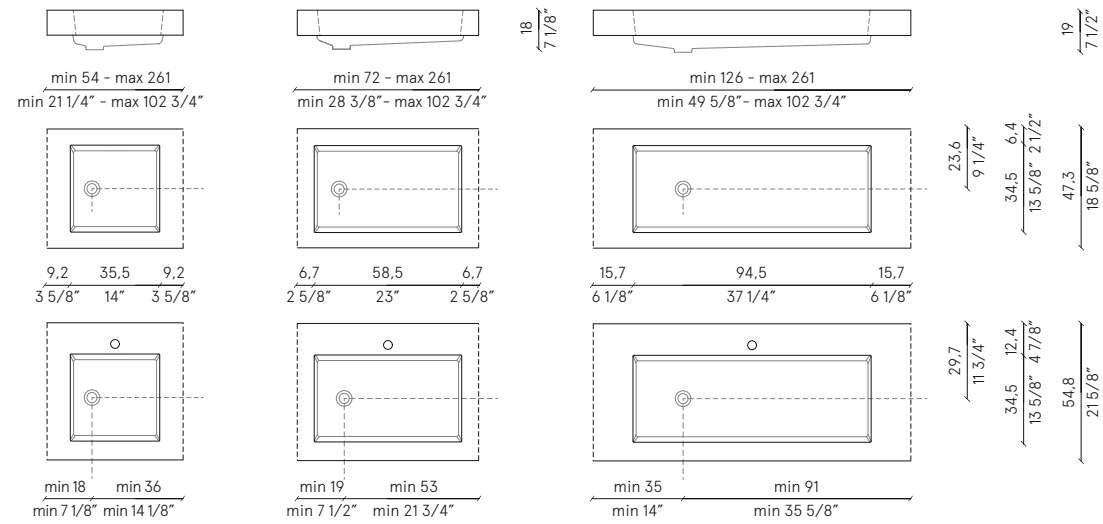

finiture | finishes | finitions | Oberflächen | отделки
 sintetici | compounds | synthétiques | Kunststoff | соединений

due vasche | two basins | deux vasques | zwei Becken | два раковины
 L top | W top | L plan | B Platte | Ш столешница

Dip 35 + Dip 35 = min 108 cm | 42 1/2"
 Dip 58 + Dip 58 = min 144 cm | 56 3/4"
 Dip 94 + Dip 94 = min 252 cm | 99 1/4"

top | plan | Platte | столешница
 sp. | th. | sp. | Di. | тол.

10 / 3 7/8"

milltek

LAND

SIT ON TOP



Land 01 | Land 02

con piano copripiletta | with drain cover | avec plan cache-bond | mit Abfluss Abdeckung | плоская крышка слива

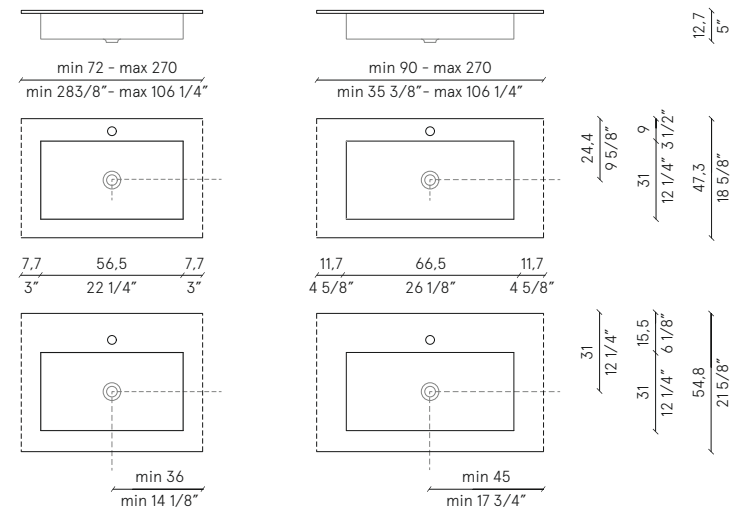

finiture | finishes | finitions | Oberflächen | отделки
argille | clays | argiles | Lehm | глины



due vasche | two basins | deux vasques | zwei Becken | два раковины
L top | W top | L plan | B Platte | Ш столешница

Land 01 + Land 01 = min 144 cm | 56 3/4"
Land 02 + Land 02 = min 180 cm | 70 7/8"

top | plan | Platte | столешница
sp. | th. | sp. | Di. | тол.

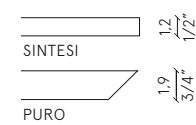

LAND 10

SIT ON TOP



Land 01 | Land 02

con piano copripiletta | with drain cover | avec plan cache-bond | mit Abfluss Abdeckung | плоская крышка слива

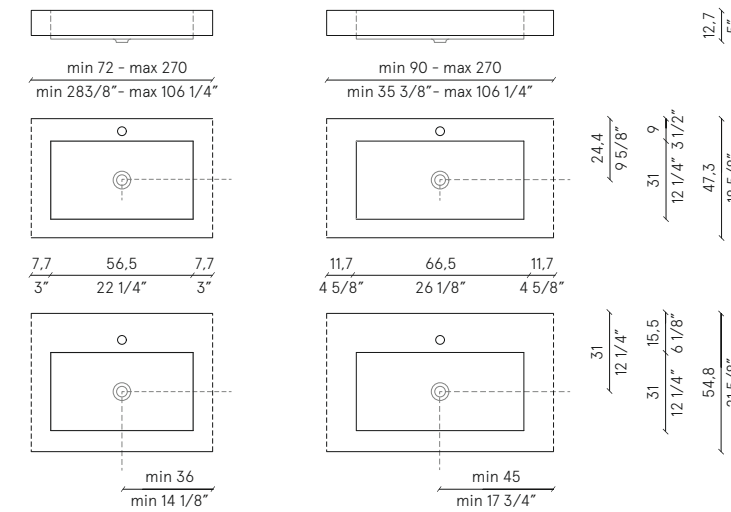

finiture | finishes | finitions | Oberflächen | отделки
argille | clays | argiles | Lehm | глины



due vasche | two basins | deux vasques | zwei Becken | два раковины
L top | W top | L plan | B Platte | Ш столешница

Land 01 + Land 01 = min 144 cm | 56 3/4"
Land 02 + Land 02 = min 180 cm | 70 7/8"

top | plan | Platte | столешница
sp. | th. | sp. | Di. | тол.

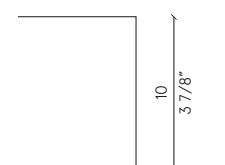

STILL

SIT ON TOP



Still 01 | Still 02 | Still 03 | Still 04

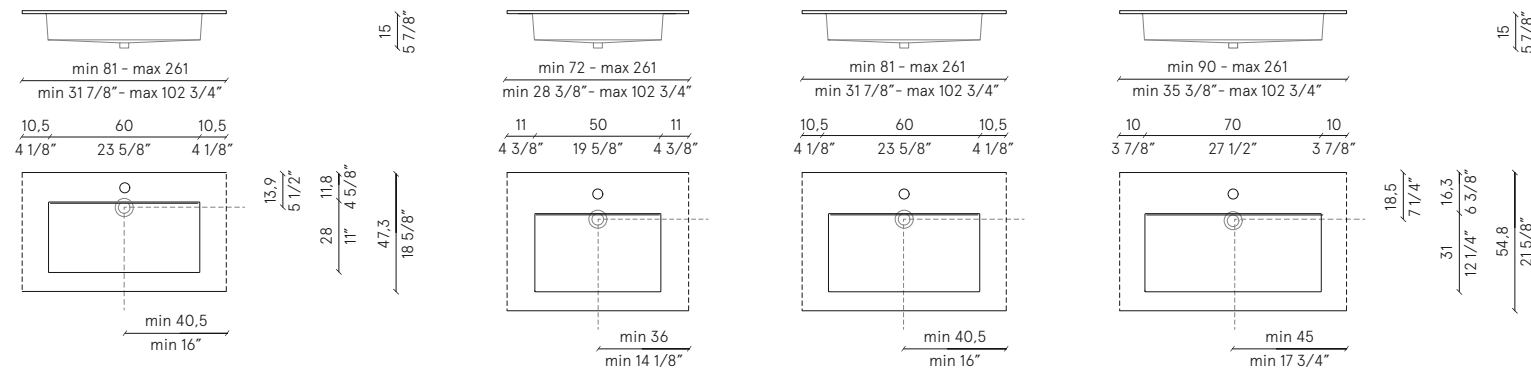

fniture | finishes | finitions | Oberflächen | отделки
 sintetici | compounds | synthétiques | Kunststoff | соединений



due vasche | two basins | deux vasques | zwei Becken | два раковины
 L top | W top | L plan | B Platte | Ш столешница

Still 01 + Still 01 = min 162 cm | 63 3/4"
 Still 02 + Still 02 = min 144 cm | 56 3/4"
 Still 03 + Still 03 = min 162 cm | 63 3/4"
 Still 04 + Still 04 = min 180 cm | 70 7/8"

top | plan | Platte | столешница
 sp. | th. | sp. | Di. | тол.
 SINTESI 1,2 | 1 1/2"
 PURO 1,9 | 3/4"

STILL 10

SIT ON TOP



Still 01 | Still 02 | Still 03 | Still 04

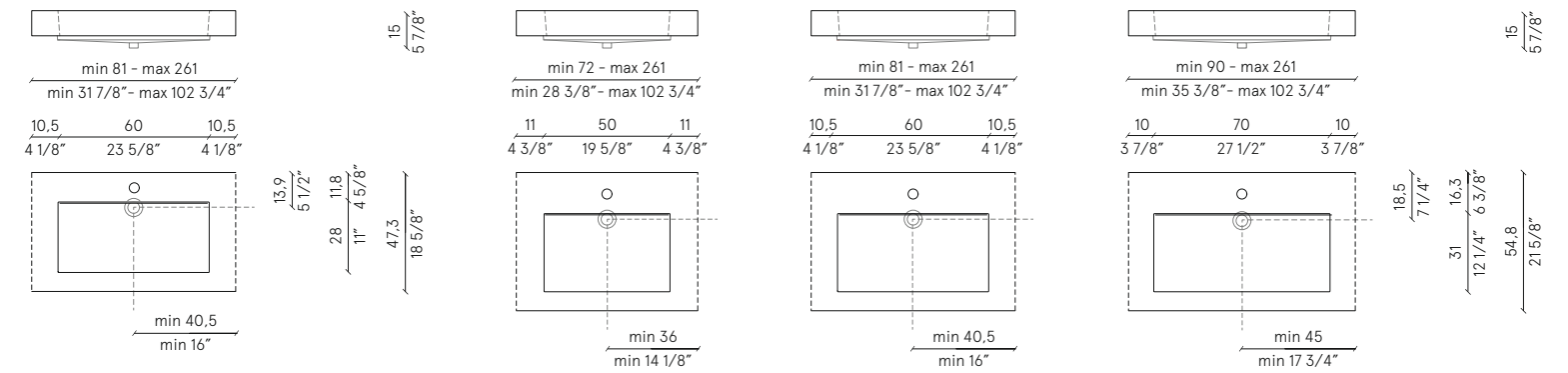

fniture | finishes | finitions | Oberflächen | отделки
 sintetici | compounds | synthétiques | Kunststoff | соединений



due vasche | two basins | deux vasques | zwei Becken | два раковины
 L top | W top | L plan | B Platte | Ш столешница

Still 01 + Still 01 = min 162 cm | 63 3/4"
 Still 02 + Still 02 = min 144 cm | 56 3/4"
 Still 03 + Still 03 = min 162 cm | 63 3/4"
 Still 04 + Still 04 = min 180 cm | 70 7/8"

top | plan | Platte | столешница
 sp. | th. | sp. | Di. | тол.
 10 | 3 7/8"

NEXT

SIT ON TOP



NEXT 10

SIT ON TOP



Next 56 | Next 90 | Next 110

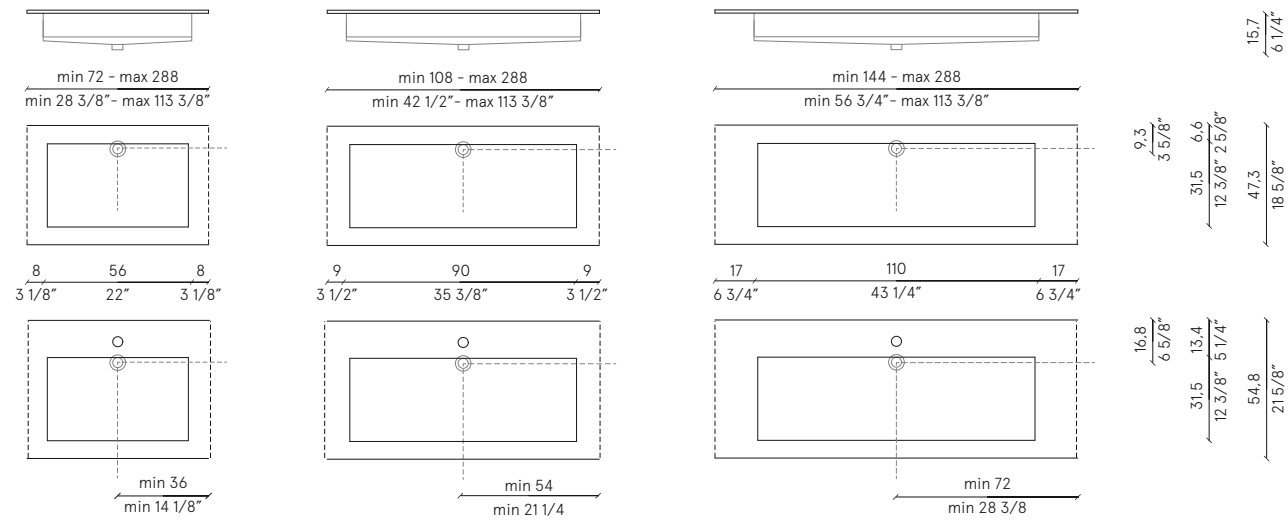

fniture | finishes | finitions | Oberflächen | отделки
sintetici | compounds | synthétiques | Kunststoff | соединений



due vasche | two basins | deux vasques | zwei Becken | два раковины
L top | W top | L plan | B Platte | Ш столешница
Next 56 + Next 56 = min 144 cm | 56 3/4"
Next 90 + Next 90 = min 180 cm | 70 7/8"
Next 110 + Next 110 = min 288 cm | 113 3/8"

top | plan | Platte | столешница
sp. | th. | sp. | Di. | тол.
SINTESI 1.2 / 1/2"
PURO 1.9 / 3/4"

Next 56 | Next 90 | Next 110

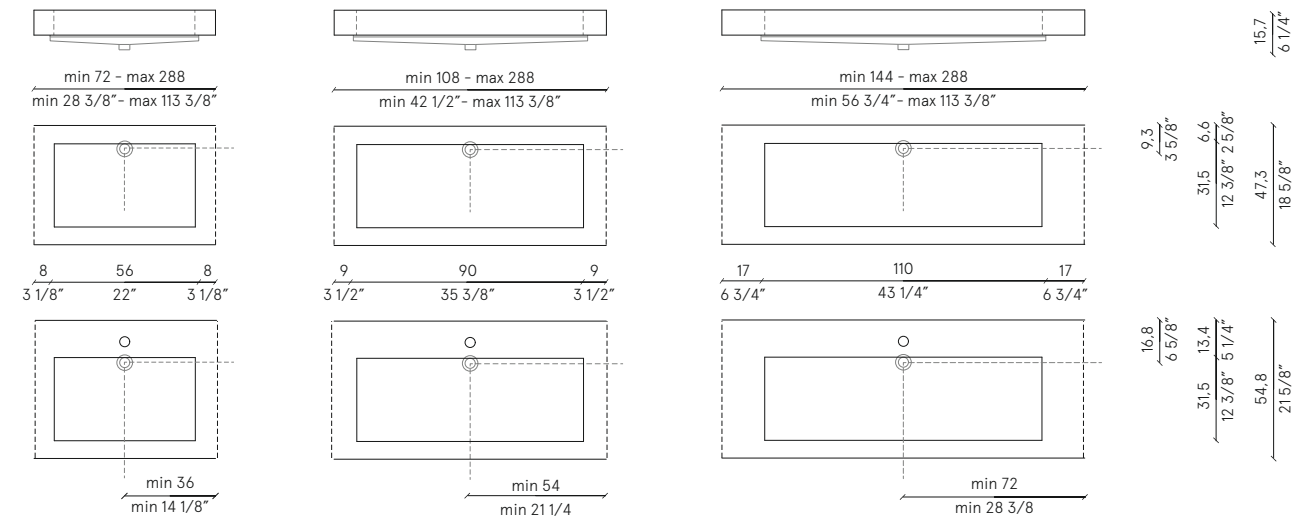

fniture | finishes | finitions | Oberflächen | отделки
sintetici | compounds | synthétiques | Kunststoff | соединений



due vasche | two basins | deux vasques | zwei Becken | два раковины
L top | W top | L plan | B Platte | Ш столешница
Next 56 + Next 56 = min 144 cm | 56 3/4"
Next 90 + Next 90 = min 180 cm | 70 7/8"
Next 110 + Next 110 = min 288 cm | 113 3/8"

top | plan | Platte | столешница
sp. | th. | sp. | Di. | тол.
10 / 3 7/8"

NEXT

SIT ON TOP



NEXT 10

SIT ON TOP



Next 56 | Next 90 | Next 110

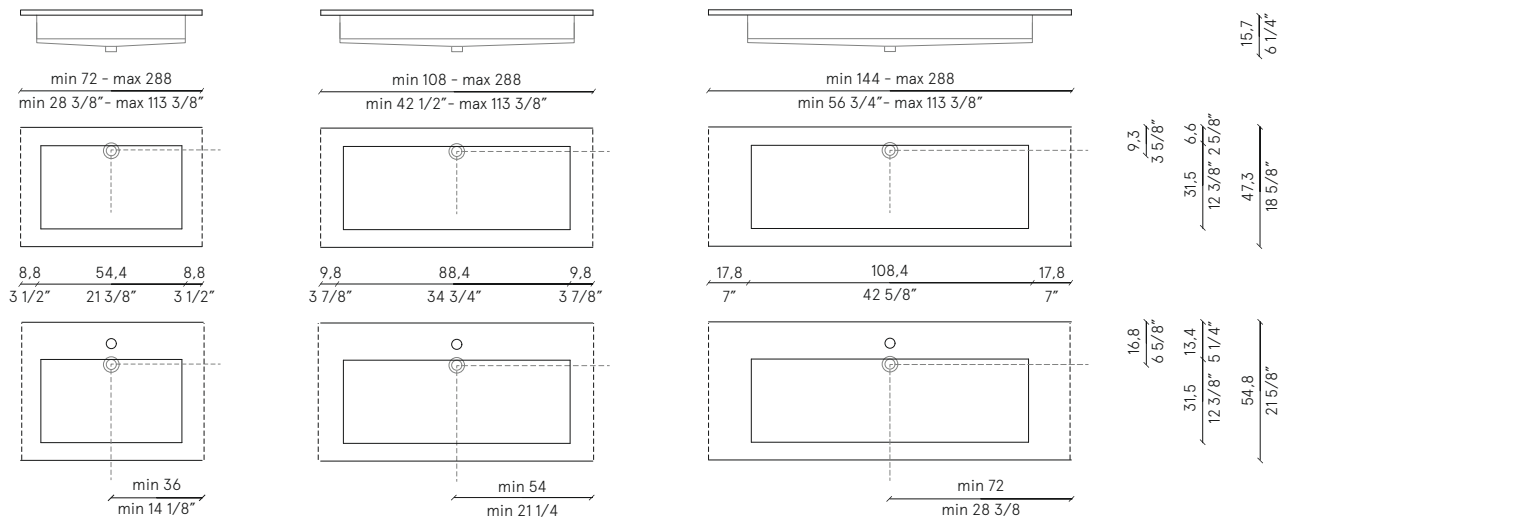

finiture | finishes | finitions | Oberflächen | отделки
marmi opachi | matt marbles | marbres mates | Marmor Matt | матовые мраморы

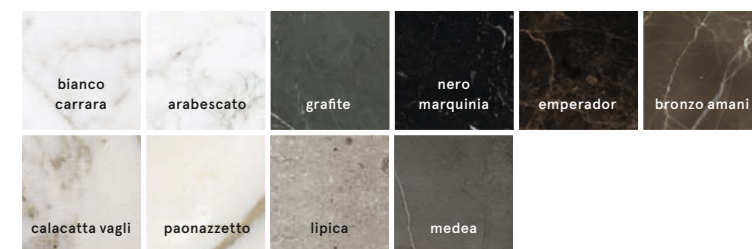

due vasche | two basins | deux vasques | zwei Becken | два раковины | top | plan | Platte | столешница
sp. | th. | sp. | Di. | тол.



Next 56 | Next 90 | Next 110

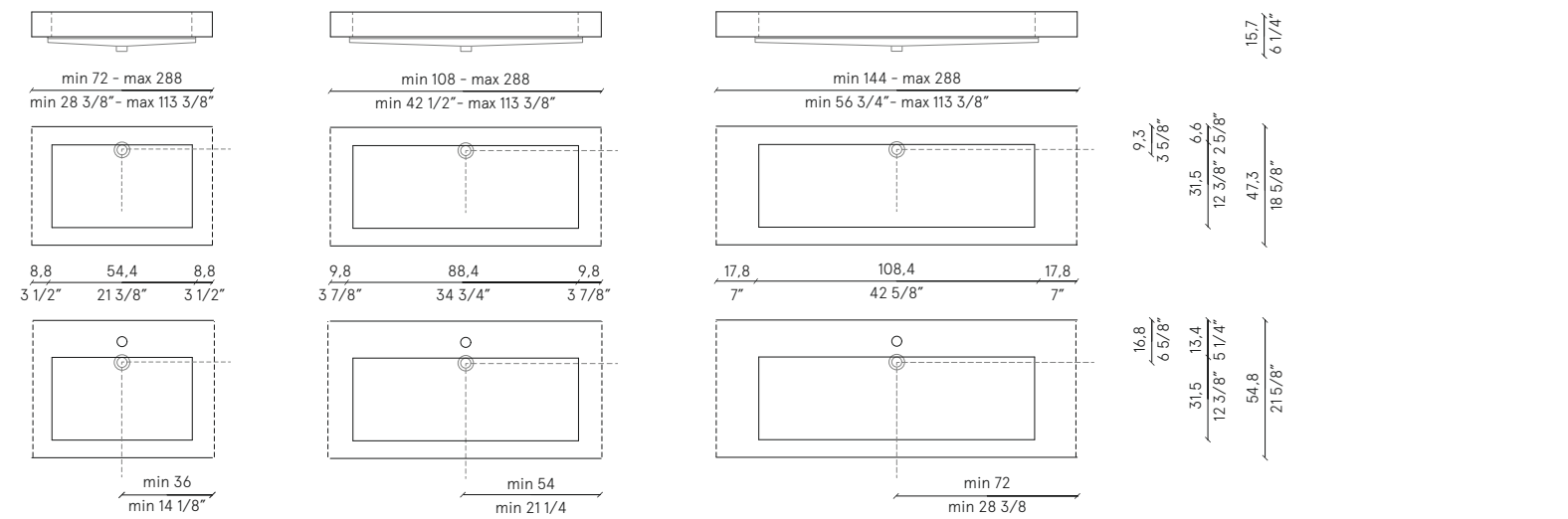

finiture | finishes | finitions | Oberflächen | отделки
marmi opachi | matt marbles | marbres mates | Marmor Matt | матовые мраморы

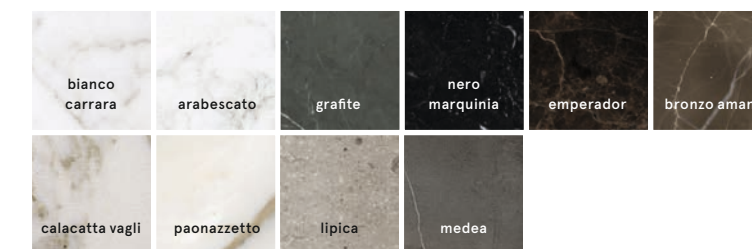

due vasche | two basins | deux vasques | zwei Becken | два раковины | top | plan | Platte | столешница
sp. | th. | sp. | Di. | тол.



REAL

SIT ON TOP



Real 55

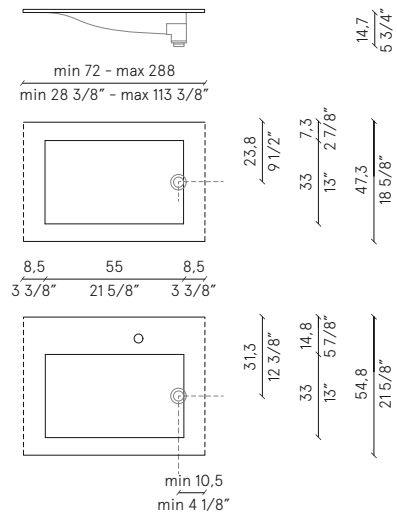

finiture | finishes | finitions | Oberflächen | отделки
 sintetici | compounds | synthétiques | Kunststoff | соединений

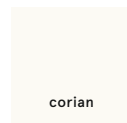

due vasche | two basins | deux vasques | zwei Becken | два раковины
 L top | W top | L plan | B Platte | Ш столешница
 Real 55 + Real 55 = min 144 cm | 56 3/4"

top | plan | Platte | столешница
 sp. | th. | sp. | Di. | тол.
 SINTESI 1,2 / 1/2"
 PURO 1,9 / 3/4"

REAL

SIT ON TOP



Real 110

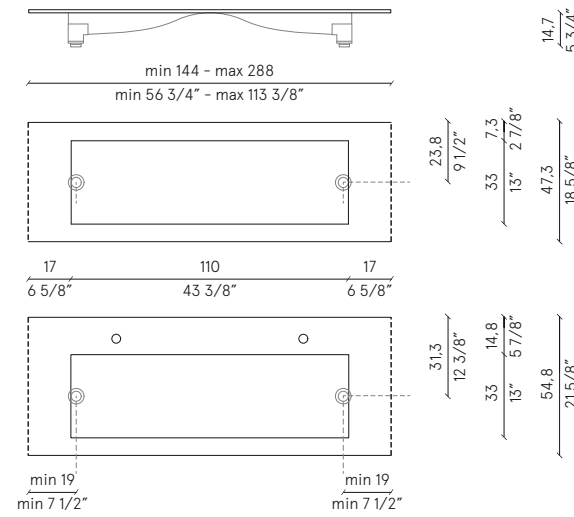

finiture | finishes | finitions | Oberflächen | отделки
 sintetici | compounds | synthétiques | Kunststoff | соединений

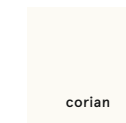

top | plan | Platte | столешница
 sp. | th. | sp. | Di. | тол.
 SINTESI 1,2 / 1/2"
 PURO 1,9 / 3/4"

BRILLIANT

SIT ON TOP



Brilliant O1

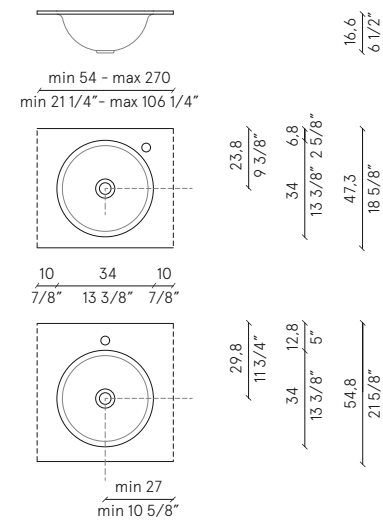

finiture | finishes | finitions | Oberflächen | отделки
vetri | glasses | verres | Gläser | стекла

bianco	corda	castoro	nero	vinaccia	peonia
riso	argilla	creta	grafite	malva	fuoco
mandoria	agata	fango	pietra	turchese	corallo
cipria	origano	bosco	zaffiro	ottanio	zafferano
ghiala	muschio	pistacchio			

due vasche | two basins | deux vasques | zwei Becken | два раковины
L top | W top | L plan | B Platte | Ш столешница

Brilliant O1 + Brilliant O1 = min 108 cm | 42 1/2"

top | plan | Platte | столешница
sp. | th. | sp. | Di. | тол.

SINTESI	1,2 3/4"
PURO	1,9 3/4"

BRILLIANT

SIT ON TOP



Brilliant O2 | Brilliant O3

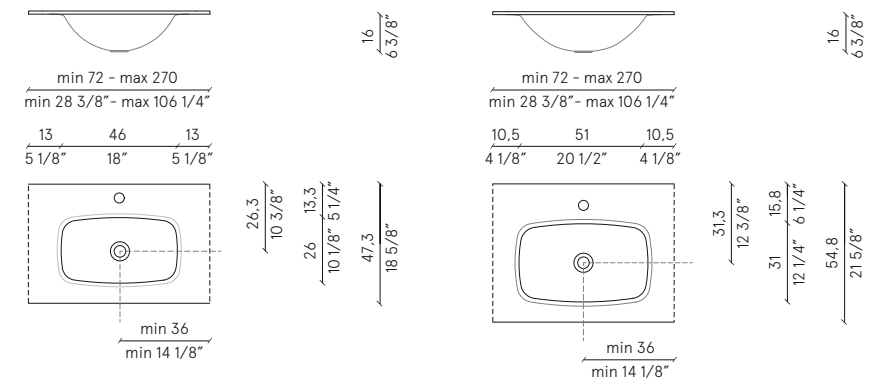

finiture | finishes | finitions | Oberflächen | отделки
vetri | glasses | verres | Gläser | стекла

bianco	corda	castoro	nero	vinaccia	peonia
riso	argilla	creta	grafite	malva	fuoco
mandoria	agata	fango	pietra	turchese	corallo
cipria	origano	bosco	zaffiro	ottanio	zafferano
ghiala	muschio	pistacchio			

due vasche | two basins | deux vasques | zwei Becken | два раковины
L top | W top | L plan | B Platte | Ш столешница

Brilliant O2 + Brilliant O2 = min 144 cm | 56 3/4"
Brilliant O3 + Brilliant O3 = min 144 cm | 56 3/4"

top | plan | Platte | столешница
sp. | th. | sp. | Di. | тол.

SINTESI	1,2 3/4"
PURO	1,9 3/4"

WHOLE

SIT ON TOP



WHOLE

SIT ON TOP



Whole 72 | Whole 90 | Whole 108

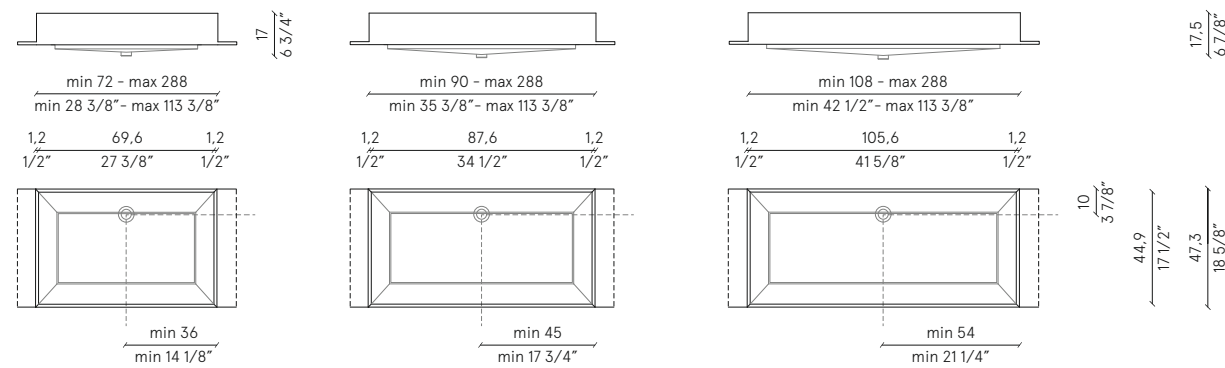

fniture | finishes | finitions | Oberflächen | отделки
 sintetici | compounds | synthétiques | Kunststoff | соединений



due vasche | two basins | deux vasques | zwei Becken | два раковины
 L top | W top | L plan | B Platte | Ш столешница
 Whole 72 + Whole 72 = min 144 cm | 56 3/4"
 Whole 90 + Whole 90 = min 180 cm | 70 7/8"
 Whole 108 + Whole 108 = min 216 cm | 85"

top | plan | Platte | столешница
 sp. | th. | sp. | Di. | тол.
 SINTESI 1,2 / 1/2"
 PURO 1,9 / 3/4"

Whole 72 | Whole 90 | Whole 108

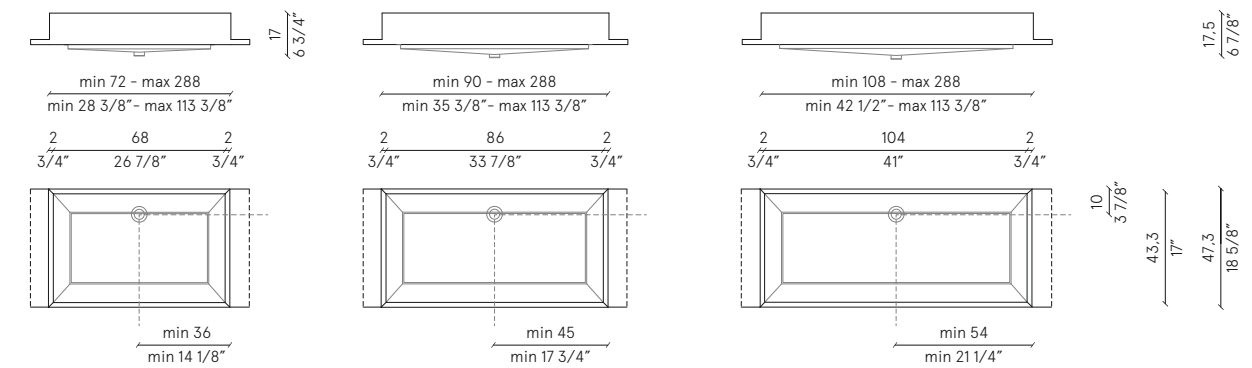

fniture | finishes | finitions | Oberflächen | отделки
 marmi opachi | matt marbles | marbres mates | Marmor Matt | матовые мраморы



top | plan | Platte | столешница
 sp. | th. | sp. | Di. | тол.
 SINTESI 2 / 3/4"
 PURO 1,9 / 3/4"

HEIGHT

SIT ON TOP



HEIGHT

SIT ON TOP



Height 72 | Height 90 | Height 108

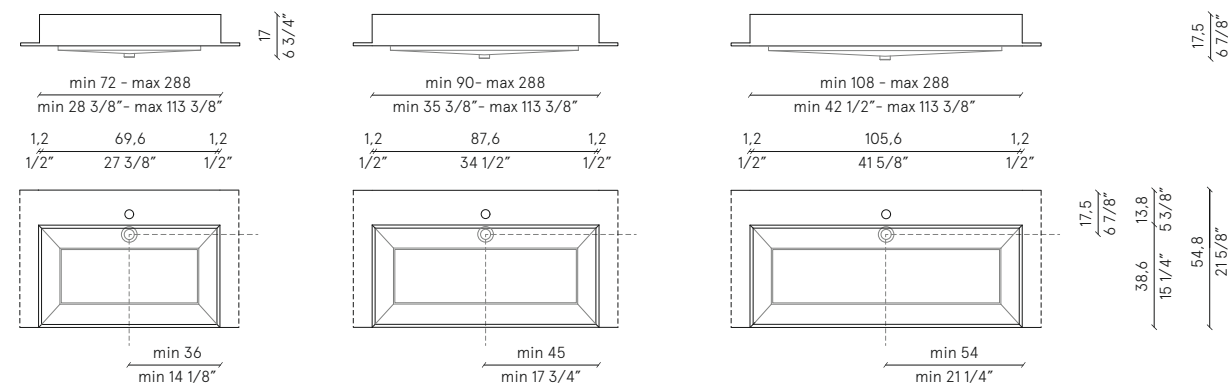

fniture | finishes | finitions | Oberflächen | отделки
sintetici | compounds | synthétiques | Kunststoff | соединений



due vasche | two basins | deux vasques | zwei Becken | два раковины
L top | W top | L plan | B Platte | Ш столешница
Height 72 + Height 72 = min 144 cm | 56 3/4"
Height 90 + Height 90 = min 180 cm | 70 7/8"
Height 108 + Height 108 = min 216 cm | 85"

top | plan | Platte | столешница
sp. | th. | sp. | Di. | тол.
SINTESI 1,2 / 1 1/2"
PURO 1,9 / 3/4"

Height 72 | Height 90 | Height 108

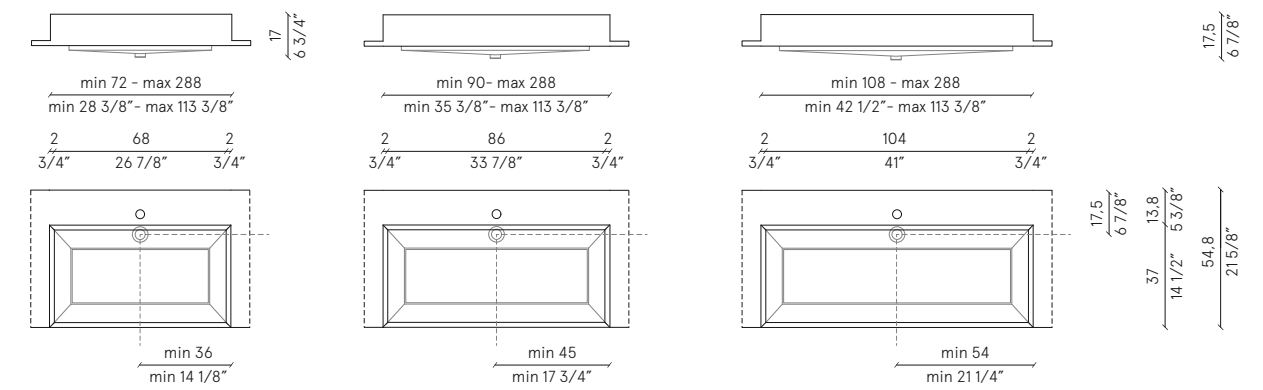

fniture | finishes | finitions | Oberflächen | отделки
marmi opachi | matt marbles | marbres mates | Marmor Matt | матовые мраморы

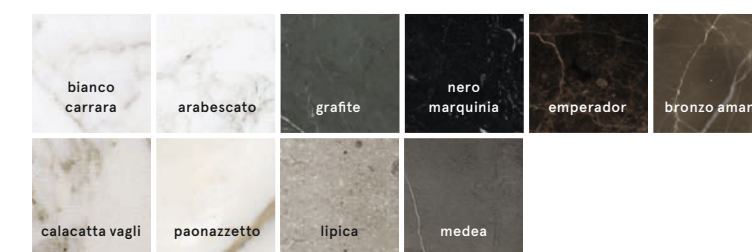

top | plan | Platte | столешница
sp. | th. | sp. | Di. | тол.
SINTESI 2 / 3/4"
PURO 1,9 / 3/4"



Stage 01 | Stage 02 | Stage 03 | Stage 04 | Stage 05 | Stage 06

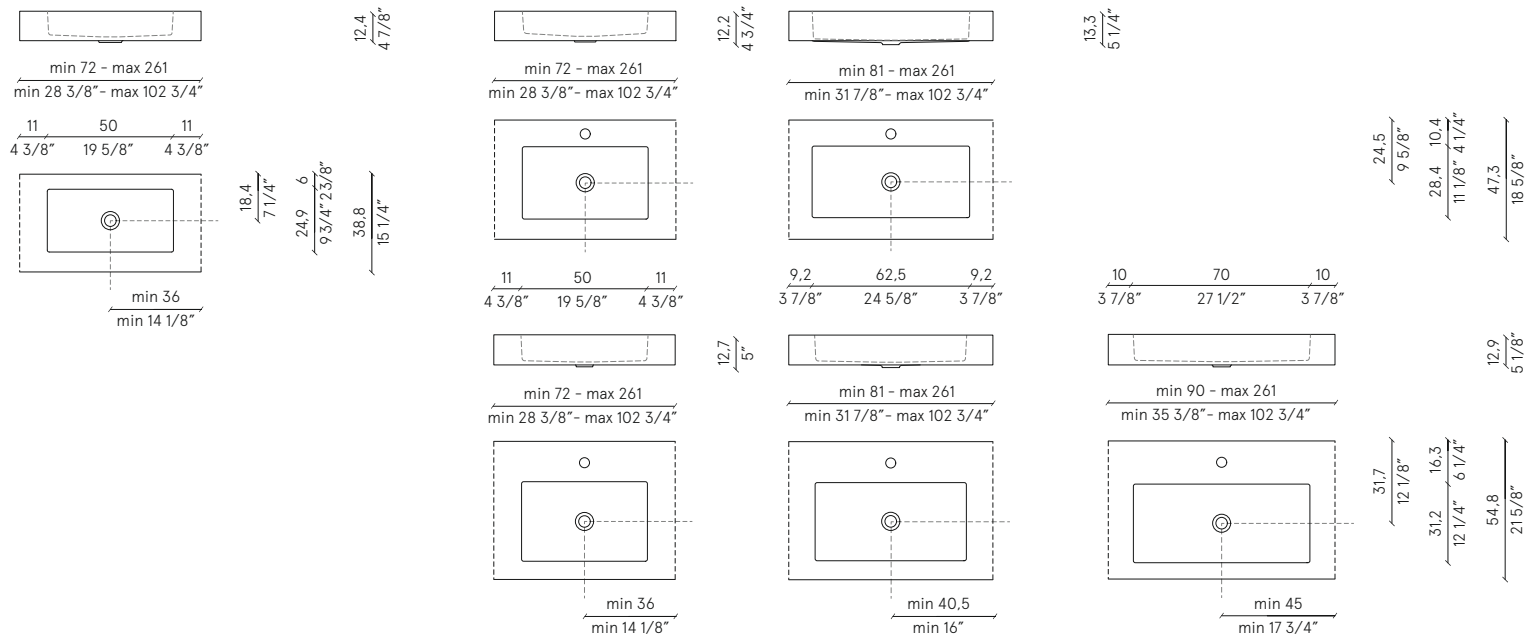

fniture | finishes | finitions | Oberflächen | отделки
 sintetici | compounds | synthétiques | Kunststoff | соединений



due vasche | two basins | deux vasques | zwei Becken | два раковины
 L top | W top | L plan | B Platte | Ш столешница

Stage 01 + Stage 01 = min 144 cm | 56 3/4"
 Stage 02 + Stage 02 = min 144 cm | 56 3/4"
 Stage 03 + Stage 03 = min 162 cm | 63 3/4"
 Stage 04 + Stage 04 = min 144 cm | 56 3/4"
 Stage 05 + Stage 05 = min 162 cm | 63 3/4"
 Stage 06 + Stage 06 = min 180 cm | 70 7/8"



Neat 01 | Neat 02

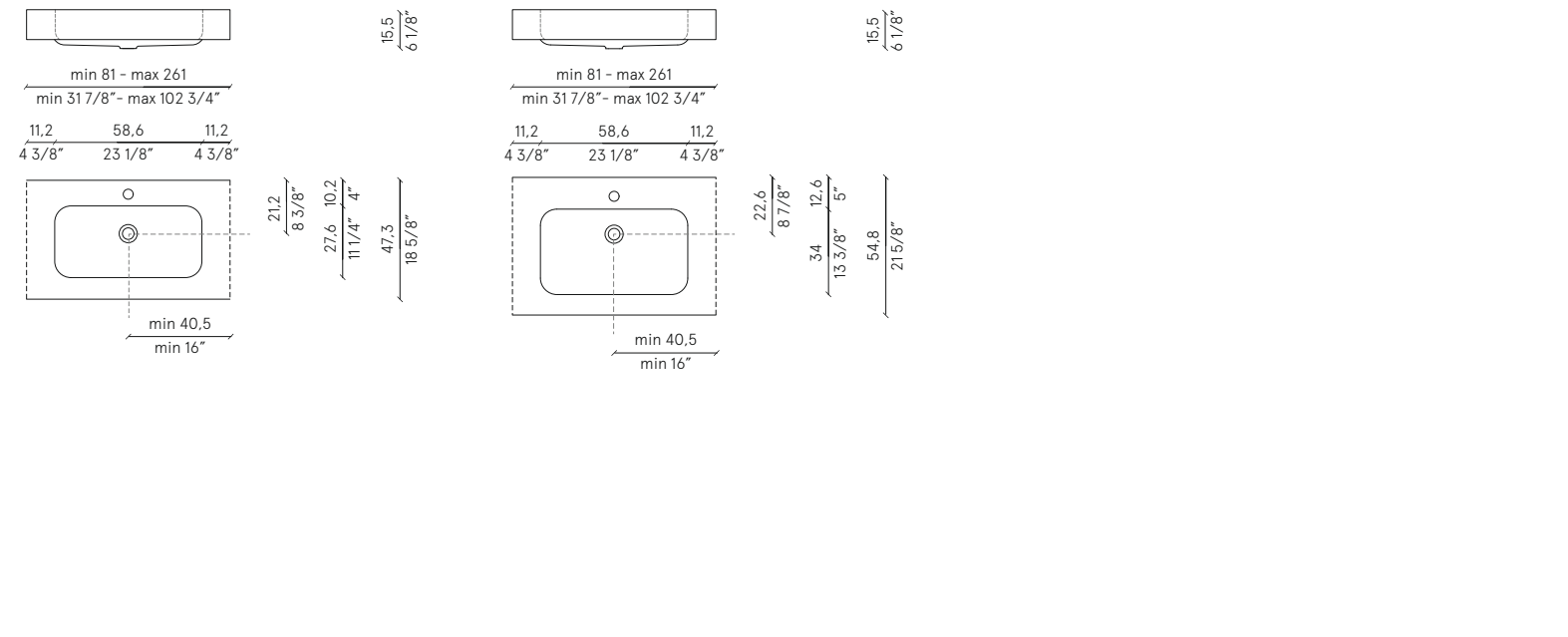

fniture | finishes | finitions | Oberflächen | отделки
 sintetici | compounds | synthétiques | Kunststoff | соединений



due vasche | two basins | deux vasques | zwei Becken | два раковины
 L top | W top | L plan | B Platte | Ш столешница

Neat 01 + Neat 01 = min 162 cm | 63 3/4"
 Neat 02 + Neat 02 = min 162 cm | 63 3/4"

ROUND 12

SUSPENDED TOP



Round 01 | Round 02

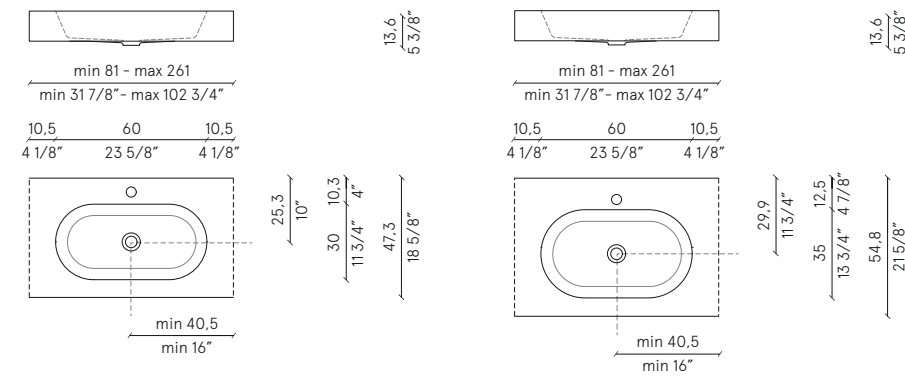

finiture | finishes | finitions | Oberflächen | отделки
 sintetici | compounds | synthétiques | Kunststoff | соединений



due vasche | two basins | deux vasques | zwei Becken | два раковины
 L top | W top | L plan | B Platte | Ш столешница
 top | plan | Platte | столешница
 sp. | th. | sp. | Di. | тол.

Round 01 + Round 01 = min 162 cm | 63 3/4"
 Round 02 + Round 02 = min 162 cm | 63 3/4"

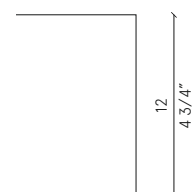

SPAN 12

SUSPENDED TOP



Span 01 | Span 02 | Span 03 | Span 04

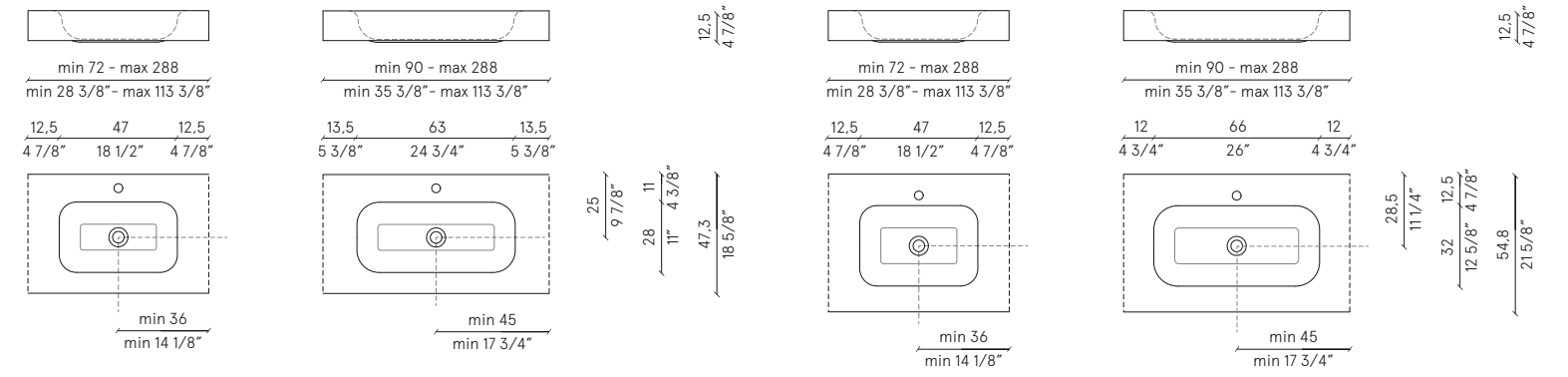

finiture | finishes | finitions | Oberflächen | отделки
 sintetici | compounds | synthétiques | Kunststoff | соединений



due vasche | two basins | deux vasques | zwei Becken | два раковины
 L top | W top | L plan | B Platte | Ш столешница
 top | plan | Platte | столешница
 sp. | th. | sp. | Di. | тол.

Span 01 + Span 01 = min 144 cm | 56 3/4"
 Span 02 + Span 02 = min 180 cm | 70 7/8"
 Span 03 + Span 03 = min 144 cm | 56 3/4"
 Span 04 + Span 04 = min 180 cm | 70 7/8"

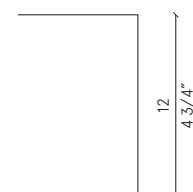

LAND 12

SUSPENDED TOP



Land 01 | Land 02

con piano copripiletta | with drain cover | avec plan cache-bond | mit Abfluss Abdeckung | плоская крышка слива

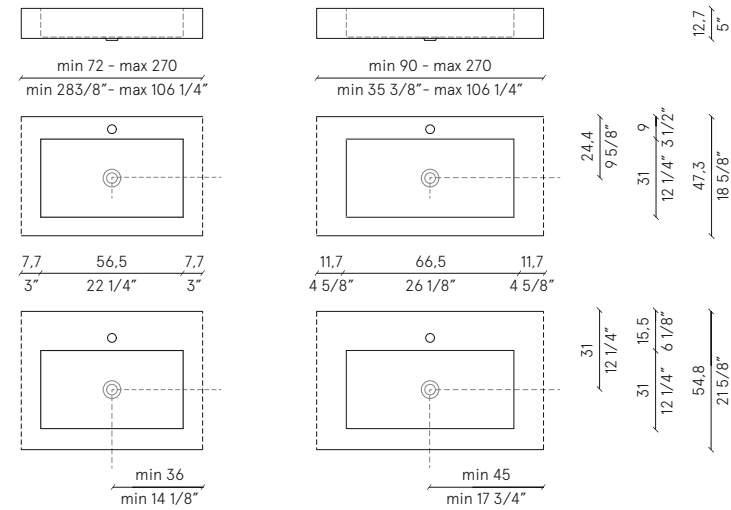

finiture | finishes | finitions | Oberflächen | отделки
argille | clays | argiles | Lehm | глины



due vasche | two basins | deux vasques | zwei Becken | два раковины
L top | W top | L plan | B Platte | Ш столешница

Land 01 + Land 01 = min 144 cm | 56 3/4"
Land 02 + Land 02 = min 180 cm | 70 7/8"

top | plan | Platte | столешница
sp. | th. | sp. | Di. | тол.

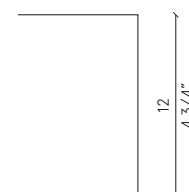

STILL 12

SUSPENDED TOP



Still 01 | Still 02 | Still 03 | Still 04

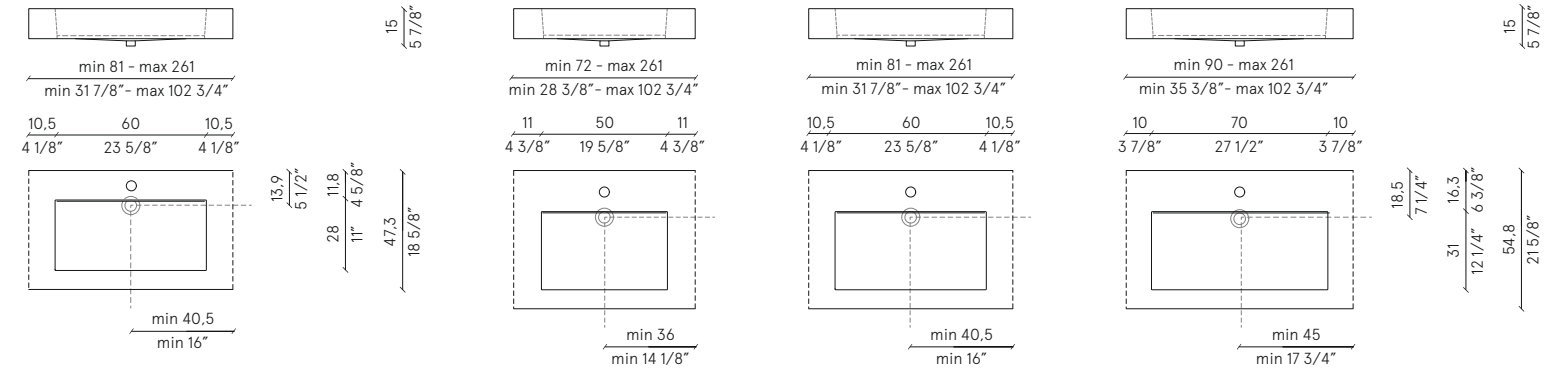

finiture | finishes | finitions | Oberflächen | отделки
sintetici | compounds | synthétiques | Kunststoff | соединений



due vasche | two basins | deux vasques | zwei Becken | два раковины
L top | W top | L plan | B Platte | Ш столешница

Still 01 + Still 01 = min 162 cm | 63 3/4"
Still 02 + Still 02 = min 144 cm | 56 3/4"
Still 03 + Still 03 = min 162 cm | 63 3/4"
Still 04 + Still 04 = min 180 cm | 70 7/8"

top | plan | Platte | столешница
sp. | th. | sp. | Di. | тол.

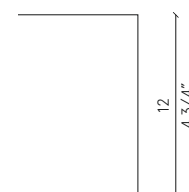



Next 56 | Next 90 | Next 108

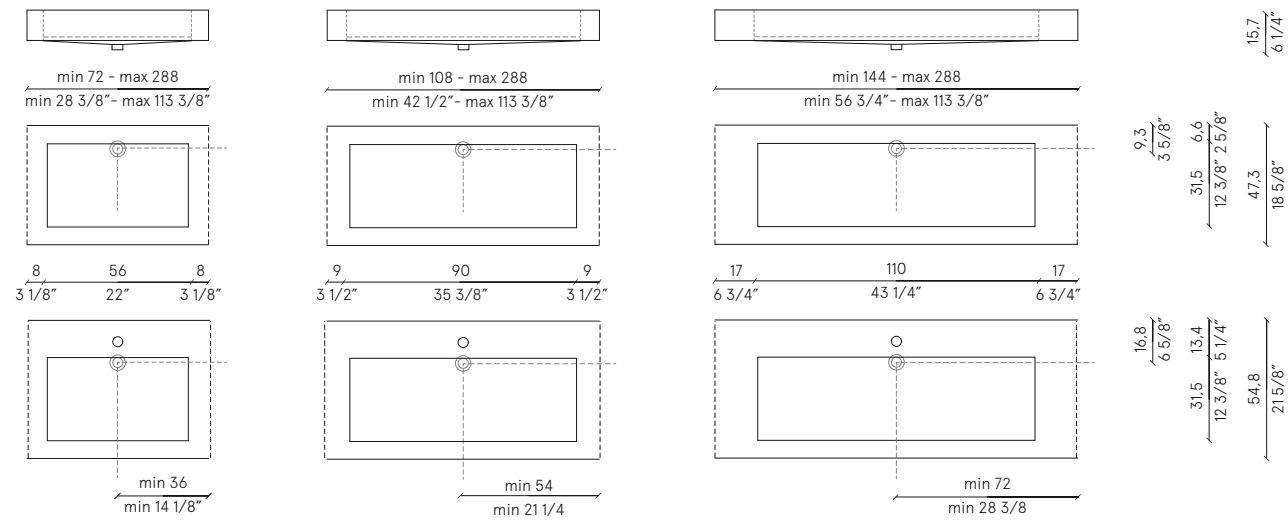

finiture | finishes | finitions | Oberflächen | отделки
 sintetici | compounds | synthétiques | Kunststoff | соединений



due vasche | two basins | deux vasques | zwei Becken | два раковины | top | plan | Platte | столешница
 sp. | th. | sp. | Di. | тол.

Next 56 + Next 56 = min 144 cm | 56 3/4"
 Next 90 + Next 90 = min 180 cm | 70 7/8"
 Next 110 + Next 110 = min 288 cm | 113 3/8"

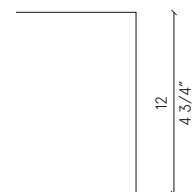

Next 56 | Next 90 | Next 108

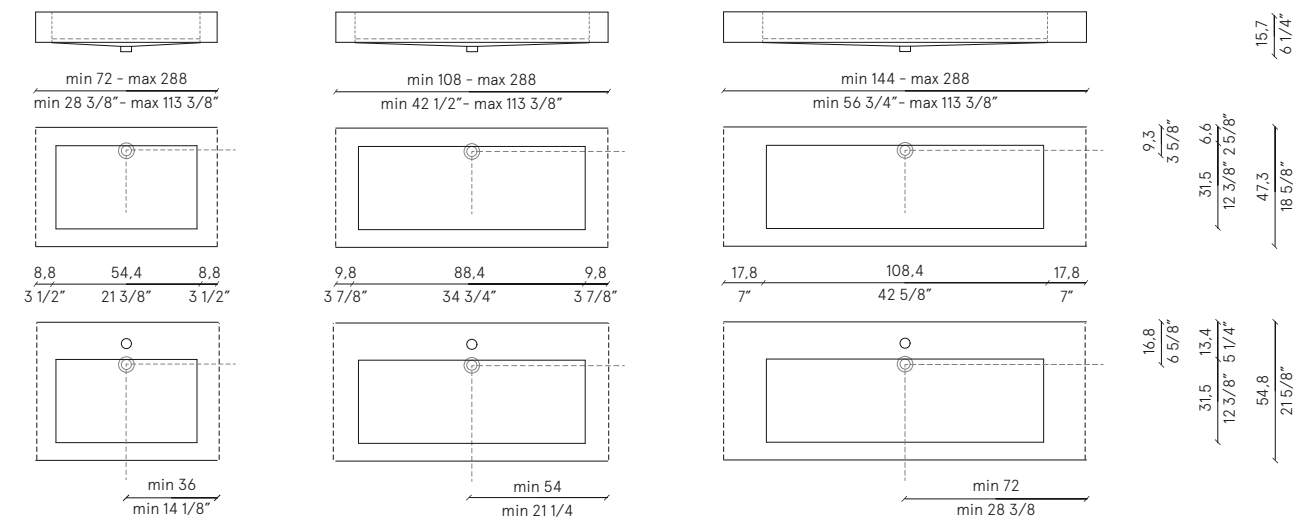

finiture | finishes | finitions | Oberflächen | отделки
 marmi opachi | matt marbles | marbres mates | Marmor Matt | матовые мраморы

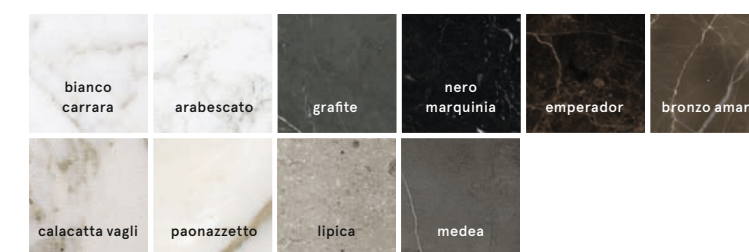

due vasche | two basins | deux vasques | zwei Becken | два раковины | top | plan | Platte | столешница
 sp. | th. | sp. | Di. | тол.

Next 56 + Next 56 = min 144 cm | 56 3/4"
 Next 90 + Next 90 = min 180 cm | 70 7/8"
 Next 110 + Next 110 = min 288 cm | 113 3/8"

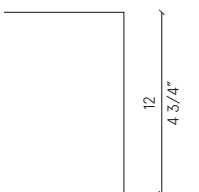

STRICT

SUSPENDED TOP



STRICT

SUSPENDED TOP



Strict 54 | Strict 88 | Strict 140

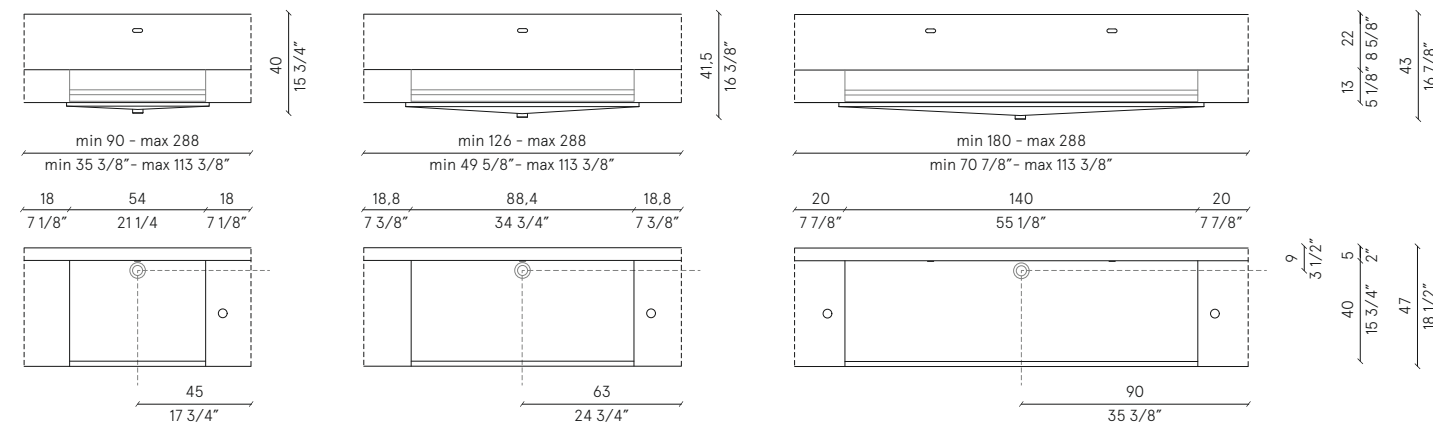

fniture | finishes | finitions | Oberflächen | отделка
 sintetici | compounds | synthétiques | Kunststoff | соединений



top | plan | Platte | столешница
 sp. | th. | sp. | Di. | тол.

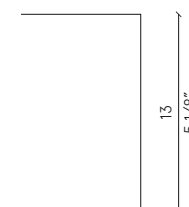

Strict 54 | Strict 88 | Strict 140

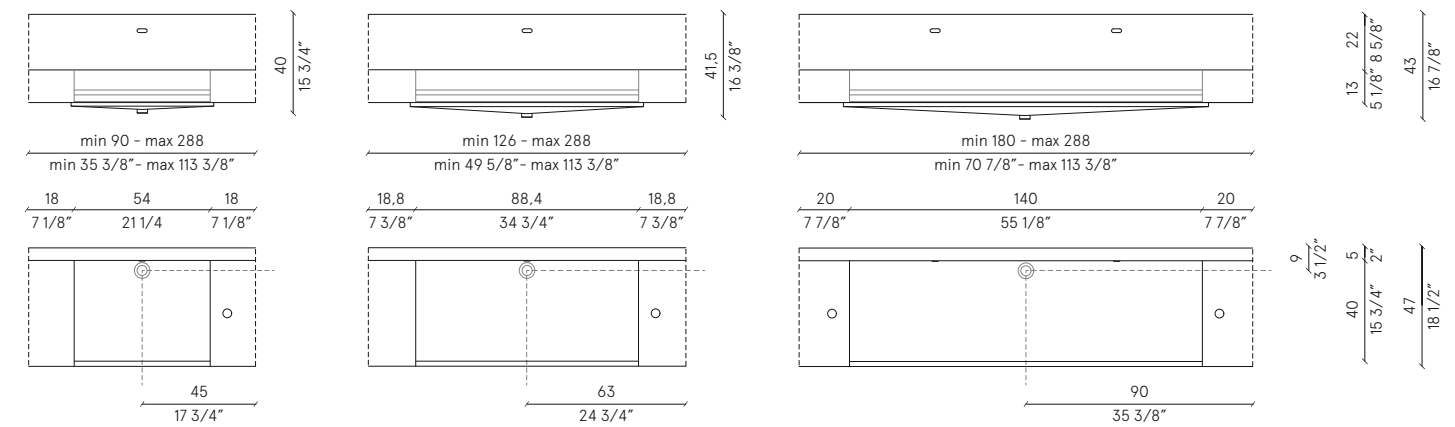

fniture | finishes | finitions | Oberflächen | отделка
 marmi opachi | matt marbles | marbres mates | Marmor Matt | матовые мраморы

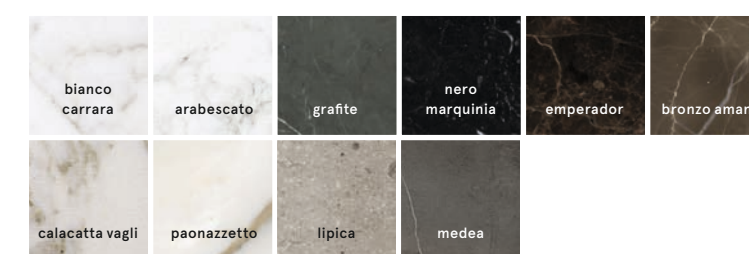

top | plan | Platte | столешница
 sp. | th. | sp. | Di. | тол.

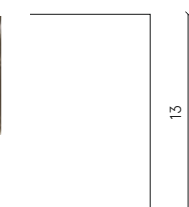

UNIQUE

SUSPENDED TOP



Unique 54 | Unique 216

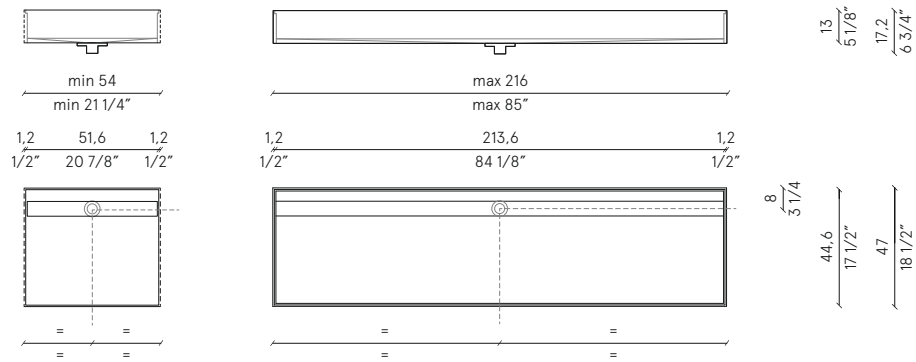

fniture | finishes | finitions | Oberflächen | отделки
 sintetici | compounds | synthétiques | Kunststoff | соединений



top | plan | Platte | столешница
 sp. | th. | sp. | Di. | тол.

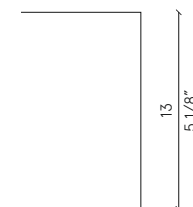

Firmano l'ambiente bagno con la propria presenza, soprattutto nelle versioni free-standing; si integrano perfettamente nell'architettura dello spazio e nel gioco sapiente dei volumi quando vengono incassate. Le vasche Noorth rappresentano una proposta completa per forme e tipologie, e prevedono soluzioni esclusive come l'illuminazione che amplifica l'atmosfera e le pedane che incassano la vasca collocandola al centro della scena. Concepito come elemento tecnico, lo spazio doccia Noorth, si inserisce con naturalezza in una logica compositiva integrata grazie alle soluzioni d'appoggio o da incasso.

They complete the bathroom decor with their presence, especially in the freestanding versions; they are perfectly integrated into the layout of the space and the clever play of volumes when built in. Noorth bathtubs represent an exhaustive furnishing proposal in terms of shapes and types, and provide unique solutions such as lighting to enhance the atmosphere and platforms to inset the bathtub so as to place it boldly center stage. Originally conceived as a technical element, the Noorth shower area fits effortlessly into an integrated compositional logic thanks to numerous built-in or sit-on solutions.

Les baignoires Noorth, en particulier en version autoportante, subliment les salles de bain par leur présence. Encastrées, elles s'intègrent à la perfection dans l'architecture de l'espace et dans le jeu savant des volumes. Solutions complètes en termes de types et de formes, les baignoires Noorth incluent des systèmes haut de gamme comme un éclairage qui agrandit l'espace ou des socles qui rehaussent la baignoire en la plaçant en plein cœur de la scène. Conçue en tant qu'élément technique, la zone douche Noorth s'inscrit tout naturellement dans une logique de composition intégrée grâce aux solutions à poser ou à encastrer.

Diese sowohl in der Ausführung freistehend als auch eingebaut nutzbaren Badewannen fügen sich auf perfekte Weise als Bestandteile eines Wechselspiels von Formen in die Raumgestaltung des Bades ein. Die Badewannen Noorth bilden eine in Form und Typologie vollumfassende Einheit und bieten einzigartige Lösungen an, wie zum Beispiel Beleuchtungen, die für eine besondere Stimmung sorgen, oder Auflagen, die die Badewanne anheben und sie zur Hauptakteurin der Raumgestaltung machen. Als technischer Bestandteil des Bades konzipiert fügt sich die Dusche Noorth dank der Möglichkeit einer aufliegenden oder eingebauten Fertigung natürlich in die gestalterische Einheit des Raumes ein.

Они определяют стиль ванной комнаты, особенно в отдельно установленных вариантах; ванны прекрасно вписываются в архитектуру пространства, при встроенной установке создавая интересную игру объемов. Ванны Noorth представляют собой комплексные решения, включающие разнообразные формы и типы, предусматривая эксклюзивные решения, такие, как освещение, расширяющее пространство, и платформы, приподнимающие ванны над полом и концентрирующие на них внимание. Задуманная как технический элемент, душевая кабина Noorth естественно вписывается в логику всего помещения, благодаря наличию как встроенных так и устанавливаемых на пол решений. настенных или установленных на несущую поверхность вариантов, смесители Noorth могут иметь отделку в виде полированной или сатинированной нержавеющей стали и хромированной поверхности.



Oval

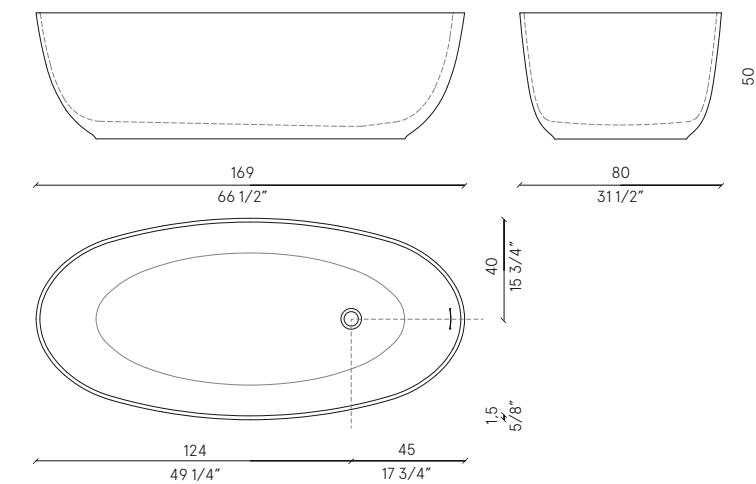

finiture | finishes | finitions | Oberflächen | отделки
 sintetici | compounds | synthétiques | Kunststoff | соединений



BRICK

FREE STANDING



SLASH

FREE STANDING



Brick

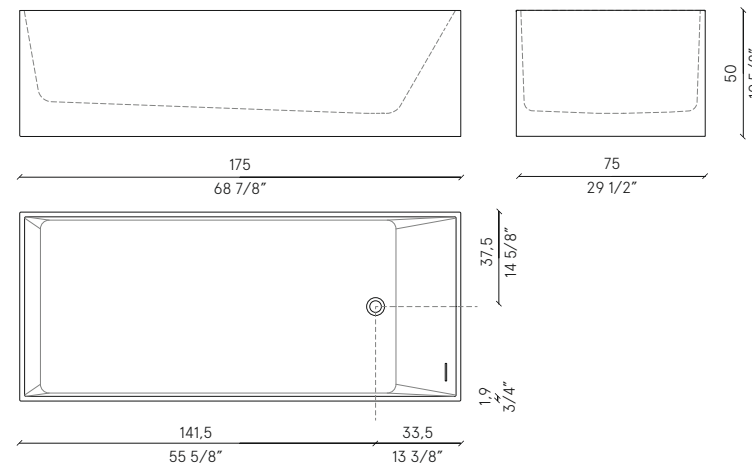

fniture | fnishes | fnitions | Oberflächen | отделки
sintetici | compounds | synthétiques | Kunststoff | соединений

milltek

Slash

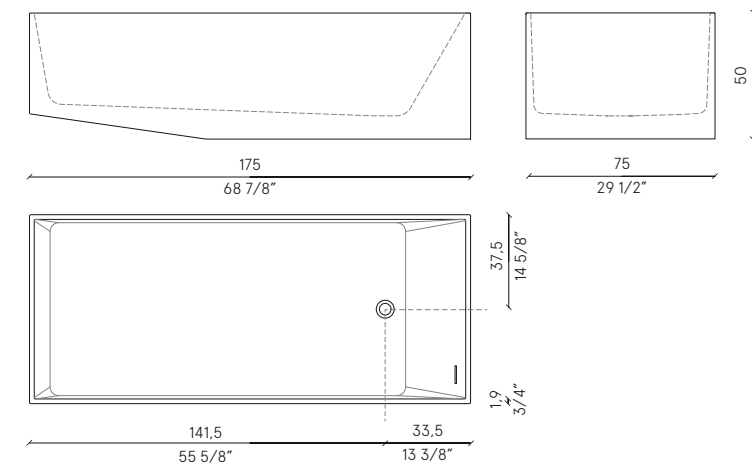

fniture | fnishes | fnitions | Oberflächen | отделки
sintetici | compounds | synthétiques | Kunststoff | соединений

milltek

RING

FREE STANDING



Ring

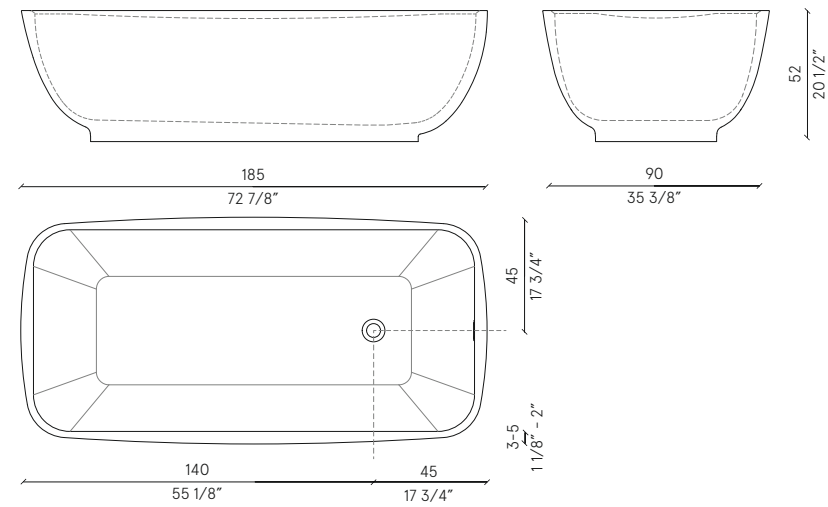

fniture | finishes | finitions | Oberflächen | отделки
 sintetici | compounds | synthétiques | Kunststoff | соединений

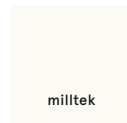

SKA 50

FREE STANDING



Ska 50

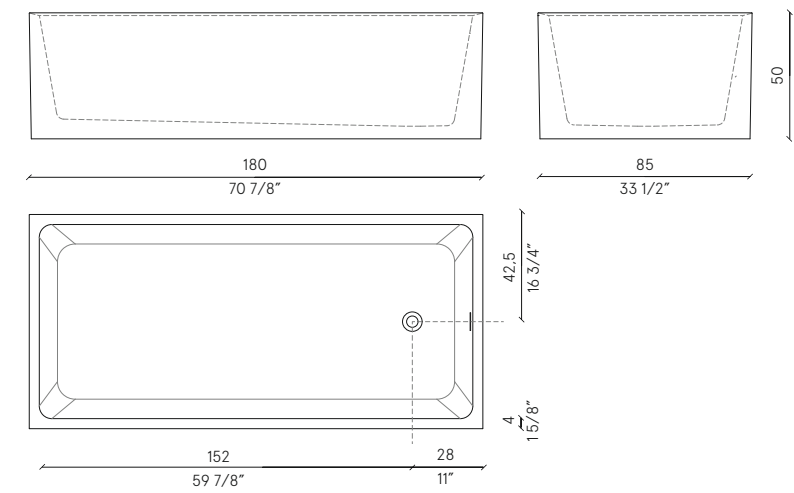

fniture | finishes | finitions | Oberflächen | отделки
 sintetici | compounds | synthétiques | Kunststoff | соединений

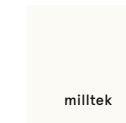

SKA 35

SEMI INSET



Ska 35

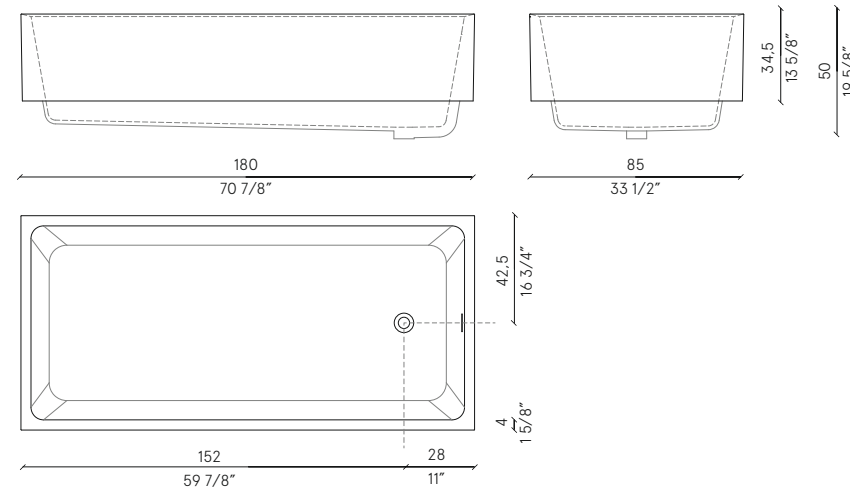

finiture | finishes | finitions | Oberflächen | отделки
 sintetici | compounds | synthétiques | Kunststoff | соединений

milltek

SKA 25

SEMI INSET



Ska 25

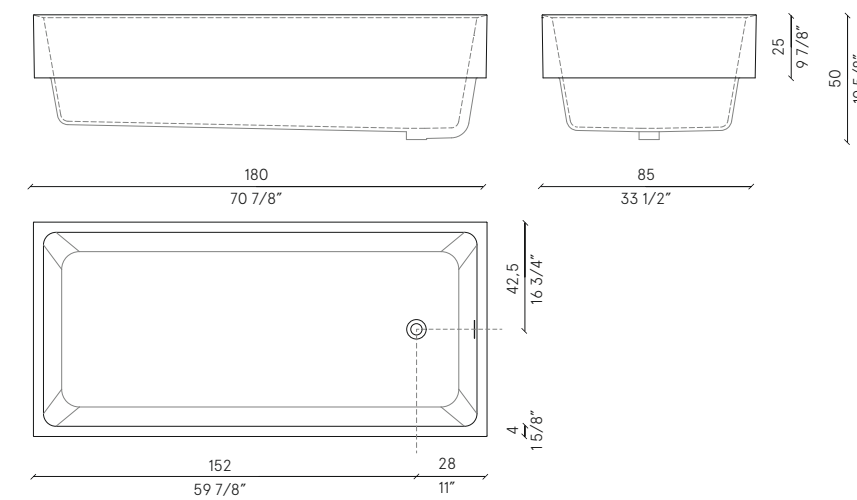

finiture | finishes | finitions | Oberflächen | отделки
 sintetici | compounds | synthétiques | Kunststoff | соединений

milltek

STYLING R01

INSET



Styling R01

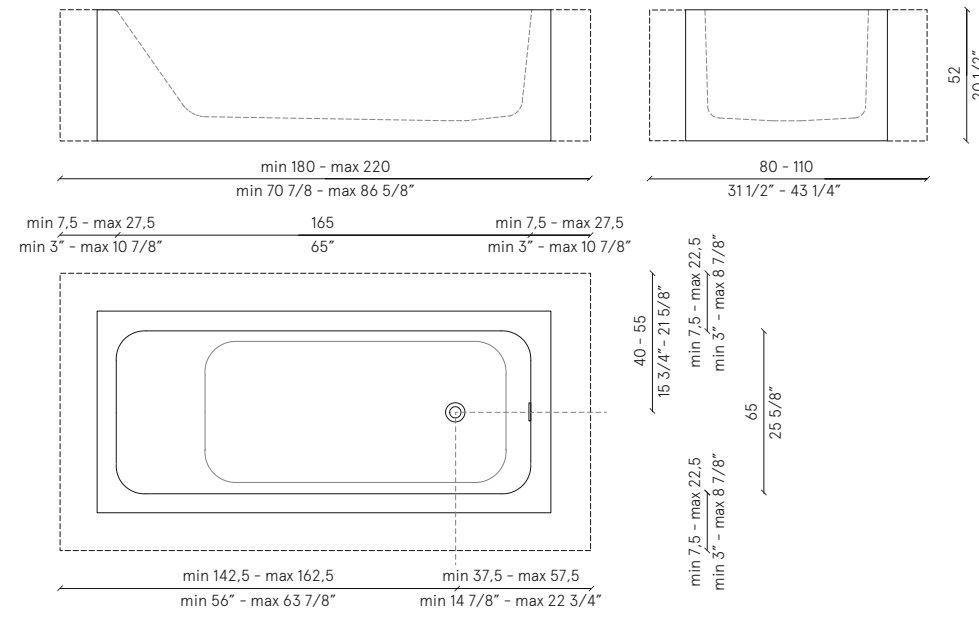

finiture | finishes | finitions | Oberflächen | отделки
 sintetici | compounds | synthétiques | Kunststoff | соединений

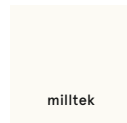

STYLING E01

INSET



Styling E01

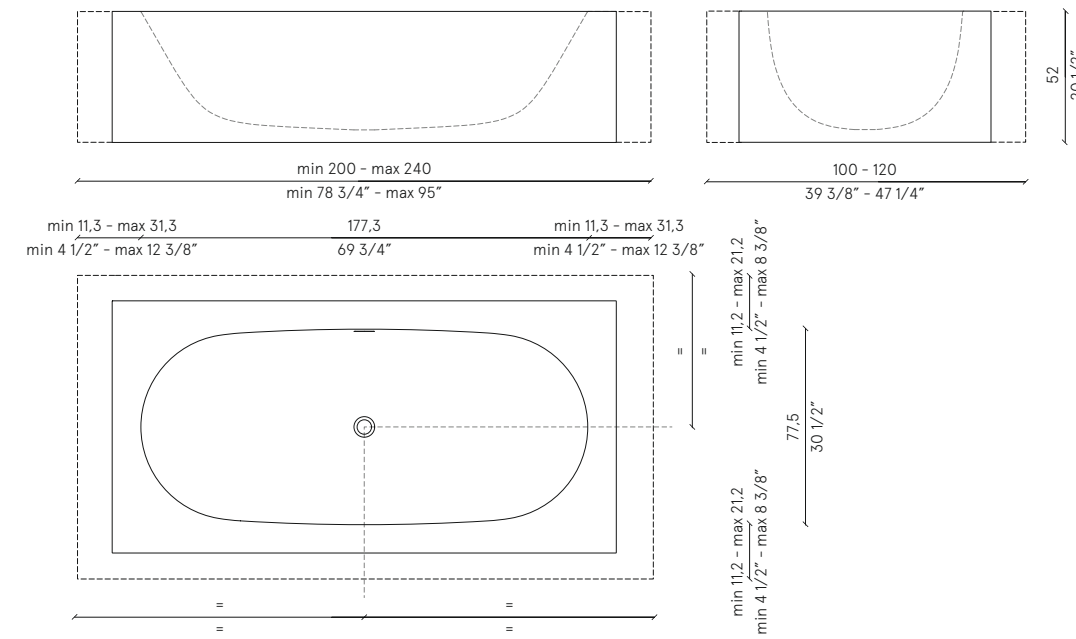

finiture | finishes | finitions | Oberflächen | отделки
 sintetici | compounds | synthétiques | Kunststoff | соединений

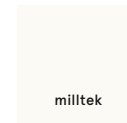

SHARP H3

INSET OR SEMI INSET



Sharp H3

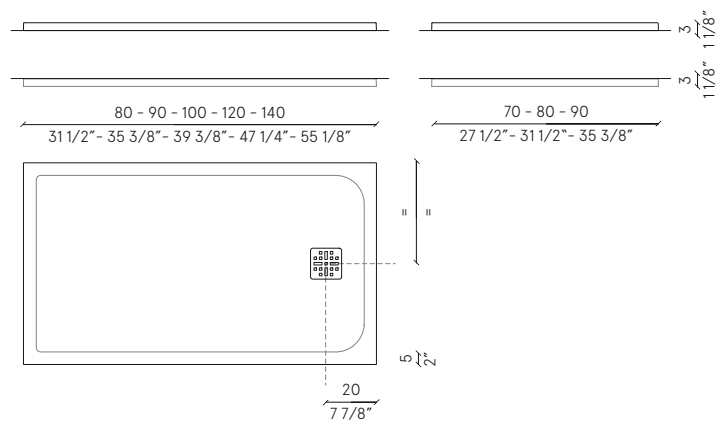

modularità | modularity | modularité | Modularität | модульность
misura fissa | fixed measurement | mesure fixe | Festes Maß | фиксированная мера

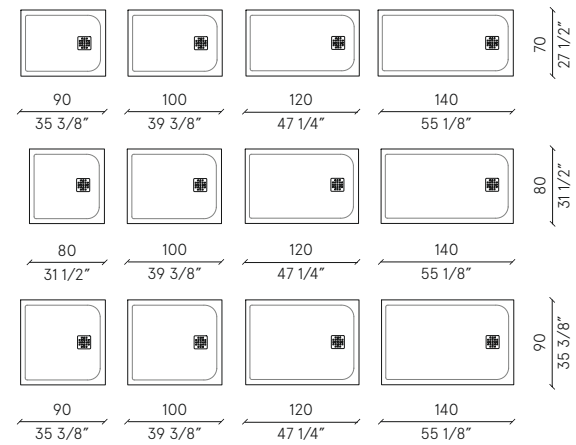

fniture | finishes | finitions | Oberflächen | отделки

sintetici | compounds | synthétiques | Kunststoff | соединений

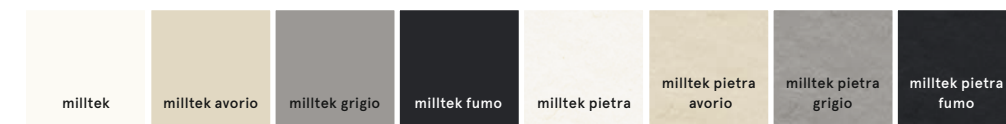

SHARP H3

INSET OR SEMI INSET



Sharp H3

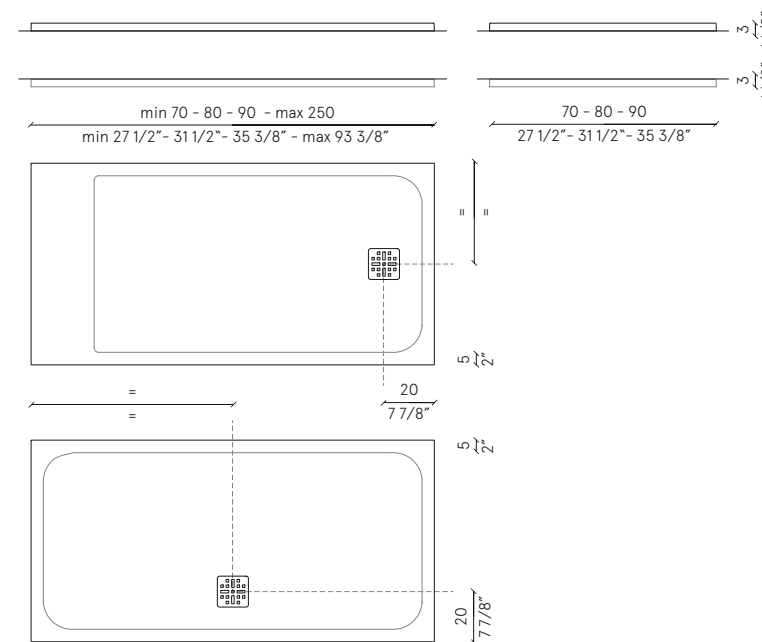

modularità | modularity | modularité | Modularität | модульность
su misura | customised | sur mesure | Maßgearbeitet | фиксированная мера

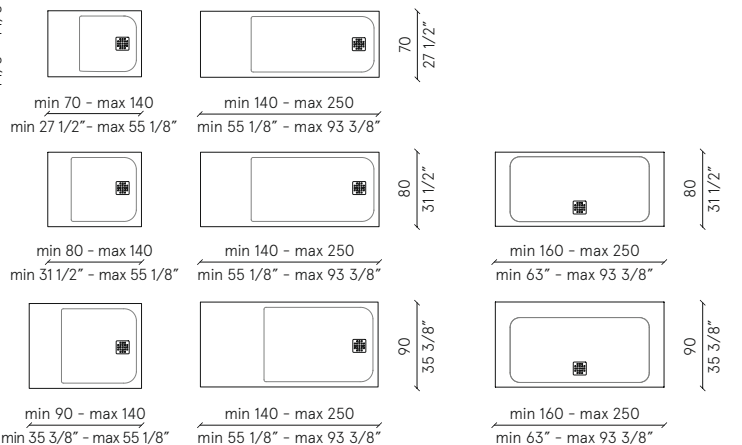

fniture | finishes | finitions | Oberflächen | отделки

sintetici | compounds | synthétiques | Kunststoff | соединений

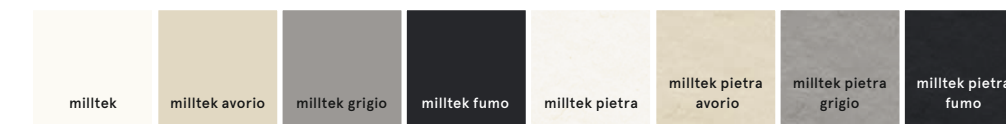

LINE

INSET OR SEMI INSET



Line H5

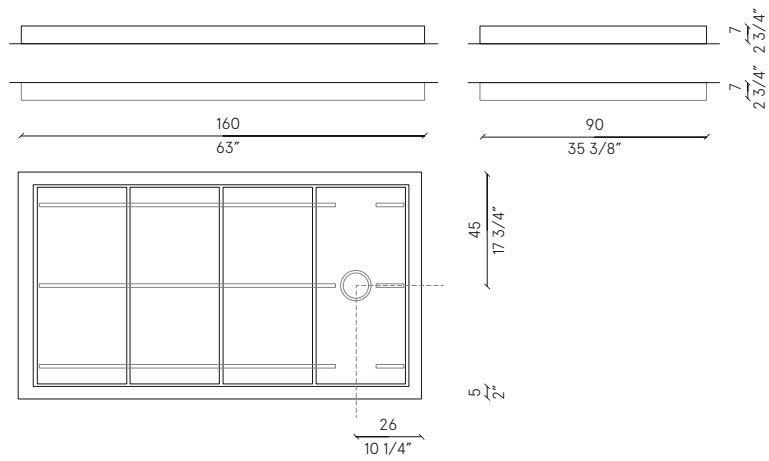

modularità | modularity | modularité | Modularität | модульность

su misura | customised | sur mesure | Maßgearbeitet | фиксированная мера

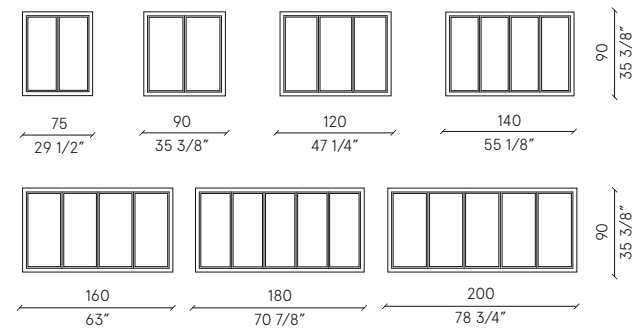

finiture | finishes | finitions | Oberflächen | отделки
 sintetici | compounds | synthétiques | Kunststoff | соединений

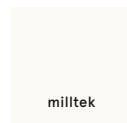

Fondamentali per completare il progetto dell'area bagno, dialogano con gli elementi sui quali sono installati per fornire un'immagine coordinata ma anche per assicurare funzionalità e soddisfare le richieste specifiche. Presenza discreta ed essenziali, i rubinetti Noorth si declinano nelle due collezioni Flow e H2O e grazie a un'ampia gamma di modelli soddisfano qualsiasi esigenza di installazione. Pensati per lavabi, vasche e sanitari, nelle versioni da piano, terra o parete, i rubinetti Noorth sono disponibili nelle finiture acciaio inox lucido, inox satinato e cromo.

Essential for adding finishing touches to the bathroom furnishing project, interacting with the fittings onto which they are installed to convey a sense of matching features, but also to ensure functionality and meet specific requirements. Discrete and essential, Noorth faucets fall into two collections (Flow and H2O), and are capable of meeting all kinds of installation requirements thanks to a wide range of models available. Designed for washbasins, bathtubs, and bathroom fittings in general, whether floor-mounted, free-standing or wall-mounted, Noorth faucets are available in polished, brushed and chrome stainless steel finishes.

Éléments fondamentaux pour compléter tout projet de salle de bain, les robinets dialoguent avec les éléments sur lesquels ils sont installés non seulement pour garantir une apparence uniforme mais aussi pour assurer un bon fonctionnement et répondre aux besoins spécifiques des clients. Présence discrète et essentielle, les robinets Noorth se déclinent en deux collections - Flow et H2O - dans un vaste éventail de modèles en mesure de répondre à toutes les exigences. Pensés pour les lavabos, les baignoires et les sanitaires et disponibles en versions pour plan, sol ou mur, les robinets Noorth existent en finition acier inox brillant, inox satiné ou chrome.

Was das Projekt der Raumgestaltung des Bades abrundet sind die Wasserhähne. Sie stehen in einem harmonischen Wechselspiel mit den Objekten, für die sie vorgesehen sind und gewährleisten gleichzeitig die Funktionalität der Einrichtungen, indem sie auch spezifischen Bedürfnissen gerecht werden. Ihr Erscheinungsbild kann diskret aber auch unübersehbar sein. Die Wasserhähne Noorth sind Bestandteile der breitgefächerten Kollektionen Flow und H2O und berücksichtigen dank der Vielzahl an verfügbaren Modellen jedweden Anspruch bezüglich Installation. Die sowohl für Waschbecken als auch für Badewannen und Sanitäranlagen konzipierten Noorth-Wasserhähne sind in den Ausführungen glänzender Edelstahl, satiniertes Edelstahl und Chromo erhältlich.

Необходимые для завершения проекта ванной комнаты, они взаимодействуют с элементами, на которых они установлены, создавая общую картину, и гарантируя при этом функциональность и соответствие определенным требованиям. Незаметные и необходимые краны Noorth предлагаются в двух коллекциях Flow и H2O. Благодаря широкому спектру моделей они способны удовлетворить любые требования к установке. Предназначенные для раковин, ванн и сантехники, для напольных, настенных или установленных на несущую поверхность вариантов, смесители Noorth могут иметь отделку в виде полированной или сатинированной нержавеющей стали и хромированной поверхности.



Flow L 20 | Flow L 25

a parete, lavabo | wall-mounted, washbasin | au mur, vasque | an der Wand, Waschbecken | настенная раковина

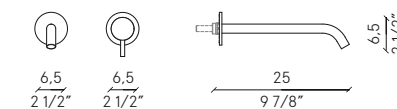
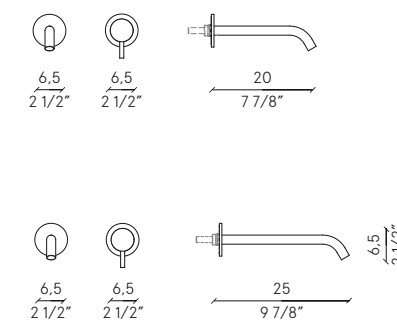

finiture | finishes | finitions | Oberflächen | отделки
metallo | metal | métal | Metall | металл



Flow H 35 | Flow H 40

da piano, lavabo | top-mounted, washbasin | sur plan, vasque | flächenbündig, Waschbecken | накладная раковина

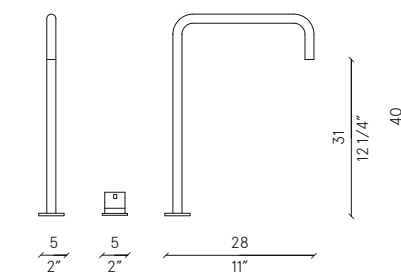
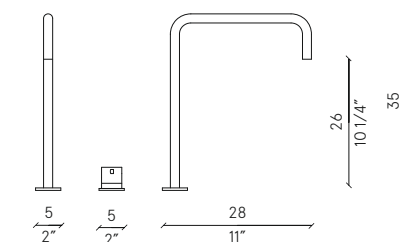

finiture | finishes | finitions | Oberflächen | отделки
metallo | metal | métal | Metall | металл

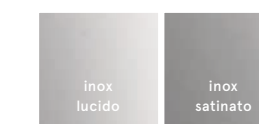

FLOW



TAPS



Flow H 16

da piano, lavabo | top-mounted, washbasin | sur plan, vasque | flächenbündig, Waschbecken | накладная, раковина

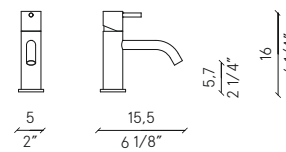

Flow H 22

da piano, lavabo | top-mounted, washbasin | sur plan, vasque | flächenbündig, Waschbecken | накладная, раковина

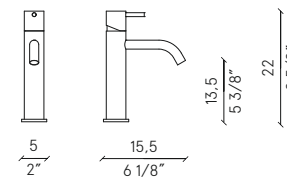

fniture | finishes | finitions | Oberflächen | отделки

metallo | metal | métal | Metall | металл



fniture | finishes | finitions | Oberflächen | отделки

metallo | metal | métal | Metall | металл



FLOW



TAPS



Flow H 35

da piano, lavabo | top-mounted, washbasin | sur plan, vasque | flächenbündig, Waschbecken | накладная, раковина

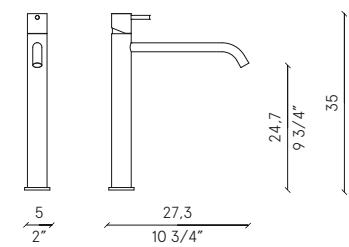

Flow H 45

da piano, lavabo | top-mounted, washbasin | sur plan, vasque | flächenbündig, Waschbecken | накладная, раковина

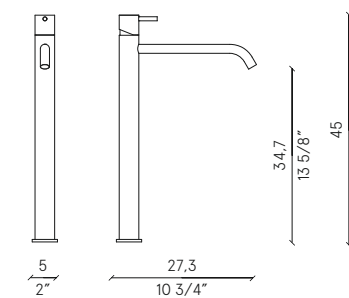

fniture | finishes | finitions | Oberflächen | отделки

metallo | metal | métal | Metall | металл

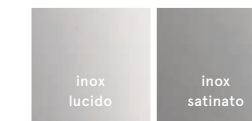

fniture | finishes | finitions | Oberflächen | отделки

metallo | metal | métal | Metall | металл



FLOW



Flow H 103

a pavimento, lavabo | floor-mounted, washbasin | au sol, vasque | am Fußboden, Waschbecken | напольная, раковина

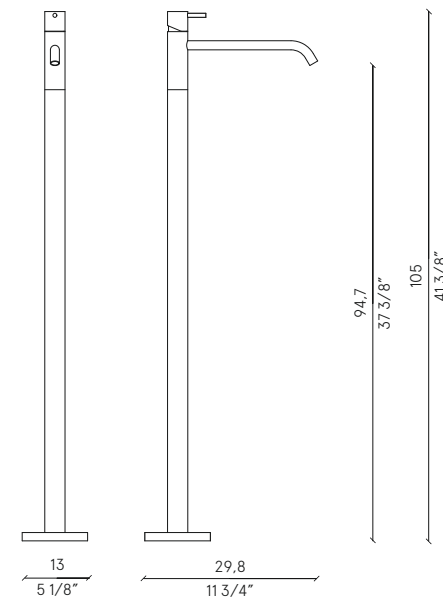

finiture | finishes | finitions | Oberflächen | отделки
metallo | metal | métal | Metall | металл



TAPS



Flow H 15 bidet

da piano, bidet | top mounted, bidet | sur plan, bidet | flächenbündig, Bidet | накладное, биде

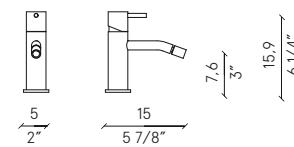

finiture | finishes | finitions | Oberflächen | отделки
metallo | metal | métal | Metall | металл

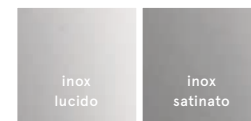

H2O



H2O

incasso, lavabo | inset, washbasin | encastrée, vasque | eingebaut, Waschbecken | встраиваемая, раковина

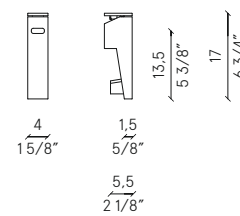

finiture | finishes | finitions | Oberflächen | отделки
metallo | metal | métal | Metall | металл

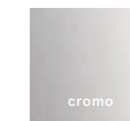

TAPS



H2O bidet

da piano, bidet | top mounted, bidet | sur plan, bidet | flächenbündig, Bidet | накладное, биде

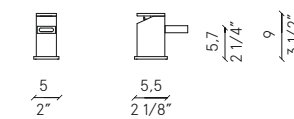

finiture | finishes | finitions | Oberflächen | отделки
metallo | metal | métal | Metall | металл

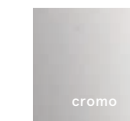

FLOW



TAPS



Flow D01

miscelatore a parete, doccia | wall-mounted mixer, shower | au mur mitigeur, douche | an der Wand Mischaggregat, Dusche | настенный смеситель, душ

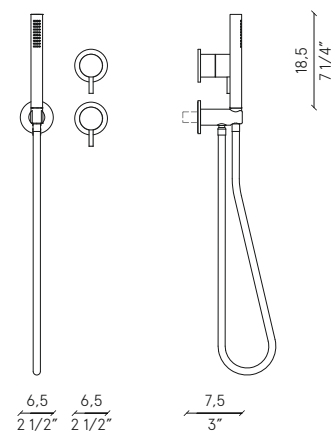

finiture | finishes | finitions | Oberflächen | отделки
metallo | metal | métal | Metall | металл



Flow D02

termostatico a parete, doccia | thermostatic wall-mounted, shower | au mur thermostatique, douche | an der Wand Thermostat, Dusche | настенный термостат, душ

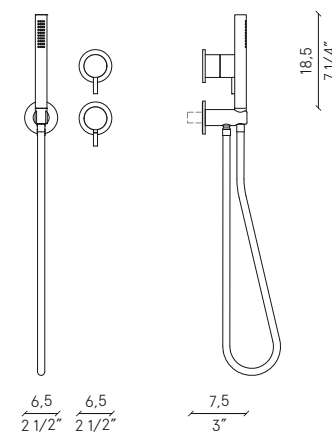

finiture | finishes | finitions | Oberflächen | отделки
metallo | metal | métal | Metall | металл



FLOW



TAPS



Flow S01

a soffitto, doccia | ceiling-mounted, shower | à plafond, douche | am Decke, Dusche | потолочная душевая лейка

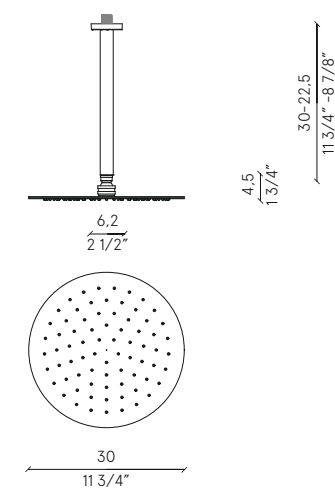

finiture | finishes | finitions | Oberflächen | отделки
metallo | metal | métal | Metall | металл

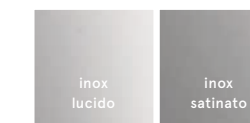

Flow S02

a parete, doccia | wall-mounted, shower | au mur, douche | an der Wand, Dusche | настенный, душ

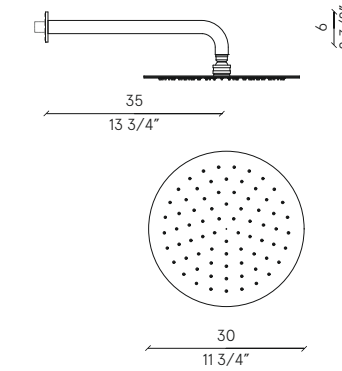

finiture | finishes | finitions | Oberflächen | отделки
metallo | metal | métal | Metall | металл

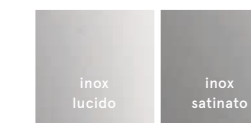

FLOW



Flow H 28

bordo vasca | bathtub edge | bord baignoire | Wannenrand | борт ванны

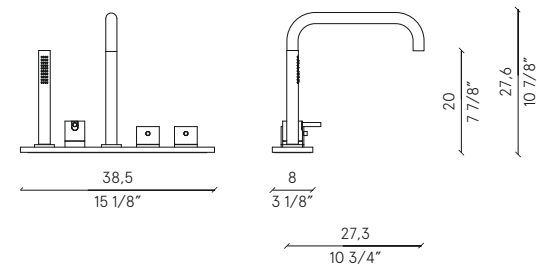

finiture | finishes | finitions | Oberflächen | отделки
metallo | metal | métal | Metall | металл



TAPS



Flow H 86

a pavimento, vasca | floor-mounted, bathtub | au sol, baignoire | am Fußboden, Wanne | напольная, ванна

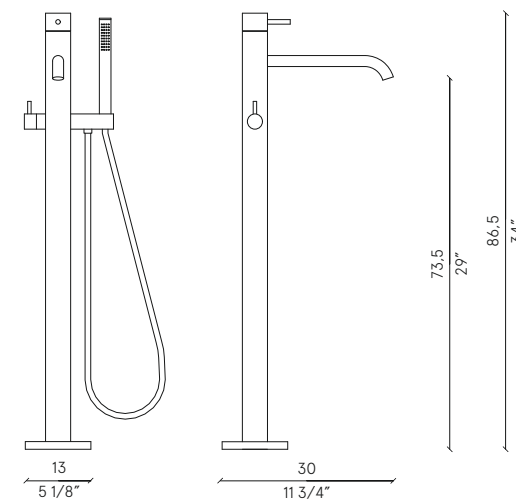

finiture | finishes | finitions | Oberflächen | отделки
metallo | metal | métal | Metall | металл



Presenza discreta, rapporto dimensionale equilibrato, ergonomia delle forme e facilità di collocazione all'interno del progetto bagno contemporaneo: i sanitari in ceramica della collezione Senna rappresentano una soluzione formale in grado di dialogare con naturalezza con elementi d'arredo diversi o per sviluppare trasversalmente linguaggi specifici. Sono proposti nella versione sospesa e nella finitura ceramica lucida o opaca.

With their discreet presence, balanced aspect ratio, ergonomic shapes and ease of placement within the contemporary bathroom project: sanitary ceramics from the Senna collection represent a stylistically formal solution capable of sitting comfortably alongside different pieces of furniture or of developing their own unique style-crossing combinations. They come in the wall-mounted version and in glossy or matt ceramic finishes.

Présence discrète, proportions équilibrées, ergonomie des formes et facilité de positionnement au sein des projets de salles de bain contemporains : les sanitaires en céramique de la collection Senna représentent une solution formelle en mesure de dialoguer naturellement avec les différents éléments d'ameublement ou d'élaborer universellement des langages spécifiques. Ils sont disponibles en version suspendue et en finition céramique mate ou brillante.

Diskret, ausgewogene Größenverhältnisse aufweisend, ergonomisch und formlich zum problemlosen Einbau ins Bad der Gegenwart konzipiert: Die Sanitäranlagen aus Keramik der Kollektion Senna sind so entworfen worden, dass sie sich natürlich ins Ambiente des Badezimmers einfügen und im harmonischen Wechselspiel mit den übrigen Einrichtungselementen stehen. Sie werden in hängender Ausführung aus glänzender oder matter Keramik angeboten.

Незаметное присутствие, сбалансированное пространственное соотношение, эргономичная форма и легкость размещения в рамках современного проекта ванной комнаты: керамическая сантехника коллекции Senna представляет собой формальное решение, способное естественно сочетаться с различными предметами мебели или создавать новые идеи. Предлагаются подвесные композиции и блестящая или матовая отделка керамики.



Senna bidet

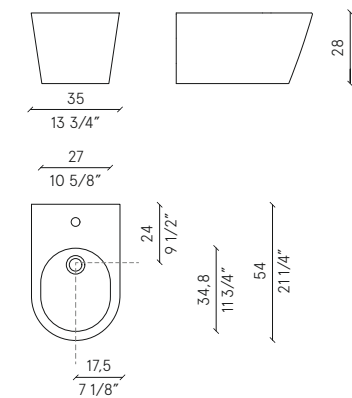

Senna WC

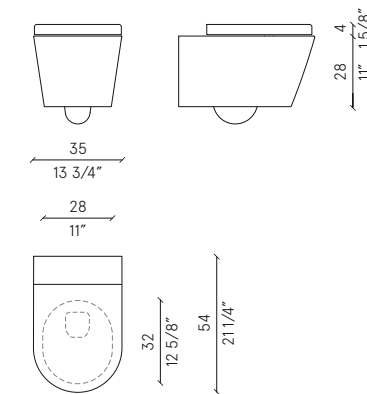

finiture | finishes | finitions | Oberflächen | отделки

ceramica
lucidaceramica
opaca

finiture | finishes | finitions | Oberflächen | отделки

ceramica
lucidaceramica
opaca

EQUIPMENT

TECHNICAL

La corretta gestione dello spazio interno di contenitori e cassetti è uno degli aspetti fondamentali di un progetto d'arredo bagno sartoriale e personalizzato, nel quale entra sempre più spesso a far parte anche ciò che è celato. Noorth propone una collezione trasversale di attrezzature interne che gioca sulla combinazione di materiali naturali: gli elementi divisorio sono realizzati in vetro per i cassetti alti e in legno per i cassetti bassi e le loro caratteristiche tecniche permettono configurazioni libere per le specifiche esigenze di contenimento.

Effectively managing the internal space of storage units and drawers is one of the fundamental aspects of a carefully tailored bathroom furnishing project, which must increasingly factor in all that is hidden from view. Noorth presents a style-crossing collection of internal equipment that plays on the combination of natural materials: divider elements are made of glass for deep drawers and of wood for shallow drawers and their technical features allow for imaginative configurations catering to specific storage needs.

La bonne gestion de l'espace intérieur des tiroirs et des éléments de rangement est l'un des aspects les plus importants des projets d'ameublement personnalisés et sur mesure des salles de bain, des projets où ce qui est caché revêt toujours plus d'importance. Noorth propose une collection universelle d'équipements intérieurs jouant sur le mariage de matériaux naturels : les dispositifs de séparation sont réalisés en verre pour les tiroirs hauts et en bois pour les tiroirs bas. Leurs caractéristiques techniques permettent des configurations libres répondant aux exigences de rangement de chacun.

Eine korrekte Raumanordnung im Innern der Behältnisse und Schubfächern ist die Voraussetzung für eine maßgeschneiderte und eine auf die persönlichen Bedürfnisse abgestimmte Badezimmereinrichtung, deren feste Bestandteile auch die für das Auge nicht sichtbaren Bereiche sind. Noorth präsentiert eine Kollektion von Innengestaltungen, die durch die Kombination von verschiedenen naturbelassenen Materialien besticht: So sind die Trennelemente der hohen Schubfächer aus Glas und die für die niedrigen aus Holz gefertigt. Ihre technischen Merkmale ermöglichen je nach Bedürfnis bezüglich Behältnis frei wählbare Ausführungen.

Правильное распределение внутреннего пространства мебели и ящиков является одним из основных аспектов индивидуального проекта оформления ванной комнаты, который все чаще включает в себя скрытые пространства. Noorth предлагает полную коллекцию внутренней мебели и оборудования, использующую необычные сочетания натуральных материалов: разделительные элементы высоких ящиков выполнены из стекла и перегородки низких ящиков из дерева, их технические характеристики позволяют создавать свободные конфигурации с учетом конкретных потребностей помещения.

EQUIPMENT

INNER



P I D I B I G 38,8 - 47,3 - 54,8 cm | 15 1/4" - 18 5/8" - 21 5/8"

base portallavabo | washbasin unit | meuble bas sous vasque | Waschbeckenunterschrank | тумба для раковины

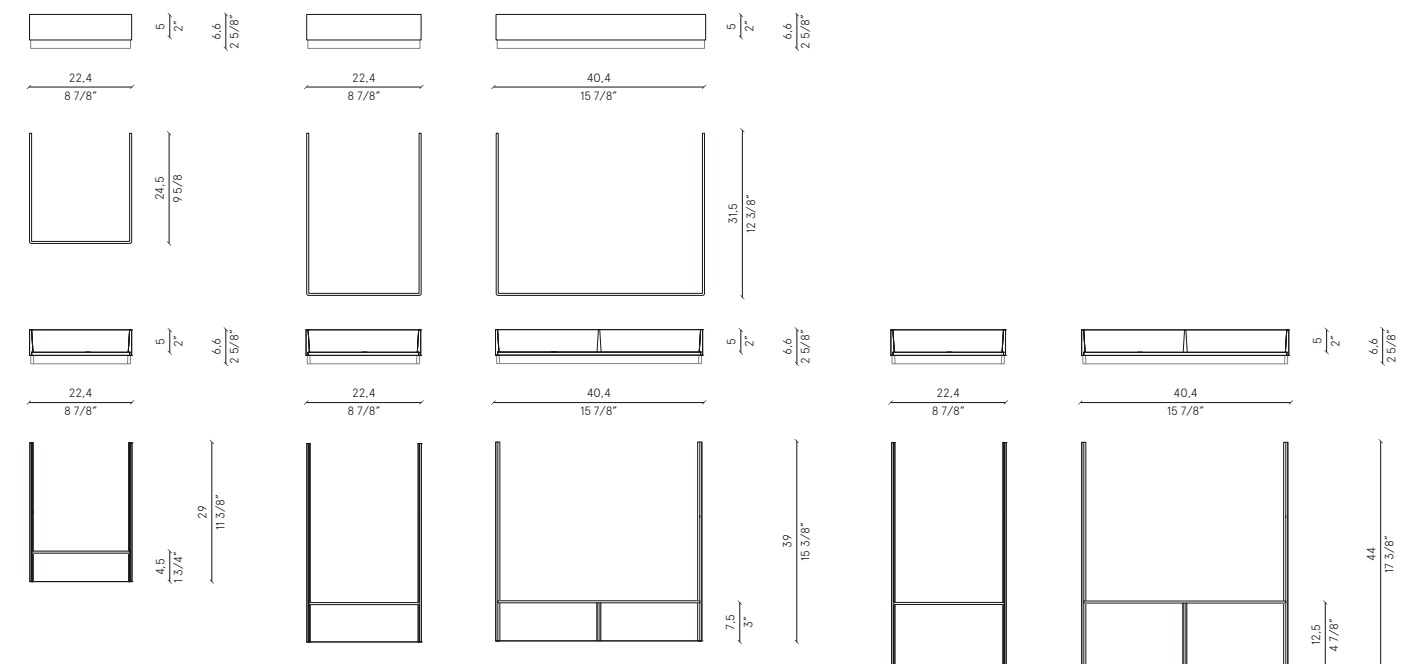

finiture | finishes | finitions | Oberflächen | отделки

metallo | metal | métal | Metall | металл

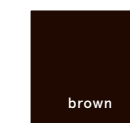

brown solo per basi finitura laminato | only for bases laminated finish | seulement pour les bases fini melaminé | nur für Basen Laminatendel | только для баз ламината отделки

finiture | finishes | finitions | Oberflächen | отделки

essenze opache | matt veneers | essences mates | matte Holze | матовые шпоны

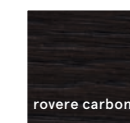

EQUIPMENT

INNER



PIDIBIG 38,8 - 47,3 - 54,8 cm | 15 1/4" - 18 5/8" - 21 5/8"

base componibile | base unit | meuble bas | Einbau-Unterschrank | тумба

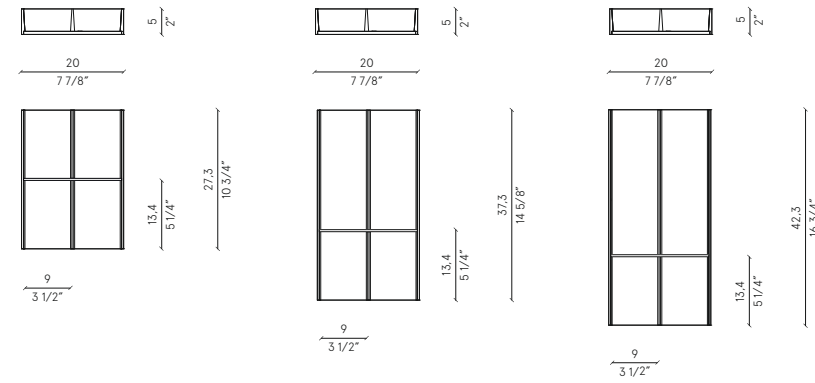

finiture | finishes | finitions | Oberflächen | отделки

essenze opache | matt veneers | essences mates | matte Holze | матовые шпоны

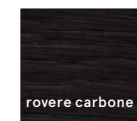

EQUIPMENT

INNER



PIDIBIG 38,8 - 47,3 - 54,8 cm | 15 1/4" - 18 5/8" - 21 5/8"

base componibile | base unit | meuble bas | Einbau-Unterschrank | тумба

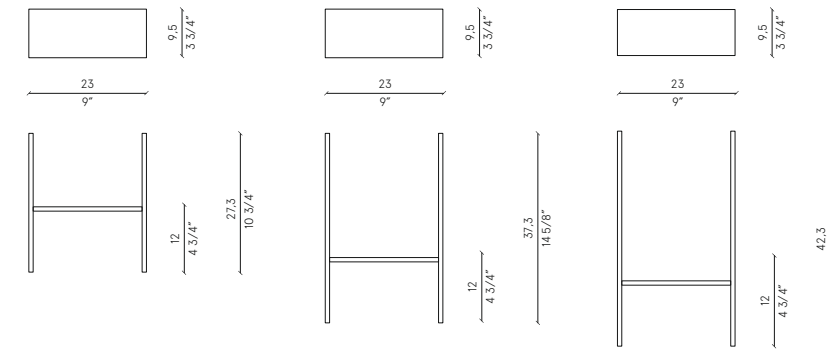

finiture | finishes | finitions | Oberflächen | отделки

vetri | glasses | verres | Gläser | стекла

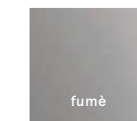

EQUIPMENT

INNER

attrezzatura interna in legno | wooden inner equipment | équipement intérieur en bois | Innere Einrichtung aus Holz | внутреннее оснащение из древесины
 base portallavabo | washbasin unit | meuble bas sous vasque | Waschbeckenunterschrank | тумба для раковины

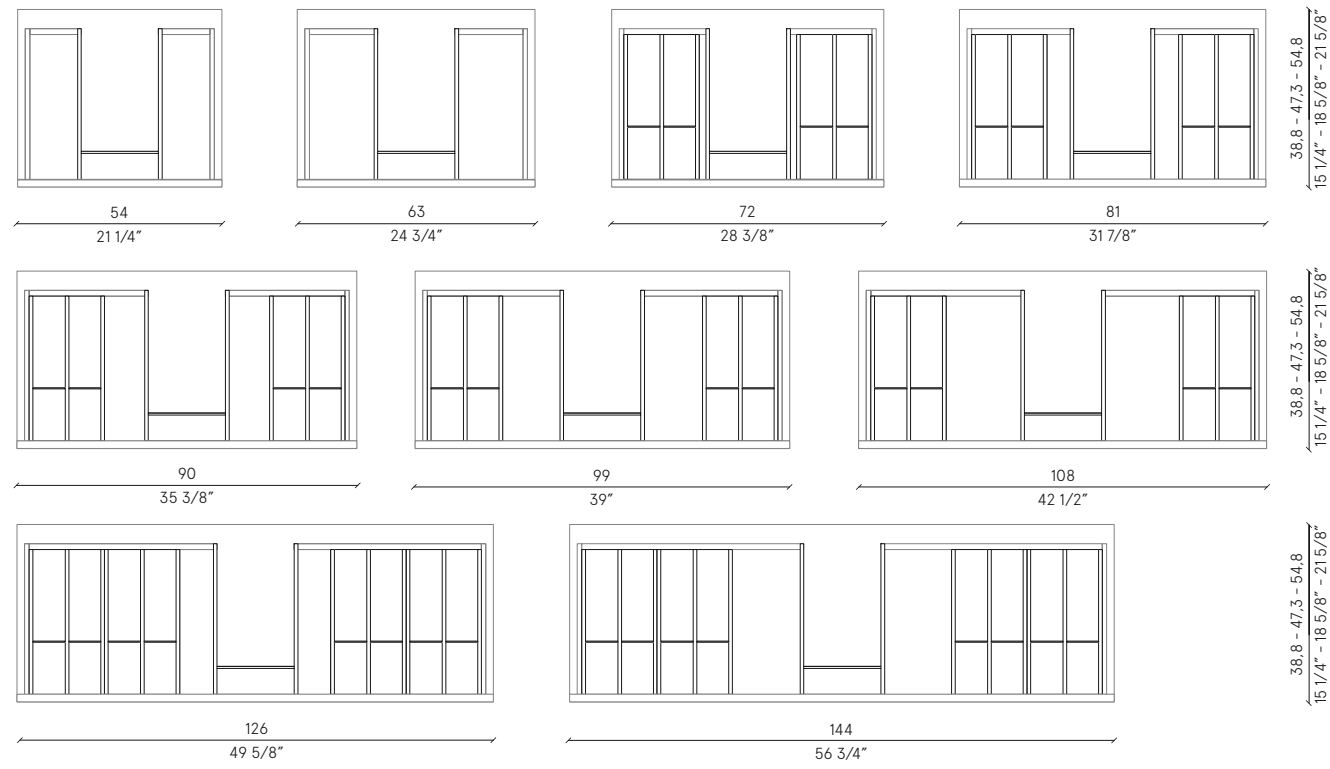

attrezzatura interna in legno | wooden inner equipment | équipement intérieur en bois | Innere Einrichtung aus Holz | внутреннее оснащение из древесины
 base portallavabo | washbasin unit | meuble bas sous vasque | Waschbeckenunterschrank | тумба для раковины

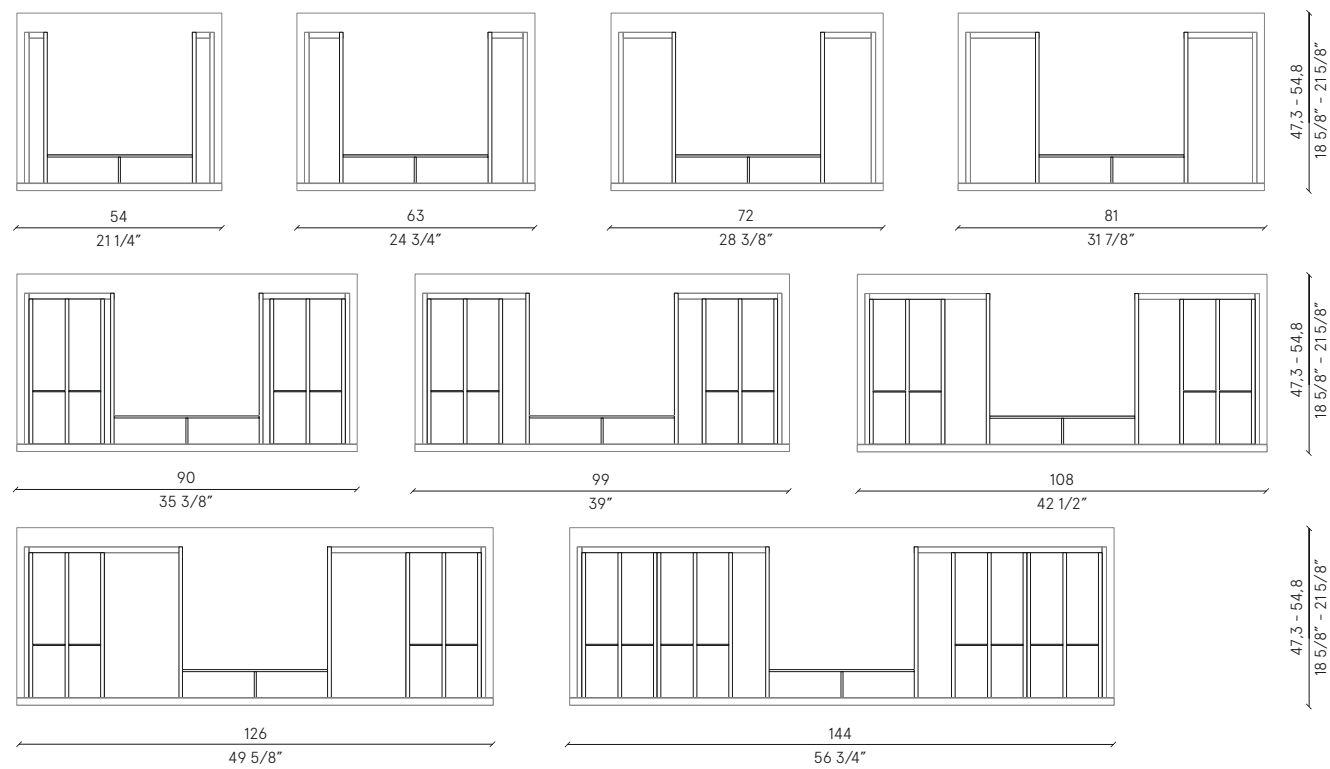

EQUIPMENT

INNER

attrezzatura interna in legno | wooden inner equipment | équipement intérieur en bois | Innere Einrichtung aus Holz | внутреннее оснащение из древесины
 base componibile | base unit | meuble bas | Einbau-Unterschrank | тумба

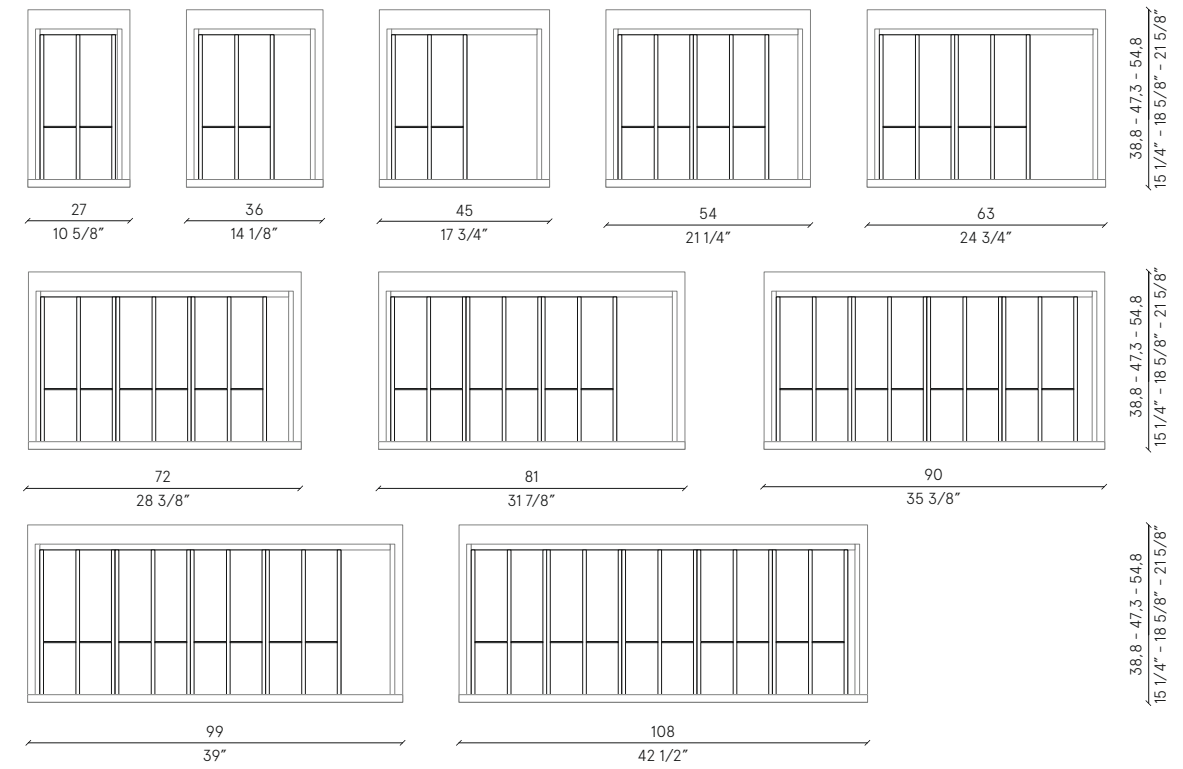

attrezzatura interna in vetro | glass inner equipment | équipement intérieur en verre | Innere Einrichtung aus Glas | внутреннее оснащение из стекла
 base componibile | base unit | meuble bas | Einbau-Unterschrank | тумба

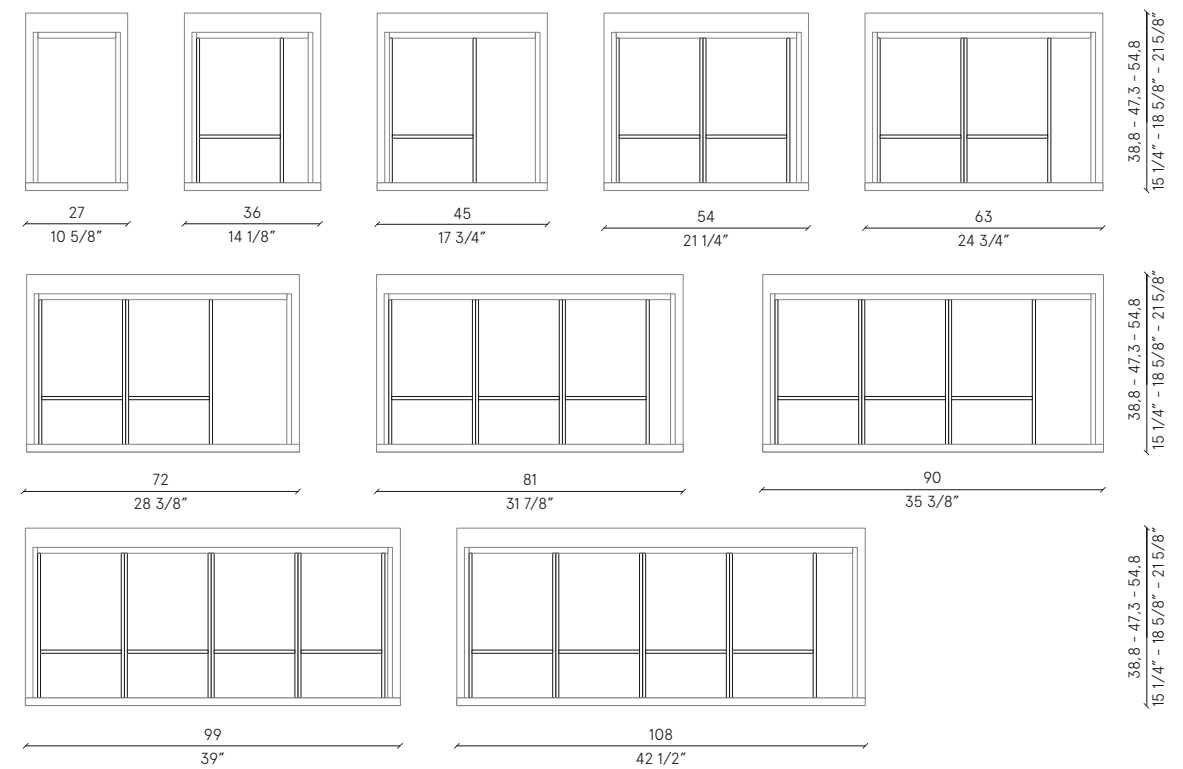

fourth chapter systems



PURO

TECHNICAL

Un design essenziale e raffinato fatto di superfici preziose e geometrie perfette, un sistema componibile che offre un'ampia varietà di soluzioni nel rispetto di un concept che nasce dall'essenza della materia, sempre preziosa, e dall'impostazione architettonica dello spazio con soluzioni strutturali pensate anche per configurazioni a isola. L'assenza della maniglia, sostituita da una gola che può trovare posto anche lateralmente, accentua la purezza dei volumi, così come i lavabi speciali che si integrano perfettamente nei top. La luce led integrata negli elementi ne sottolinea la geometria e valorizza i tratti inconfondibili di marmi, pietre e legni esclusivi.

With a minimalistic and elegant design enriched by precious surfaces and razor-sharp geometrical forms, this modular system offers a wide variety of solutions while staying true to a concept that draws inspiration from the ever-precious essence of matter and from the architectural signature in interiors with structural solutions also engineered for island-based layouts. The lack of the door handle, replaced by a hand grip that can even be fitted on the sides, heightens the pure forms of the volumes, just like the distinctive wash basins that are perfectly built into the surface top. Deeply ensclosed in the composition the LED light underscores the geometry of the elements while enhancing the unmistakable features of premium materials such as marble, stone and veneer.

Un design essentiel et raffiné fait de surfaces luxueuses et de géométries parfaites, un système modulable offrant une large éventail de solutions dans le respect d'un concept fruit de l'essence même de la matière, toujours noble, et de la configuration architecturale de l'espace avec des solutions structurelles également conçues pour les agencements en îlots. L'absence de poignées, remplacées par des gorges pouvant également être placées sur le côté, accentue la pureté des volumes tout comme les lavabos spéciaux qui s'intègrent parfaitement dans les plans. L'éclairage led intégré dans les éléments sublime la géométrie tout en valorisant les caractéristiques inimitables du marbre, des pierres et des bois nobles.

Das sich aufs Wesentliche beschränkende und raffinierte Design, das aus edlen Oberflächen und perfekten geometrischen Formen besteht und eine Vielzahl von Möglichkeiten innerhalb eines Konzepts bietet, ist aus der besonderen Wertschätzung des verwendeten Materials und aus der architektonisch durchdachten Einteilung des Raumes mit selbst Inselkonfigurationen berücksichtigenden Gestaltungsideen hervorgegangen. Das Fehlen des Griffs, der durch Engstellen, das heißt Aussparungen ersetzt wurde, die auch auf der Seite befindlich ausgeführt werden können, unterstreicht die Reinheit der Rauminhalts auf ähnliche Weise, wie die speziellen Waschbecken sich perfekt in die Platten integrieren. Das in die Elemente integrierten Led-Lichter heben die geometrischen Formen hervor und werten die unverwechselbaren Eigenschaften von Marmor, Stein und Edelhölzern zusätzlich auf.

Изысканный и утонченный дизайн, включающий в себя драгоценные поверхности и безупречные геометрические формы, составная модульная система, предлагающая огромные возможности сочетаний. Концепция опирается на сущность драгоценных материалов, и на архитектурное осмысление пространства, включающего структурные решения, которые можно конфигурировать в качестве отдельно стоящего "острова". Отсутствие ручек, замененных углублением, которое может располагаться также сбоку, подчеркивает чистоту форм. Специальные раковины безупречно интегрируются в столешницы. Встроенная светодиодная подсветка элементов подчеркивает геометрию и придает ценность необычным характеристикам мрамора, камней и драгоценных сортов древесины.

tipologia | type | typologie | Art | типология

gola | groove handle | gorge | Griffleiste | наз

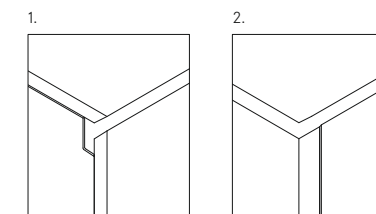

1. top a 45°, 2. top e fianchi di finitura a 45°
1. top with 45° chamfer, 2. top and finish sides with 45° chamfer
1. plan à 45°, 2. plan et côtés de finitions à 45°
1. Platte mit 45° Abkantung, 2. Platte und Ausführungsseiten mit 45° Abkantung
1. столешница на 45°, 2. столешница и боковые стенки на 45°

H | ВbC 23,9 cm | 9 3/8"

PIDIBIG	LIWIBISH
38,8	bc 27,36, 45, 54, 63, 72, 81, 90, 99, 108 ap 54, 63, 72, 81, 90, 99, 108
151/4"	bc 105/8", 141/8", 173/4", 211/4", 243/4", 283/8", 317/8", 353/8", 39", 42 1/2" ap 211/4", 243/4", 283/8", 317/8", 353/8", 39", 42 1/2"
47	bc 27,36, 45, 54, 63, 72, 81, 90, 99, 108 ap 54, 63, 72, 81, 90, 99, 108, 126, 144
181/2"	bc 105/8", 141/8", 173/4", 211/4", 243/4", 283/8", 317/8", 353/8", 39", 42 1/2" ap 211/4", 243/4", 283/8", 317/8", 353/8", 39", 42 1/2", 495/8", 563/4"
54,5	bc 27,36, 45, 54, 63, 72, 81, 90, 99, 108 ap 54, 63, 72, 81, 90, 99, 108, 126, 144
211/2"	bc 105/8", 141/8", 173/4", 211/4", 243/4", 283/8", 317/8", 353/8", 39", 42 1/2" ap 211/4", 243/4", 283/8", 317/8", 353/8", 39", 42 1/2", 495/8", 563/4"

cassetto
drawer
 tiroir
Schublade
ящик

H | ВbC 36,3 cm | 14 1/4"

PIDIBIG	LIWIBISH
38,8	ap 27,36, 45, 54, 63, 72, 81, 90, 99, 108
151/4"	ap 105/8", 141/8", 173/4", 211/4", 243/4", 283/8", 317/8", 353/8", 39", 42 1/2"
47	ap 27,36, 45, 54, 63, 72, 81, 90, 99, 108
181/2"	ap 105/8", 141/8", 173/4", 211/4", 243/4", 283/8", 317/8", 353/8", 39", 42 1/2"
54,5	ap 27,36, 45, 54, 63, 72, 81, 90, 99, 108
211/2"	ap 105/8", 141/8", 173/4", 211/4", 243/4", 283/8", 317/8", 353/8", 39", 42 1/2"

cassetto, vano a giorno
drawer, open element
 tiroir, élément à jour
Schublade, offenes Fach
ящик, открытый элемент

H | ВbC 36,3 cm | 14 1/4"

PIDIBIG	LIWIBISH
38,8	bc 27,36, 45, 54, 63, 72, 81, 90, 99, 108 ap 54, 63, 72, 81, 90, 99, 108
151/4"	bc 105/8", 141/8", 173/4", 211/4", 243/4", 283/8", 317/8", 353/8", 39", 42 1/2" ap 211/4", 243/4", 283/8", 317/8", 353/8", 39", 42 1/2"
47	bc 27,36, 45, 54, 63, 72, 81, 90, 99, 108 ap 54, 63, 72, 81, 90, 99, 108, 126, 144
181/2"	bc 105/8", 141/8", 173/4", 211/4", 243/4", 283/8", 317/8", 353/8", 39", 42 1/2" ap 211/4", 243/4", 283/8", 317/8", 353/8", 39", 42 1/2", 495/8", 563/4"
54,5	bc 27,36, 45, 54, 63, 72, 81, 90, 99, 108 ap 54, 63, 72, 81, 90, 99, 108, 126, 144
211/2"	bc 105/8", 141/8", 173/4", 211/4", 243/4", 283/8", 317/8", 353/8", 39", 42 1/2" ap 211/4", 243/4", 283/8", 317/8", 353/8", 39", 42 1/2", 495/8", 563/4"

cassetto, optional cassetto interno
drawer, optional inner drawer
 grand tiroir, optionnel tiroir interne
 Schubkasten, optional innere Schublade
 большой ящик, факультативно внутренний ящик

H | ВbC 36,3 cm | 14 1/4"

PIDIBIG	LIWIBISH
38,8	bc 27,36, 45, 54, 63, 72, 81, 90, 99, 108 ap 54, 63, 72, 81, 90, 99, 108
151/4"	bc 105/8", 141/8", 173/4", 211/4", 243/4", 283/8", 317/8", 353/8", 39", 42 1/2" ap 211/4", 243/4", 283/8", 317/8", 353/8", 39", 42 1/2"
47	bc 27,36, 45, 54, 63, 72, 81, 90, 99, 108 ap 54, 63, 72, 81, 90, 99, 108, 126, 144
181/2"	bc 105/8", 141/8", 173/4", 211/4", 243/4", 283/8", 317/8", 353/8", 39", 42 1/2" ap 211/4", 243/4", 283/8", 317/8", 353/8", 39", 42 1/2", 495/8", 563/4"
54,5	bc 27,36, 45, 54, 63, 72, 81, 90, 99, 108 ap 54, 63, 72, 81, 90, 99, 108, 126, 144
211/2"	bc 105/8", 141/8", 173/4", 211/4", 243/4", 283/8", 317/8", 353/8", 39", 42 1/2" ap 211/4", 243/4", 283/8", 317/8", 353/8", 39", 42 1/2", 495/8", 563/4"

cassetti
drawers
 tiroirs
 Schubladen
 ящики

H ВxС 46,1 cm 18 1/8"	PIDIBIG	LIWIBIШ
	38,8	вс 27*, 36*, 45*, 54, 63, 72, 81, 90, 99, 108 вр 54*, 63, 72, 81, 90, 99, 108
	151/4"	вс 105/8", 141/8", 173/4", 211/4", 243/4", 283/8", 317/8", 353/8", 39", 421/2" вр 211/4", 243/4", 283/8", 317/8", 353/8", 39", 421/2"
	47	вс 27*, 36*, 45*, 54, 63, 72, 81, 90, 99, 108 вр 54*, 63, 72, 81, 90, 99, 108, 126, 144
	181/2"	вс 105/8", 141/8", 173/4", 211/4", 243/4", 283/8", 317/8", 353/8", 39", 421/2" вр 211/4", 243/4", 283/8", 317/8", 353/8", 39", 421/2", 495/8", 563/4"
	54,5	вс 27*, 36*, 45*, 54, 63, 72, 81, 90, 99, 108 вр 54*, 63, 72, 81, 90, 99, 108, 126, 144
	211/2"	вс 105/8", 141/8", 173/4", 211/4", 243/4", 283/8", 317/8", 353/8", 39", 421/2" вр 211/4", 243/4", 283/8", 317/8", 353/8", 39", 421/2", 495/8", 563/4"

anta o cassettone, optional cassetto interno
door or drawer, optional inner drawer
porte o grand tiroir, optionnel tiroir interne
Tür und Schubkasten, optional innere Schublade
дверка или большой ящик, факультативно внутренний ящик

H ВxС 46,1 cm 18 1/8"	PIDIBIG	LIWIBIШ
	38,8	вс 27*, 36*, 45*, 54, 63, 72, 81, 90, 99, 108 вр 54*, 63, 72, 81, 90, 99, 108
	151/4"	вс 105/8", 141/8", 173/4", 211/4", 243/4", 283/8", 317/8", 353/8", 39", 421/2" вр 211/4", 243/4", 283/8", 317/8", 353/8", 39", 421/2"
	47	вс 27*, 36*, 45*, 54, 63, 72, 81, 90, 99, 108 вр 54*, 63, 72, 81, 90, 99, 108, 126, 144
	181/2"	вс 105/8", 141/8", 173/4", 211/4", 243/4", 283/8", 317/8", 353/8", 39", 421/2" вр 211/4", 243/4", 283/8", 317/8", 353/8", 39", 421/2", 495/8", 563/4"
	54,5	вс 27*, 36*, 45*, 54, 63, 72, 81, 90, 99, 108 вр 54*, 63, 72, 81, 90, 99, 108, 126, 144
	211/2"	вс 105/8", 141/8", 173/4", 211/4", 243/4", 283/8", 317/8", 353/8", 39", 421/2" вр 211/4", 243/4", 283/8", 317/8", 353/8", 39", 421/2", 495/8", 563/4"

cassetto, anta o cassettone
drawer, door or drawer
tiroir, porte o grand tiroir
Schublade, Tür oder Schubkasten
ящик, дверка или большой ящик

H ВxС 46,1 cm 18 1/8"	PIDIBIG	LIWIBIШ
	38,8	вс 54, 72, 90 вр 72, 90, 108
	151/4"	вс 211/4", 283/8", 353/8" вр 283/8", 353/8", 421/2"
	47	вс 54, 72, 90 вр 72, 90, 108
	181/2"	вс 211/4", 283/8", 353/8" вр 283/8", 353/8", 421/2"
	54,5	вс 54, 72, 90 вр 72, 90, 108
	211/2"	вс 211/4", 283/8", 353/8" вр 283/8", 353/8", 421/2"

ante, optional cassetto interno
doors, optional inner drawer
portes, optionnel tiroir interne
Türen, optional innere Schublade
дверки, факультативно внутренний ящик

H ВxС 46,1 cm 18 1/8"	PIDIBIG	LIWIBIШ
	38,8	вс 27, 36, 45, 54, 63, 72, 81, 90, 99, 108 вс 105/8", 141/8", 173/4", 211/4", 243/4", 283/8", 317/8", 353/8", 39", 421/2"
	151/4"	вс 105/8", 141/8", 173/4", 211/4", 243/4", 283/8", 317/8", 353/8", 39", 421/2" вс 105/8", 141/8", 173/4", 211/4", 243/4", 283/8", 317/8", 353/8", 39", 421/2"
	47	вс 27, 36, 45, 54, 63, 72, 81, 90, 99, 108 вс 105/8", 141/8", 173/4", 211/4", 243/4", 283/8", 317/8", 353/8", 39", 421/2"
	181/2"	вс 105/8", 141/8", 173/4", 211/4", 243/4", 283/8", 317/8", 353/8", 39", 421/2" вс 105/8", 141/8", 173/4", 211/4", 243/4", 283/8", 317/8", 353/8", 39", 421/2"
	54,5	вс 27, 36, 45, 54, 63, 72, 81, 90, 99, 108 вс 105/8", 141/8", 173/4", 211/4", 243/4", 283/8", 317/8", 353/8", 39", 421/2"
	211/2"	вс 105/8", 141/8", 173/4", 211/4", 243/4", 283/8", 317/8", 353/8", 39", 421/2" вс 105/8", 141/8", 173/4", 211/4", 243/4", 283/8", 317/8", 353/8", 39", 421/2"

cassetto, vano a giorno
drawer, open element
tiroir, élément à jour
Schublade, offenes Fach
ящик, открытый элемент

H ВxС 69,1 cm 27 1/4"	PIDIBIG	LIWIBIШ
	38,8	вс 27*, 36*, 45*, 54, 63, 72 вр 54*, 63, 72
	151/4"	вс 105/8", 141/8", 173/4", 211/4", 243/4", 283/8" вр 211/4", 243/4", 283/8"
	47	вс 27*, 36*, 45*, 54, 63, 72, 81, 90, 99, 108 вр 54*, 63, 72, 81, 90, 99, 108
	181/2"	вс 105/8", 141/8", 173/4", 211/4", 243/4", 283/8", 317/8", 353/8", 39", 421/2" вр 211/4", 243/4", 283/8", 317/8", 353/8", 39", 421/2"
	54,5	вс 27*, 36*, 45*, 54, 63, 72, 81, 90, 99, 108 вр 54*, 63, 72, 81, 90, 99, 108
	211/2"	вс 105/8", 141/8", 173/4", 211/4", 243/4", 283/8", 317/8", 353/8", 39", 421/2" вр 211/4", 243/4", 283/8", 317/8", 353/8", 39", 421/2"

anta o cassettone, optional cassetto interno
door or drawer, optional inner drawer
porte o grand tiroir, optionnel tiroir interne
Tür und Schubkasten, optional innere Schublade
дверка или большой ящик, факультативно внутренний ящик

H ВxС 69,1 cm 27 1/4"	PIDIBIG	LIWIBIШ
	38,8	вс 27*, 36*, 45*, 54, 63, 72 вр 54, 63, 72
	151/4"	вс 105/8", 141/8", 173/4", 211/4", 243/4", 283/8" вр 211/4", 243/4", 283/8"
	47	вс 27*, 36*, 45*, 54, 63, 72, 81, 90, 99, 108 вр 54, 63, 72, 81, 90, 99, 108
	181/2"	вс 105/8", 141/8", 173/4", 211/4", 243/4", 283/8", 317/8", 353/8", 39", 421/2" вр 211/4", 243/4", 283/8", 317/8", 353/8", 39", 421/2"
	54,5	вс 27*, 36*, 45*, 54, 63, 72, 81, 90, 99, 108 вр 54, 63, 72, 81, 90, 99, 108
	211/2"	вс 105/8", 141/8", 173/4", 211/4", 243/4", 283/8", 317/8", 353/8", 39", 421/2" вр 211/4", 243/4", 283/8", 317/8", 353/8", 39", 421/2"

cassetto, anta o cassettone, optional cassetto interno
drawer, door or drawer, optional inner drawer
tiroir, porte o grand tiroir, optionnel tiroir interne
Schublade, Tür oder Schubkasten, optional innere Schublade
ящик, дверка или большой ящик, внутренний ящик

H ВxС 69,1 cm 27 1/4"	PIDIBIG	LIWIBIШ
	38,8	вс 27, 36, 45, 54, 63, 72 вр 54, 63, 72
	151/4"	вс 105/8", 141/8", 173/4", 211/4", 243/4", 283/8" вр 211/4", 243/4", 283/8"
	47	вс 27, 36, 45, 54, 63, 72, 81, 90, 99, 108 вр 54, 63, 72, 81, 90, 99, 108
	181/2"	вс 105/8", 141/8", 173/4", 211/4", 243/4", 283/8", 317/8", 353/8", 39", 421/2" вр 211/4", 243/4", 283/8", 317/8", 353/8", 39", 421/2"
	54,5	вс 27, 36, 45, 54, 63, 72, 81, 90, 99, 108 вр 54, 63, 72, 81, 90, 99, 108
	211/2"	вс 105/8", 141/8", 173/4", 211/4", 243/4", 283/8", 317/8", 353/8", 39", 421/2" вр 211/4", 243/4", 283/8", 317/8", 353/8", 39", 421/2"

cassetti, cassettone
drawers, drawer
tiroirs, grand tiroir
Schubladen, Schubkasten
ящички, большой ящик

H ВxС 69,1 cm 27 1/4"	PIDIBIG	LIWIBIШ
	38,8	вс 54, 72, 90 вр 72, 90
	151/4"	вс 211/4", 283/8", 353/8" вр 283/8", 353/8"
	47	вс 54, 72, 90 вр 72, 90, 108
	181/2"	вс 211/4", 283/8", 353/8" вр 283/8", 353/8", 421/2"
	54,5	вс 54, 72, 90 вр 72, 90, 108
	211/2"	вс 211/4", 283/8", 353/8" вр 283/8", 353/8", 421/2"

ante, optional cassetto interno
doors, optional inner drawer
portes, optionnel tiroir interne
Türen, optional innere Schublade
дверки, факультативно внутренний ящик

H ВxС 23,9 - 36,3 - 46,1 - 69,1 cm 9 3/8" - 14 1/4" - 18 1/8" - 27 1/4"	PIDIBIG	LIWIBIШ
	38,8	4,5
	151/4"	13/4"
	47	4,5
	181/2"	13/4"
	54,5	4,5
	211/2"	13/4"

fianco di finitura
finish side
côté de finition
Ausführungsseite
боковая стенка

P D B Г 38,8 - 47,3 - 54,8 cm 15 1/4" - 18 5/8" - 21 5/8"	LIWIBIШ
	da 54 a 288 from 21 1/4" to 113 3/8" de 54 à 288 ab 54 zu 288 от 54 до 288

top per basi sp. 1,9 cm
tops for base units th. 3/4"
plans pour meubles bas ép. 1,9 cm
Schrankplatte Di. 1,9 cm
столешница тол. 1,9 cm

H ВxС 5 - 14,5 cm 2" - 5 3/4"	PIDIBIG	LIWIBIШ
	38,8	da 27 a 288 from 10 5/8" to 113 3/8"
	151/4"	de 27 à 288 ab 27 zu 288 от 27 до 288
	47	
	181/2"	
	54,5	
	211/2"	

zoccolo per basi
plinth for units
socle pour meubles
Sockel für Möbel
цоколь для тумб

parete di sostegno supporting walls supports muraux Stützwand опорные стены	H ВxС	PIDIBIG	LIWIBIШ
	A. 230 - 270 90 1/2" - 106 1/4"	30 113/4"	72, 90, 108, 126 283/8", 353/8", 421/2", 495/8"
	B. 125 49 1/4"	35 133/4"	108, 126, 144, 162, 180 421/2", 495/8", 563/4", 633/4", 707/8"

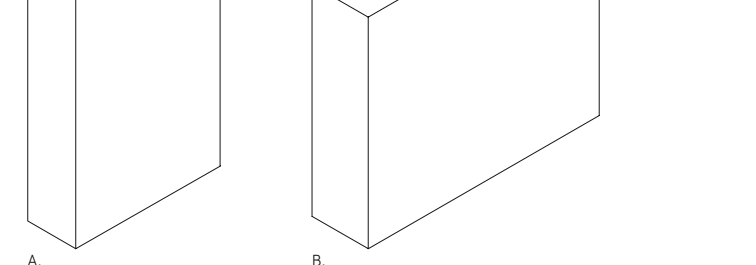

per composizione a sbalzo, optional predisposizione per sanitari
for cantilever composition, optional provision for sanitaryware
pour composition en porte-à-faux, attente pour sanitaires en option
für freihängende Anlage, optionale Vorbereitung für Sanitäranlagen
для выступающая композиция, факультативно оборудования кустановке сантехники

вс base componibile | base unit | meuble bas | Einbau-Unterschrank | тумба
вр base portalavabo | washbasin unit | meuble bas sous vasque | Waschbeckenunterschrank | тумба для раковины
* variante con anta | door version | variante avec porte | Variante mit Tür | вариант с дверкой

frontali, fianchi | fronts, sides | façades, côtés | Fronten, Seiten | фасады, боковые стенки

laccati opachi e lucidi | matt and glossy lacquers | laques mates et brillantes | Matt- und Glanzlacken | матовые-глянцевые лакировки



essenze opache | matt veneers | essences mates | matte Holze | матовые шпоны



essenza lucida | glossy veneer | essence brillante | glanzes Furnier | глянцевый шпон

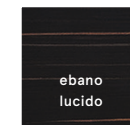

argille | clays | argiles | Lehm | глины



marmi opachi | matt marbles | marbres mates | Marmor Matt | матовые мраморы

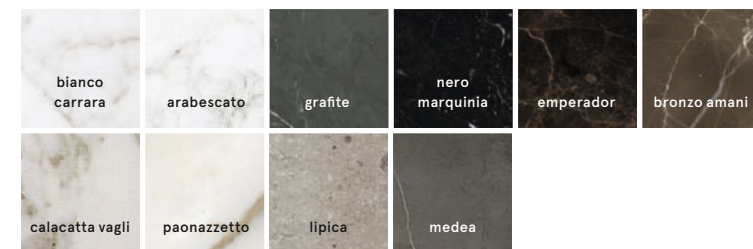

gola | groove | gorge | Griffleiste | нас

laccati opachi e lucidi | matt and glossy lacquers | laques mates et brillantes | Matt- und Glanzlacken | матовые-глянцевые лакировки



laccati anodizzati | painted anodised | laqués anodisés | Lackiert eloxiert | лакировка анодирование

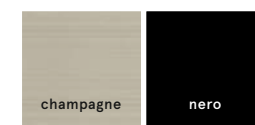

top | tops | plans | Platten | столешницы

laccati opachi e lucidi, vetri | matt and glossy lacquers, glass | laques mates et brillantes, verre | Matt- und Glanzlacken, Gläser | матовые-глянцевые лакировки, стекла



essenze opache | matt veneers | essences mates | matte Holze | матовые шпоны



essenza lucida | glossy veneer | essence brillante | glanzes Furnier | глянцевый шпон

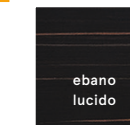

argille | clays | argiles | Lehm | глины

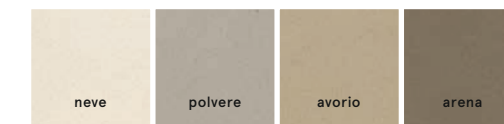

sintetici | compounds | synthétiques | Kunststoff | соединений



marmi opachi | matt marbles | marbres mates | Marmor Matt | матовые мраморы

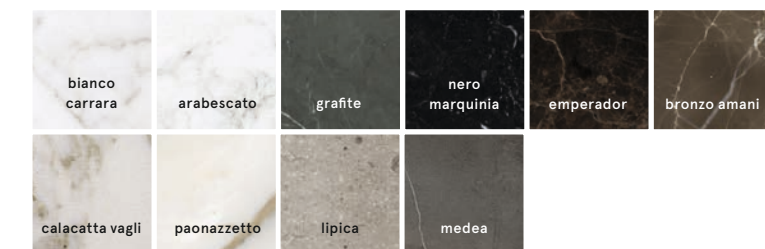

SINTESI

Una proposta versatile e trasversale che consente un'ampia libertà compositiva, grazie a elementi e accessori diversi, tutti contraddistinti da un rigore assoluto e dalla possibilità di scegliere tra tre tipologie di apertura: maniglia, gola o push-pull. Dalle specchiere retroilluminare con mensole portaoggetti, ai lavabi integrati o da appoggio di diverse forme con bordi sottili, dai top ottenuti da materiali preziosi ai contenitori con layout diversi che contemplano la presenza anche di vani a giorno, tutti realizzati con materiali unici ed ecosostenibili.

A versatile and cross-purpose proposal allowing utmost freedom of composition, thanks to a wide range of elements and accessories, whose common denominator is uncompromising stylistic rigor, and that all feature the possibility of choosing among three types of door opening systems: handle, hand grip or push-pull. From the backlit mirrors with shelves, to integrated or stand-alone washbasin units in different shapes and with thin edges, from the surface tops in precious materials to containers with different layouts and a mix of closed or open-fronted units, all these are made with high quality, environmentally friendly materials.

Une proposition polyvalente et transversale permettant une grande liberté de composition grâce à des éléments et accessoires différents se distinguant tous par une rigueur absolue et par la possibilité de choisir entre trois types d'ouverture : poignée, gorge ou push-pull. Des miroirs rétro-éclairés avec tablettes porte-objets aux lavabos - intégrés ou posés - à bords fins de différentes formes en passant par les plans réalisés en matières nobles et par les éléments de rangement modulables en plusieurs configurations et parfois dotés de niches ouvertes, tous les produits sont fabriqués avec des matériaux uniques et respectueux de l'environnement.

Eine vielseitige Lösung, die bei der Gestaltung dank unterschiedlich beschaffener Elemente und Zubehörteile, die sich alle durch ihren hohen Grad an Formstrenge auszeichnen, den größtmöglichen Spielraum lässt, auch in Bezug auf die Auswahl der Türöffnungssysteme: Türgriff, Aussparungen oder Touch-System. Von den hintergrundbeleuchteten Wandspiegeln mit Auflageflächen bis zu den eingebauten Waschbecken oder von den Auflagen unterschiedlichster Formen mit feinem Abschluss bis zu den aus wertvollen Materialien gefertigten Behältnissen, deren Erscheinungsbild auch dem Vorhandensein von türlosen Regalen Rechnung trägt, sind alle Objekte aus einzigartigen und nachhaltigen Werkstoffen gefertigt.

Гибкое решение, обеспечивающее большую свободу при создании интерьера, благодаря наличию различных элементов и аксессуаров, объединенных совершенством и строгостью форм, с несколькими вариантами открытия: за ручку, углубление или прикосновение. Подсвеченные зеркала с полочками для размещения предметов, встроенные или опирающиеся на столешницу раковины различной формы с тонкими краями, столешницы из драгоценных материалов, шкафчики с различным внутренним расположением, включающие открытые отсеки. Вся мебель выполнена из уникальных и экологически чистых материалов.

TECHNICAL

tipologia | type | typologie | Art | типология

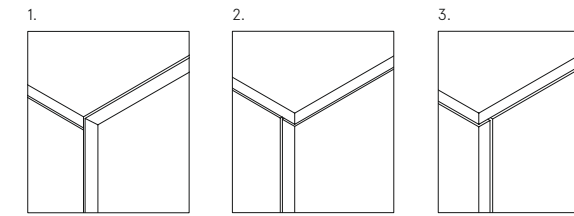

1. cielo finito (escluso gola), 2. top, 3. top e fianchi di finitura
1. finished carcass top (without groove handle), 2. top, 3. top and finish sides
1. couvercle en finition (sans gorge latérale), 2. plan, 3. plan et côtés de finition
1. Ausgeführtes Oberteil (außer Griffleiste), 2. Platte, 3. Platte und Ausführungsseiten
1. отделанная верхняя часть, 2. столешница, 3. столешница и боковые стенки

maniglie | handles | poignées | Handgriffe | ручки

M051

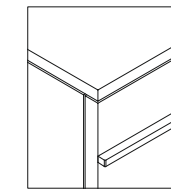

finitura Brill e laccati
bril and laquers finish
finition bril et laques
Ausführung Brill und lackiert
отделке брил и лакированных цветов

gola | groove handle | gorge | Griffleiste | нас

M90 - superiore | upper | supérieure | oben | верхний

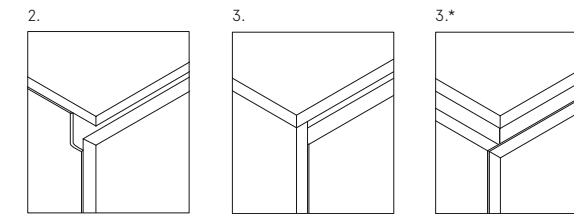

laccata, laccata anodizzata
lacquered colour, lacquered anodized
laquée, laques anodisés
Lackiert, Lackiert anodisiert
цветов, лакировки анодированы

* gola anche laterale
* side groove handle
* gorge latérale
* Griffleiste
* боковым пазом

push pull | push latch | loqueteau push-pull | Touch-System | нажимная защелка

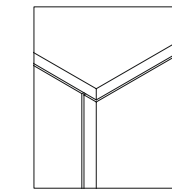

per aprire premere nella parte centrale
push latch in the middle of the front
ouverture par pression au milieu
zum Öffnen in der Mitte drücken
нажимная защелка в середине фасада

gola | groove handle | gorge | Griffleiste | нас

M91 - centrale | central | centrale | mittlere | центральный

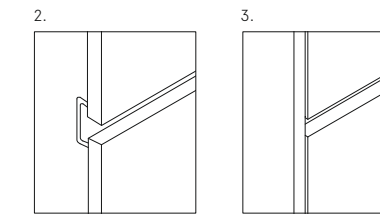

laccata, laccata anodizzata
lacquered colour, lacquered anodized
laquée, laques anodisés
Lackiert, Lackiert anodisiert
цветов, лакировки анодированы

H | ВbC 23,9 cm | 9 3/8"

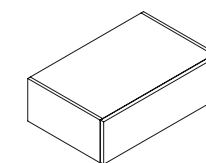

cassetto
drawer
 tiroir
Schublade
ящик

PIDIBIG LIWIBISH

38,8	вс	27,36, 45, 54, 63, 72, 81, 90, 99, 108
	вп	54, 63, 72, 81, 90, 99, 108
151/4"	вс	105/8", 141/8", 173/4", 211/4", 243/4", 283/8", 317/8", 353/8", 39", 42 1/2"
	вп	211/4", 243/4", 283/8", 317/8", 353/8", 39", 42 1/2"
47	вс	27,36, 45, 54, 63, 72, 81, 90, 99, 108
	вп	54, 63, 72, 81, 90, 99, 108, 126, 144
18 1/2"	вс	105/8", 141/8", 173/4", 211/4", 243/4", 283/8", 317/8", 353/8", 39", 42 1/2"
	вп	211/4", 243/4", 283/8", 317/8", 353/8", 39", 42 1/2", 495/8", 563/4"
54,5	вс	27,36, 45, 54, 63, 72, 81, 90, 99, 108
	вп	54, 63, 72, 81, 90, 99, 108, 126, 144
211/2"	вс	105/8", 141/8", 173/4", 211/4", 243/4", 283/8", 317/8", 353/8", 39", 42 1/2"
	вп	211/4", 243/4", 283/8", 317/8", 353/8", 39", 42 1/2", 495/8", 563/4"

H | ВbC 23,9 - 36,3 cm | 9 3/8" - 14 1/4"

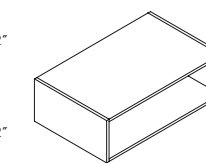

vano a giorno
open vanity
élément à jour
offenes Fach
открытый элемент

PIDIBIG LIWIBISH

38,8	вс	27,36, 45
151/4"	вс	105/8", 141/8", 173/4"
47	вс	27,36, 45
18 1/2"	вс	105/8", 141/8", 173/4"
54,5	вс	27,36, 45
211/2"	вс	105/8", 141/8", 173/4"

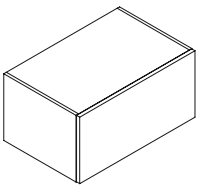
H BbIC 36,3 cm 14 1/4"	PIDIBIG	LIWIBIШ
	38,8	вс 27,36,45,54,63,72,81,90,99,108 вр 54,63,72,81,90,99,108
	151/4"	вс 105/8",141/8",173/4",211/4",243/4",283/8",317/8",353/8",39",421/2" вр 211/4",243/4",283/8",317/8",353/8",39",421/2"
	47	вс 27,36,45,54,63,72,81,90,99,108 вр 54,63,72,81,90,99,108,126,144
	181/2"	вс 105/8",141/8",173/4",211/4",243/4",283/8",317/8",353/8",39",421/2" вр 211/4",243/4",283/8",317/8",353/8",39",421/2",495/8",563/4"
	54,5	вс 27,36,45,54,63,72,81,90,99,108 вр 54,63,72,81,90,99,108,126,144
	211/2"	вс 105/8",141/8",173/4",211/4",243/4",283/8",317/8",353/8",39",421/2" вр 211/4",243/4",283/8",317/8",353/8",39",421/2",495/8",563/4"

cassettono, optional cassetto interno
 drawer, optional inner drawer
 grand tiroir, optionnel tiroir interne
 Schubkasten, optional innere Schublade
 большой ящик, факультативно внутренний ящик

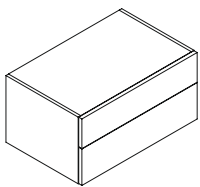
H BbIC 36,3 cm 14 1/4"	PIDIBIG	LIWIBIШ
	38,8	вс 27,36,45,54,63,72,81,90,99,108 вр 54,63,72,81,90,99,108
	151/4"	вс 105/8",141/8",173/4",211/4",243/4",283/8",317/8",353/8",39",421/2" вр 211/4",243/4",283/8",317/8",353/8",39",421/2"
	47	вс 27,36,45,54,63,72,81,90,99,108 вр 54,63,72,81,90,99,108,126,144
	181/2"	вс 105/8",141/8",173/4",211/4",243/4",283/8",317/8",353/8",39",421/2" вр 211/4",243/4",283/8",317/8",353/8",39",421/2",495/8",563/4"
	54,5	вс 27,36,45,54,63,72,81,90,99,108 вр 54,63,72,81,90,99,108,126,144
	211/2"	вс 105/8",141/8",173/4",211/4",243/4",283/8",317/8",353/8",39",421/2" вр 211/4",243/4",283/8",317/8",353/8",39",421/2",495/8",563/4"

cassetti
 drawers
 tiroirs
 Schubladen
 ящики

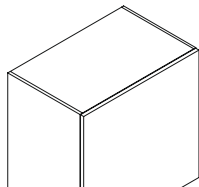
H BbIC 69,1 cm 27 1/4"	PIDIBIG	LIWIBIШ
	38,8	вс 27*,36*,45*,54,63,72 вр 54*,63,72
	151/4"	вс 105/8",141/8",173/4",211/4",243/4",283/8" вр 211/4",243/4",283/8"
	47	вс 27*,36*,45*,54,63,72,81,90,99,108 вр 54*,63,72,81,90,99,108
	181/2"	вс 105/8",141/8",173/4",211/4",243/4",283/8",317/8",353/8",39",421/2" вр 211/4",243/4",283/8",317/8",353/8",39",421/2"
	54,5	вс 27*,36*,45*,54,63,72,81,90,99,108 вр 54*,63,72,81,90,99,108
	211/2"	вс 105/8",141/8",173/4",211/4",243/4",283/8",317/8",353/8",39",421/2" вр 211/4",243/4",283/8",317/8",353/8",39",421/2"

anta o cassettono, optional cassetto interno
 door or drawer, optional inner drawer
 porte o grand tiroir, optionnel tiroir interne
 Tür und Schubkasten, optional innere Schublade
 дверка или большой ящик, факультативно внутренний ящик

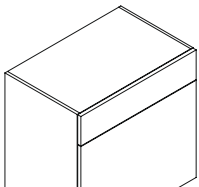
H BbIC 69,1 cm 27 1/4"	PIDIBIG	LIWIBIШ
	38,8	вс 27*,36*,45*,54,63,72 вр 54,63,72
	151/4"	вс 105/8",141/8",173/4",211/4",243/4",283/8" вр 211/4",243/4",283/8"
	47	вс 27*,36*,45*,54,63,72,81,90,99,108 вр 54,63,72,81,90,99,108
	181/2"	вс 105/8",141/8",173/4",211/4",243/4",283/8",317/8",353/8",39",421/2" вр 211/4",243/4",283/8",317/8",353/8",39",421/2"
	54,5	вс 27*,36*,45*,54,63,72,81,90,99,108 вр 54,63,72,81,90,99,108
	211/2"	вс 105/8",141/8",173/4",211/4",243/4",283/8",317/8",353/8",39",421/2" вр 211/4",243/4",283/8",317/8",353/8",39",421/2"

cassetto, anta o cassettono, optional cassetto interno
 drawer, door or drawer, optional inner drawer
 tiroir, porte o grand tiroir, optionnel tiroir interne
 Schublade, Tür oder Schubkasten, optional innere Schublade
 ящик, дверка или большой ящик, внутренний ящик

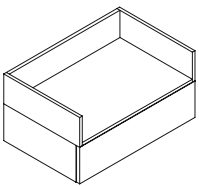
H BbIC 36,3 cm 14 1/4"	PIDIBIG	LIWIBIШ
	38,8	вс 27,36,45,54,63,72,81,90,99,108 вс 105/8",141/8",173/4",211/4",243/4",283/8",317/8",353/8",39",421/2"
	151/4"	вс 105/8",141/8",173/4",211/4",243/4",283/8",317/8",353/8",39",421/2" вс 105/8",141/8",173/4",211/4",243/4",283/8",317/8",353/8",39",421/2"
	47	вс 27,36,45,54,63,72,81,90,99,108 вс 105/8",141/8",173/4",211/4",243/4",283/8",317/8",353/8",39",421/2"
	181/2"	вс 105/8",141/8",173/4",211/4",243/4",283/8",317/8",353/8",39",421/2" вс 105/8",141/8",173/4",211/4",243/4",283/8",317/8",353/8",39",421/2"
	54,5	вс 27,36,45,54,63,72,81,90,99,108 вс 105/8",141/8",173/4",211/4",243/4",283/8",317/8",353/8",39",421/2"
	211/2"	вс 105/8",141/8",173/4",211/4",243/4",283/8",317/8",353/8",39",421/2" вс 105/8",141/8",173/4",211/4",243/4",283/8",317/8",353/8",39",421/2"

cassetto, vassoio
 drawer, tray
 tiroir, vassoio
 Schublade, vassoio
 ящик, vassoio

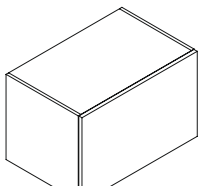
H BbIC 46,1 cm 18 1/8"	PIDIBIG	LIWIBIШ
	38,8	вс 27*,36*,45*,54,63,72,81,90,99,108 вс 54*,63,72,81,90,99,108
	151/4"	вс 105/8",141/8",173/4",211/4",243/4",283/8",317/8",353/8",39",421/2" вс 211/4",243/4",283/8",317/8",353/8",39",421/2"
	47	вс 27*,36*,45*,54,63,72,81,90,99,108 вс 54*,63,72,81,90,99,108,126,144
	181/2"	вс 105/8",141/8",173/4",211/4",243/4",283/8",317/8",353/8",39",421/2" вс 211/4",243/4",283/8",317/8",353/8",39",421/2",495/8",563/4"
	54,5	вс 27*,36*,45*,54,63,72,81,90,99,108 вс 54*,63,72,81,90,99,108,126,144
	211/2"	вс 105/8",141/8",173/4",211/4",243/4",283/8",317/8",353/8",39",421/2" вс 211/4",243/4",283/8",317/8",353/8",39",421/2",495/8",563/4"

anta o cassettono, optional cassetto interno
 door or drawer, optional inner drawer
 porte o grand tiroir, optionnel tiroir interne
 Tür und Schubkasten, optional innere Schublade
 дверка или большой ящик, факультативно внутренний ящик

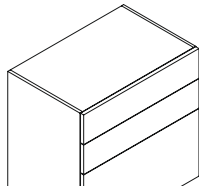
H BbIC 69,1 cm 27 1/4"	PIDIBIG	LIWIBIШ
	38,8	вс 27,36,45,54,63,72 вс 54,63,72
	151/4"	вс 105/8",141/8",173/4",211/4",243/4",283/8" вс 211/4",243/4",283/8"
	47	вс 27,36,45,54,63,72,81,90,99,108 вс 54,63,72,81,90,99,108
	181/2"	вс 105/8",141/8",173/4",211/4",243/4",283/8",317/8",353/8",39",421/2" вс 211/4",243/4",283/8",317/8",353/8",39",421/2"
	54,5	вс 27,36,45,54,63,72,81,90,99,108 вс 54,63,72,81,90,99,108
	211/2"	вс 105/8",141/8",173/4",211/4",243/4",283/8",317/8",353/8",39",421/2" вс 211/4",243/4",283/8",317/8",353/8",39",421/2"

cassetti, cassettono
 drawers, drawer
 tiroirs, grand tiroir
 Schubladen, Schubkasten
 ящики, большой ящик

H BbIC 69,1 cm 27 1/4"	PIDIBIG	LIWIBIШ
	38,8	вс 54,72,90 вс 72,90
	151/4"	вс 211/4",283/8",353/8" вс 283/8",353/8"
	47	вс 54,72,90 вс 72,90,108
	181/2"	вс 211/4",283/8",353/8" вс 283/8",353/8",421/2"
	54,5	вс 54,72,90 вс 72,90,108
	211/2"	вс 211/4",283/8",353/8" вс 283/8",353/8",421/2"

ante, optional cassetto interno
 doors, optional inner drawer
 portes, optionnel tiroir interne
 Türen, optional innere Schublade
 дверки, факультативно внутренний ящик

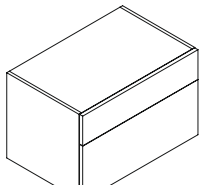
H BbIC 46,1 cm 18 1/8"	PIDIBIG	LIWIBIШ
	38,8	вс 27*,36*,45*,54,63,72,81,90,99,108 вс 54*,63,72,81,90,99,108
	151/4"	вс 105/8",141/8",173/4",211/4",243/4",283/8",317/8",353/8",39",421/2" вс 211/4",243/4",283/8",317/8",353/8",39",421/2"
	47	вс 27*,36*,45*,54,63,72,81,90,99,108 вс 54*,63,72,81,90,99,108,126,144
	181/2"	вс 105/8",141/8",173/4",211/4",243/4",283/8",317/8",353/8",39",421/2" вс 211/4",243/4",283/8",317/8",353/8",39",421/2",495/8",563/4"
	54,5	вс 27*,36*,45*,54,63,72,81,90,99,108 вс 54*,63,72,81,90,99,108,126,144
	211/2"	вс 105/8",141/8",173/4",211/4",243/4",283/8",317/8",353/8",39",421/2" вс 211/4",243/4",283/8",317/8",353/8",39",421/2",495/8",563/4"

cassetto, anta o cassettono
 drawer, door or drawer
 tiroir, porte o grand tiroir
 Schublade, Tür oder Schubkasten
 ящик, дверка или большой ящик

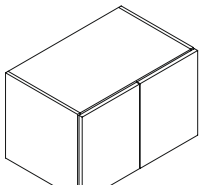
H BbIC 46,1 cm 18 1/8"	PIDIBIG	LIWIBIШ
	38,8	вс 54,72,90 вс 72,90,108
	151/4"	вс 211/4",283/8",353/8" вс 283/8",353/8",421/2"
	47	вс 54,72,90 вс 72,90,108
	181/2"	вс 211/4",283/8",353/8" вс 283/8",353/8",421/2"
	54,5	вс 54,72,90 вс 72,90,108
	211/2"	вс 211/4",283/8",353/8" вс 283/8",353/8",421/2"

ante, optional cassetto interno
 doors, optional inner drawer
 portes, optionnel tiroir interne
 Türen, optional innere Schublade
 дверки, факультативно внутренний ящи

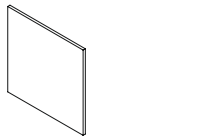
H BbIC 23,9 - 36,3 - 46,1 - 69,1cm 9 3/8" - 14 1/4" - 18 1/8" - 27 1/4"	PIDIBIG	LIWIBIШ
	38,8	1,4
	151/4"	1/2"
	47	1,4
	181/2"	1/2"
	54,5	1,4
	211/2"	1/2"

fianco di finitura
 finish side
 côté de finition
 Ausführungsseite
 боковая стенка

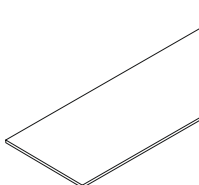
P D B G 38,8 - 47,3 - 54,8 cm 15 1/4" - 18 5/8" - 21 5/8"	LIWIBIШ
	da 54 a 288 from 211/4" to 113 3/8"
	de 54 à 288 ab 54 zu 288 от 54 до 288

top per basi sp. 1,2, 1,4, 1,5, 1,9, 2 cm
 tops for base units th. 1/2", 1/2", 5/8", 3/4", 3/4"
 plans pour meubles bas sp. 1,2, 1,4, 1,5, 1,9, 2 cm
 Schrankplatte Di. 1,2, 1,4, 1,5, 1,9, 2 cm
 столешница тол. 1,2, 1,4, 1,5, 1,9, 2 cm

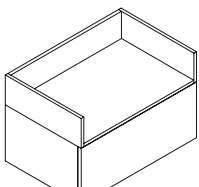
H BbIC 46,1 cm 18 1/8"	PIDIBIG	LIWIBIШ
	38,8	вс 27,36,45,54,63,72,81,90,99,108 вс 105/8",141/8",173/4",211/4",243/4",283/8",317/8",353/8",39",421/2"
	151/4"	вс 105/8",141/8",173/4",211/4",243/4",283/8",317/8",353/8",39",421/2" вс 105/8",141/8",173/4",211/4",243/4",283/8",317/8",353/8",39",421/2"
	47	вс 27,36,45,54,63,72,81,90,99,108 вс 105/8",141/8",173/4",211/4",243/4",283/8",317/8",353/8",39",421/2"
	181/2"	вс 105/8",141/8",173/4",211/4",243/4",283/8",317/8",353/8",39",421/2" вс 105/8",141/8",173/4",211/4",243/4",283/8",317/8",353/8",39",421/2"
	54,5	вс 27,36,45,54,63,72,81,90,99,108 вс 105/8",141/8",173/4",211/4",243/4",283/8",317/8",353/8",39",421/2"
	211/2"	вс 105/8",141/8",173/4",211/4",243/4",283/8",317/8",353/8",39",421/2" вс 105/8",141/8",173/4",211/4",243/4",283/8",317/8",353/8",39",421/2"

cassetto, vassoio
 drawer, tray
 tiroir, vassoio
 Schublade, vassoio
 ящик, vassoio

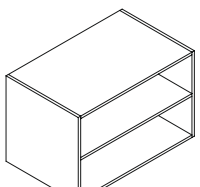
H BbIC 46,1 cm 18 1/8"	PIDIBIG	LIWIBIШ
	38,8	вс 27,36,45 вс 105/8",141/8",173/4"
	151/4"	вс 27,36,45 вс 105/8",141/8",173/4"
	47	вс 27,36,45 вс 105/8",141/8",173/4"
	181/2"	вс 27,36,45 вс 105/8",141/8",173/4"
	54,5	вс 27,36,45 вс 105/8",141/8",173/4"
	211/2"	вс 105/8",141/8",173/4" вс 105/8",141/8",173/4"

vano a giorno, ripiano
 open vanity, inner shelf
 élément à jour, étagère interne
 offenes Fach, Brett
 открытый элемент, полка

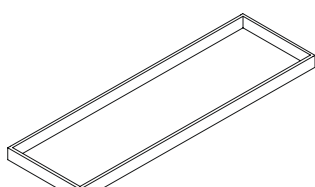
H BbIC 5 - 14,5cm 2" - 5 3/4"	PIDIBIG	LIWIBIШ
	38,8	da 27 a 288
	151/4"	from 10 5/8" to 113 3/8"
	47	de 27 à 288
	181/2"	ab 27 zu 288
	54,5	от 27 до 288
	211/2"	

zoccolo per basi
 plinth for units
 socle pour meubles
 Sockel für Möbel
 цоколь для тумб

вс base componibile | base unit | meuble bas | Einbau-Unterschrank | тумба
 вр base portalavabo | washbasin unit | meuble bas sous vasque | Waschbeckenunterschrank | тумба для раковины

* variante con anta | door version | variante avec porte | Variante mit Tür | вариант с дверкой

frontali, fianchi | fronts, sides | façades, côtés | Fronten, Seiten | фасады, боковые стенки

laccati opachi e lucidi | matt and glossy lacquers | laques mates et brillantes | Matt- und Glanzlacken | матовые-глянцевые лакировки



essenze opache | matt veneers | essences mates | matte Holze | матовые шпоны



essenza lucida | glossy veneer | essence brillante | glanzes Furnier | глянцевый шпон



laminati | laminated | mélaminés | Laminat | ламинаты



argille | clays | argiles | Lehm | глины



gola | groove handle | gorge | Griffleiste | нас

laccati opachi e lucidi | matt and glossy lacquers | laques mates et brillantes | Matt- und Glanzlacken | матовые-глянцевые лакировки



laccati anodizzati | painted anodised | laqués anodisés | Lackiert eloxiert | лакировка анодирование



top | tops | plans | Platten | столешницы

laccati opachi e lucidi, vetri | matt and glossy lacquers, glass | laques mates et brillantes, verre | Matt- und Glanzlacken, Gläser | матовые-глянцевые лакировки, стекла



essenze opache | matt veneers | essences mates | matte Holze | матовые шпоны



essenza lucida | glossy veneer | essence brillante | glanzes Furnier | глянцевый шпон

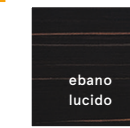

laminati | laminated | mélaminés | Laminat | ламинаты



argille | clays | argiles | Lehm | глины



sintetici | compounds | synthétiques | Kunststoff | соединений



marmi opachi | matt marbles | marbres mates | Marmor Matt | матовые мраморы

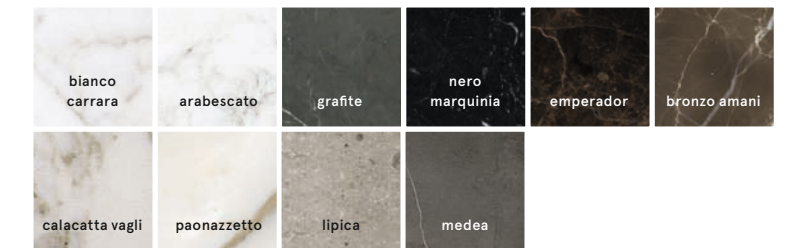

Il taglio a 45° gradi come tratto continuo tra frontali e fianchi, la gola centrale come elemento funzionale ma anche di definizione estetica dell'immagine. Zenit è la serie di contenitori sottolavabo disponibili nelle versioni a terra o sospesi per una massima versatilità funzionale e nelle finiture laccate, in essenza o argilla per la più ampia personalizzazione formale.

The 45° cutting angle plays as an unbroken line between the front and sides, the central groove as a functional element but with a markedly aesthetic connotation. Zenit is the range of vanity units available in free-standing or wall-mounted versions for maximum functional versatility, and in veneer or clay lacquered finishes for the highest degree of stylistic customization.

Un découpage à 45 degrés dessinant un trait continu entre façades et côtés, une gorge centrale devenant non seulement un élément fonctionnel mais aussi de définition esthétique : Zenit est une série d'éléments de rangement de dessous de lavabo disponibles en version sol ou suspendue une polyvalence maximale de la fonctionnalité ainsi qu'en finition laquée, essence ou argile pour une personnalisation formelle optimale.

Der Gehrungsschnitt von 45° stellt einen fließenden Übergang zwischen den Stirnseiten und den Seitenwänden dar. Die zentral angebrachte Aussparung soll nicht nur zweckdienlich sein, sondern auch zur Ästhetik des Gesamtbildes beitragen. Zenit ist eine Serie von unter dem Waschbecken angebrachten Behältnissen, die in Berücksichtigung aller Nutzungsbedürfnissen sowohl in den Versionen auf dem Fußboden aufliegend oder hängend und in der naturbelassenen oder im Farbton Argilla gehaltenen Oberflächenausführung erhältlich sind.

Сплошная линия под углом 45°, проходящая между передней панелью и боковинами, центральное углубление выполняет роль функционального элемента, усиливая при этом эстетический эффект. Zenit - это серия шкафчиков, расположенных под раковиной, в напольной или подвесной версии, с универсальными функциями, лакированной отделкой, поверхностями из дерева или терракоты, позволяя максимальную индивидуальность оформления помещения.

tipologia | type | typologie | Art | типология

gola | groove handle | gorge | Griffleiste | нас

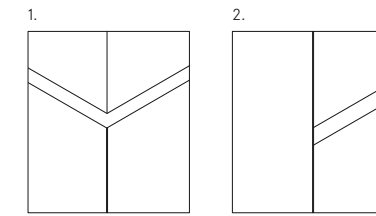

1. superiore a 45°, 2. centrale a 45°
1. upper with 45° chamfer, 2. central with 45° chamfer
1. supérieure à 45°, 2. centrale à 45°
1. Oben mit 45° Abkantung, 2. Mittlere mit 45° Abkantung
1. верхний на 45°, 2. центральный на 45°

H | BbIC 48,3 cm | 19"

PIDIBIF LIWIBIШ

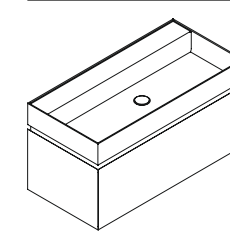

46 BP 63,90,108,126
18" 24 3/4", 35 3/8", 42 1/2", 49 5/8"

cassettone, optional cassetto interno, lavabo Man in milltek drawer, optional inner drawer, milltek washbasin Man grand tiroir, optionnel tiroir interne, vasque Man en milltek Schubkasten, optional innere Schublade, Waschbecken Man aus Milltek большой ящик, факультативно внутренний ящик, створка, раковина Man из milltek

H | BbIC 48,3 cm | 19"

PIDIBIF LIWIBIШ

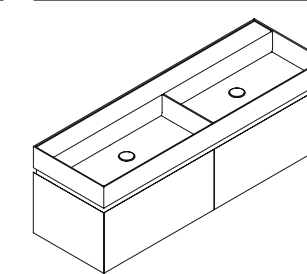

46 BP 144
18" 56 3/4"

cassettoni, optional cassetto interno, lavabo Man 144 in milltek drawers, optional inner drawer, milltek washbasin Man 144 grand tiroirs, optionnel tiroir interne, vasque Man 144 en milltek Schubkästen, optional innere Schublade, Waschbecken Man 144 aus Milltek большие ящики, факультативно внутренний ящик, створка, раковина Man 144 из milltek

H | BbIC 58,1 cm | 22 7/8"

PIDIBIF LIWIBIШ

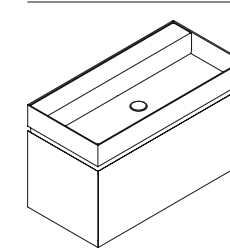

46 BP 63,90,108,126
18" 24 3/4", 35 3/8", 42 1/2", 49 5/8"

cassettone, optional cassetto interno, lavabo Man in milltek drawer, optional inner drawer, milltek washbasin Man grand tiroir, optionnel tiroir interne, vasque Man en milltek Schubkasten, optional innere Schublade, Waschbecken Man aus Milltek большой ящик, факультативно внутренний ящик, створка, раковина Man из milltek

H | BbIC 58,1 cm | 22,7"

PIDIBIF LIWIBIШ

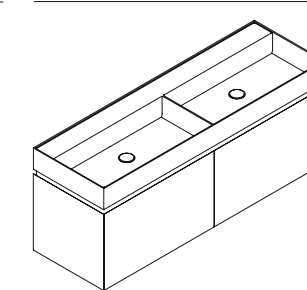

46 BP 144
18" 56 3/4"

cassettone, optional cassetto interno, lavabo Man 144 in milltek drawer, optional inner drawer, milltek washbasin Man 144 grand tiroir, optionnel tiroir interne, vasque Man 144 en milltek Schubkästen, optional innere Schublade, Waschbecken Man 144 aus Milltek большие ящики, факультативно внутренний ящик, створка, раковина Man 144 из milltek

H | BbIC 87,1 cm | 34 1/4"

PIDIBIF LIWIBIШ

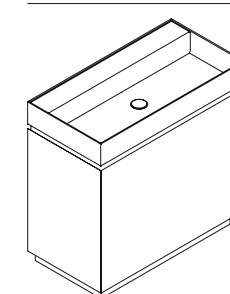

46 BP 63,90,108
18" 24 3/4", 35 3/8", 42 1/2"

cassettone, cassetto interno, lavabo Man in milltek drawer, inner drawer, milltek washbasin Man grand tiroir, tiroir interne, vasque Man en milltek Schubkasten, innere Schublade, Waschbecken Man aus Milltek большой ящик, внутренний ящик, створка, раковина Man из milltek

H | BbIC 87,1 cm | 34 1/4"

PIDIBIF LIWIBIШ

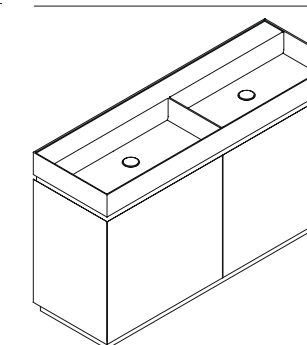

46 BP 144
18" 56 3/4"

cassettoni, cassetto interno, lavabo Man 144 in milltek drawer, inner drawer, milltek washbasin Man 144 grand tiroir, tiroir interne, vasque Man 144 en milltek Schubkästen, innere Schublade, Waschbecken Man 144 aus Milltek большие ящики, внутренний ящик, створка, раковина Man 144 из milltek

H | ВbIC 58,1 cm | 22,7"

PIDIBIG LIWIBIШ
46 BP 63,90,108,126
18" 24 3/4", 35 3/8", 42 1/2", 49 5/8"

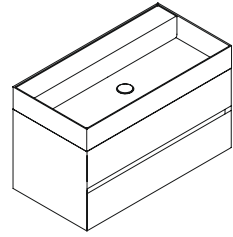

cassettoni, lavabo Man in milltek
drawers, milltek washbasin Man
grand tiroirs, vasque Man en milltek
Schubkästen, Waschbecken Man aus Milltek
большие ящики, створка, раковина Man из milltek

H | ВbIC 58,1 cm | 22,7"

PIDIBIG LIWIBIШ
46 BP 144
18" 56 3/4"

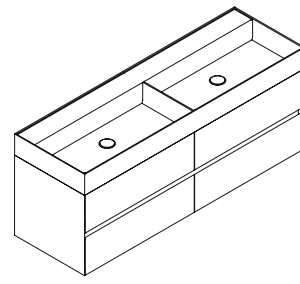

cassettoni, lavabo Man 144 in milltek
drawers, milltek washbasin Man 144
grand tiroirs, vasque Man 144 en milltek
Schubkästen, Waschbecken Man 144 aus Milltek
большие ящики, створка, раковина Man 144 из milltek

H | ВbIC 87 cm | 34 1/4"

PIDIBIG LIWIBIШ
46 BP 63,90,108,126
18" 24 3/4", 35 3/8", 42 1/2", 49 5/8"

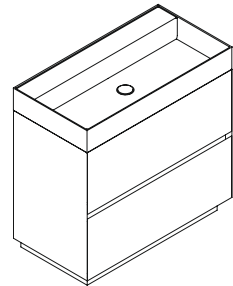

cassettoni, lavabo Man in milltek
drawers, milltek washbasin Man
grand tiroirs, vasque Man en milltek
Schubkästen, Waschbecken Man aus Milltek
большие ящики, створка, раковина Man из milltek

H | ВbIC 87 cm | 34 1/4"

PIDIBIG LIWIBIШ
46 BP 144
18" 56 3/4"

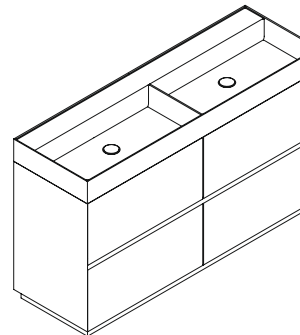

cassettoni, lavabo Man 144 in milltek
drawers, milltek washbasin Man 144
grand tiroirs, vasque Man 144 en milltek
Schubkästen, Waschbecken Man 144 aus Milltek
большие ящики, створка, раковина Man 144 из milltek

frontali, fianchi, gola | fronts, sides, groove | façades, côtés, gorge | Fronten, Seiten, Griffleiste | фасады, боковые стенки, паз

laccati opachi e lucidi | matt and glossy lacquers | laques mates et brillantes | Matt- und Glanzlacken
матовые-глянцевые лакировки



essenze opache | matt veneers | essences mates | matte Holze | матовые шпоны



essenza lucida | glossy veneer | essence brillante | glanzes Furnier | глянцевый шпон

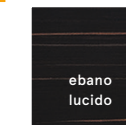

argille | clays | argiles | Lehm | глины



lavabo | washbasin | vasque | Waschbecken | раковина

synthetic | compounds | synthétiques | Kunststoff | соединений



TOUCH

TECHNICAL

Un lavabo monolitico dall'estetica minimale capace di conferire identità e personalità anche a spazi di piccole dimensioni. Touch stupisce per l'estrema compattezza che nasconde una straordinaria funzionalità ma anche per l'ampia varietà di finiture che impreziosiscono le sue superfici: dalle laccature alle essenze naturali, fino alle argille. Una proposta dall'impronta contemporanea, dal forte valore scultoreo accentuato dalla combinazione con le specchiere dotate di illuminazione led integrata.

A single-block washbasin with strikingly minimal aesthetics yet capable of conferring identity and character even to smaller spaced interiors. Touch is a real surprise with its extreme compactness that belies an uncommon knack for functionality, as well as its wide range of surface-enhancing finishes: whether lacquers, natural veneer varieties, or clays. A decor proposal with a markedly contemporary feel, and a strong sculptural value underscored by the addition of mirrors with integrated LED lighting.

Ce lavabo monolithe d'apparence minimaliste est en mesure de conférer identité et caractère même aux petits espaces. Touch surprend par son extrême compacité qui ne préjudicie en rien sa fonctionnalité ainsi que par la richesse des finitions sublimant ses surfaces : des laquages aux essences naturelles en passant par les argiles. Un produit de style contemporain se distinguant par son aspect particulièrement sculptural, en particulier quand il est associé avec les miroirs à éclairage led intégré.

Aus einem Monolithen gefertigtes Waschbecken, deren Ästhetik auf einer sich aufs Wesentliche beschränkenden Gestaltung beruht und auch kleinen Räumen zu Ausdruckstärke und einer ganz persönlichen Note verhilft. Touch erstaunt durch seine Kompaktheit, hinter der sich eine außerordentliche Funktionalität verbirgt und durch seine Vielzahl an edlen Oberflächenausführungen: von der Lackierung mit natürlichen Essenzen bis zu Ausführungen mit Lehm. Eine Gestaltungslösung von zeitgenössischem Gepräge, die eine große Wirkung zeigt, die durch die Kombination mit Led-beleuchteten Wandspiegeln noch verstärkt wird.

Монолитная раковина с минимальной эстетикой, способная придать индивидуальность и личный стиль даже самым маленьким помещениям. Touch поражает необычайной компактностью форм, скрывающих повышенную функциональность, и обширной гаммой отделок, украшающих поверхности: лакированные натуральные деревянные поверхности, глина. Эта коллекция отличается выраженной современностью решений, скульптурными формами, подчеркиваемыми сочетанием с зеркалами, оборудованными встроенной диодной подсветкой.

fniture | finishes | finitions | Oberflächen | отделки

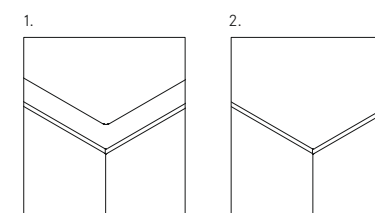

1. lavabo milltek, 2. fianchi, frontali, lavabo Full in marmo
1. milltek washbasin, 2. marble fronts, sides, washbasin mod. Full in marble
1. vasque en milltek, 2. façades, côtés, vasque mod. Full en marbre
1. Waschbecken aus Milltek, 2. Fronten, Seiten, Becken Full aus Marmore
1. раковина из milltek, 2. фасады, боковые стенки, раковина мод. Full из мраморы

tipologia | type | typologie | Art | типология

push-pull | push-latch | loqueteau push-pull | Touch-System | нажимная защелка

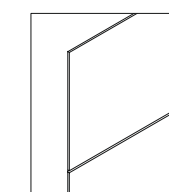

cassetti push pull, anta push latch drawers, door tiroir loqueteau push-pull, porte Schubladen Touch-System, Tür ящички нажимная защелка, дверки

H | BxL 88 cm | 34 5/8"

PIDIBIG LIWIBISH

40,3 VP 41,3
15 7/8" 16 1/4"

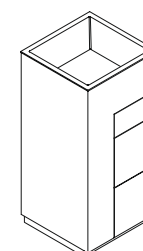

cassetto, cassettone, anta, lavabo Full 41 in milltek o marmo
drawer, drawer, door, milltek or marble washbasin Full 41
tiroir, grand tiroir, porte, vasque Full 41 en milltek ou marbres
Schublade, Schubkasten, Tür, Waschbecken Full 41 aus Milltek oder Marmore
ящик, большой ящик, створка, раковина Full 41 из milltek или мраморы

H | BxL 88 cm | 34 5/8"

PIDIBIG LIWIBISH

40,3 VP 64,3
15 7/8" 25 3/8"

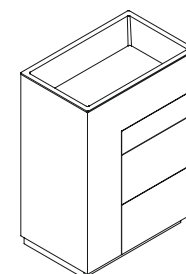

cassetto, cassettone, anta, lavabo Full 64 in milltek o marmo
drawer, drawer, door, milltek or marble washbasin Full 64
tiroir, grand tiroir, porte, vasque Full 64 en milltek ou marbres
Schublade, Schubkasten, Tür, Waschbecken Full 64 aus Milltek oder Marmore
ящик, большой ящик, створка, раковина Full 64 из milltek или мраморы

H | BxL 88 cm | 34 5/8"

PIDIBIG LIWIBISH

40,3 VP 64,3
15 7/8" 25 3/8"

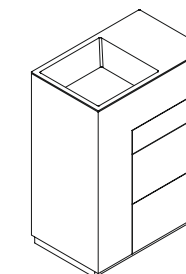

cassetto, cassettone, anta, lavabo Short 64 in milltek
drawer, drawer, door, milltek washbasin Short 64
tiroir, grand tiroir, porte, vasque Short 64 en milltek
Schublade, Schubkasten, Tür, Waschbecken Short 64 aus Milltek
ящик, большой ящик, створка, раковина Short 64 из milltek

H | BxL 88 cm | 34 5/8"

PIDIBIG LIWIBISH

40,3 VP 100,3
15 7/8" 39 1/2"

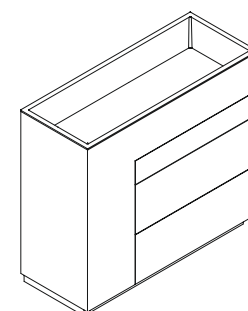

cassetto, cassettone, anta, lavabo Full 100 in milltek o marmo
drawer, drawer, door, milltek or marble washbasin Full 100
tiroir, grand tiroir, porte, vasque Full 100 en milltek ou marbres
Schublade, Schubkasten, Tür, Waschbecken Full 100 aus Milltek oder Marmore
ящик, большой ящик, створка, раковина Full 100 из milltek или мраморы

H | BxL 88 cm | 34 5/8"

PIDIBIG LIWIBISH

40,3 VP 100,3
15 7/8" 39 1/2"

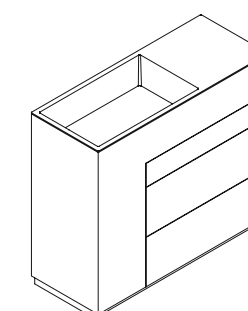

cassetto, cassettone, anta, lavabo Short 100 in milltek
drawer, drawer, door, milltek washbasin Short 100
tiroir, grand tiroir, porte, vasque Short 100 en milltek
Schublade, Schubkasten, Tür, Waschbecken Short 100 aus Milltek
ящик, большой ящик, створка, раковина Short 100 из milltek

H | ВbC 88 cm | 34 5/8"

PIDIBIG LIWIBIШ

48,3 41,3
19" 16 1/4"

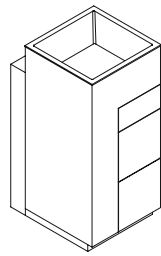

cassetto, cassettone, anta, lavabo Full 41 in milltek o marmo, distanziale
drawer, drawer, door, milltek or marble washbasin Full 41, spacer
tiroir, grand tiroir, porte, vasque Full 41 en milltek ou marbres, entretoise
Schublade, Schubkasten, Tür, Waschbecken Full 41 aus Milltek oder Marmore, abstandhalter
ящик, большой ящик, створка, раковина Full 41 из milltek или мраморы, проставка

H | ВbC 88 cm | 34 5/8"

PIDIBIG LIWIBIШ

48,3 64,3
19" 25 3/8"

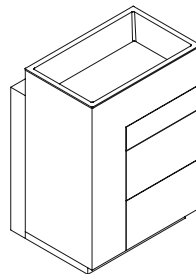

cassetto, cassettone, anta, lavabo Full 64 in milltek o marmo, distanziale
drawer, drawer, door, milltek or marble washbasin Full 64, spacer
tiroir, grand tiroir, porte, vasque Full 64 en milltek ou marbres, entretoise
Schublade, Schubkasten, Tür, Waschbecken Full 64 aus Milltek oder Marmore, abstandhalter
ящик, большой ящик, створка, раковина Full 64 из milltek или мраморы, проставка

H | ВbC 88 cm | 34 5/8"

PIDIBIG LIWIBIШ

48,3 64,3
19" 25 3/8"

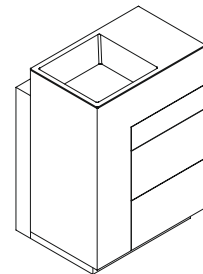

cassetto, cassettone, anta, lavabo Short 64 in milltek o marmo, distanziale
drawer, drawer, door, milltek or marble washbasin Short 64, spacer
tiroir, grand tiroir, porte, vasque Short 64 en milltek ou marbres, entretoise
Schublade, Schubkasten, Tür, Waschbecken Short 64 aus Milltek oder Marmore, abstandhalter
ящик, большой ящик, створка, раковина Short 64 из milltek или мраморы, проставка

H | ВbC 88 cm | 34 5/8"

PIDIBIG LIWIBIШ

48,3 100,3
19" 39 1/2"

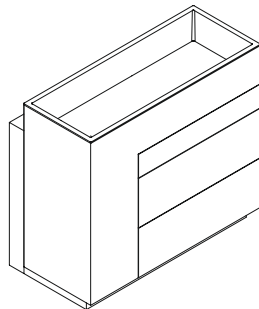

cassetto, cassettone, anta, lavabo Full 100 in milltek o marmo, distanziale
drawer, drawer, door, milltek or marble washbasin Full 100, spacer
tiroir, grand tiroir, porte, vasque Full 100 en milltek ou marbres, entretoise
Schublade, Schubkasten, Tür, Waschbecken Full 100 aus Milltek oder Marmore, abstandhalter
ящик, большой ящик, створка, раковина Full 100 из milltek или мраморы, проставка

H | ВbC 88 cm | 34 5/8"

PIDIBIG LIWIBIШ

48,3 100,3
19" 39 1/2"

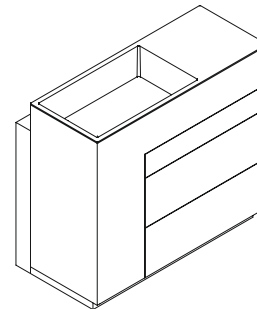

cassetto, cassettone, anta, lavabo Short 100 in milltek o marmo, distanziale
drawer, drawer, door, milltek or marble washbasin Short 100, spacer
tiroir, grand tiroir, porte, vasque Short 100 en milltek ou marbres, entretoise
Schublade, Schubkasten, Tür, Waschbecken Short 100 aus Milltek oder Marmore, abstandhalter
ящик, большой ящик, створка, раковина Short 100 из milltek или мраморы, проставка

BP base portalavabo | washbasin unit | meuble bas sous vasque | Waschbeckenunterschrank | тумба для раковины

frontali, fianchi | fronts, sides | façades, côtés | Fronten, Seiten | фасады, боковые стенки

laccati opachi | matt lacquers | laques mates | Mattlacke | матовые лакировки

argille | clays | argiles | Lehm | глины



essenze opache | matt veneers | essences mates | matte Holze | матовые шпоны



abete | fir | sapin | Tanne | бе́реза



lavabo | washbasin | vasque | Waschbecken | раковина

synthetic | compounds | synthétiques | Kunststoff | соединений

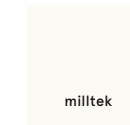

frontali, fianchi, lavabo | fronts, sides, washbasin | façades, côtés, vasque | Fronten, Seiten, Waschbecken | фасады, боковые стенки, раковина

marmi opachi | matt marbles | marbres mates | Marmor Matt | матовые мраморы

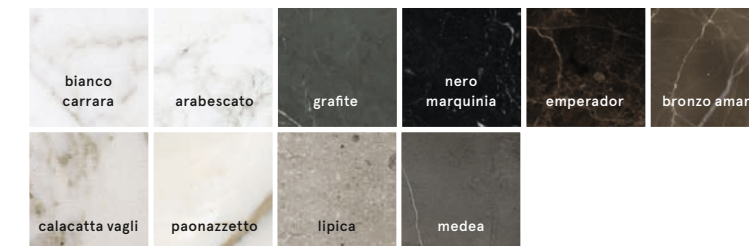

Forme sinuose, concave o convesse per dar vita a volumi avvolgenti dalla perfetta ergonomia, contenitori che si compenetrano per dar luogo a configurazioni inedite, piani lavabo dalla forma esclusiva, maniglie integrate per non interrompere il profilo della composizione e specchi con lampade che si sovrappongono in parte ponendo luci d'accento. Simy è un insieme di dettagli e di linee che danno vita a soluzioni evolute che riescono a concentrare tutte le funzioni in uno spazio organico e contenuto.

Supple, dipped or rounded forms give life to wrap-around volumes shaped by perfectly applied ergonomics; containers that merge into one another to give rise to novel arrangements; uniquely shaped washbasins; integrated door handles so as not to break the flow of composition, and mirrors with partly overlapping lamps throwing sophisticated accent lighting. Simy is a set of fine details and lines that create advanced solutions capable of concentrating all its functions into an organic, compact space.

Des formes sinueuses, concaves ou convexes pour donner naissance à de chaleureux volumes parfaitement ergonomiques. Des éléments de rangement qui s'interpénètrent pour générer des configurations inédites. Des plans de lavabo aux formes uniques. Des poignées intégrées pour ne pas interrompre le profil de la composition. Et enfin des miroirs dont les lampes se superposent partiellement pour devenir des éclairages ciblés. Simy est un ensemble de lignes et de détails qui donne naissance à des solutions évoluées parvenant à concentrer toutes les fonctions dans un espace organique et réduit.

Geschwungene, konkave oder konvexe Formen aus denen ergonomisch perfekte Raumelemente, Behältnisse neuer unbekannter Erscheinungsformen, Ablagen für Waschbecken von exklusiver Form, integrierte, die Gleichförmigkeit des Profils des Einbaus nicht beeinträchtigende Türgriffe und Spiegel mit zum Teil überlagerten besondere Lichteffekte erzeugenden Leuchten, das ist Simy, eine Verschmelzung von Details und Linien, die fortschrittliche Lösungen ermöglichen, deren Funktionalität sich auch in einer Umgebung von beschränkter Größe voll entfaltet.

Гибкие формы, выпуклые или вогнутые, дают жизнь обтекающим объемам, обладающим безупречной эргономикой, шкафчики, соединенные друг с другом, создавая при этом совершенно новые и необычные формы, столешницы раковин эксклюзивной формы, встроенные ручки, не нарушающие профиль композиции и зеркала с лампами, находящимися сверху и подчеркивающими красоту освещением. Simy - это совокупность деталей и линий, дающих жизнь продвинутым решениям, способным сконцентрировать различные функции в органичном и небольшом пространстве.

tipologia | type | typologie | Art | типология
maniglia | handles | poignées | Handgriffe | ручки

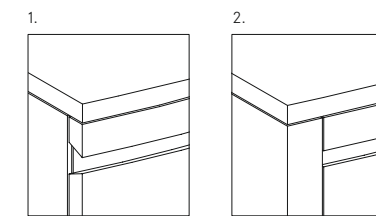

1. top, 2. top e fianchi di finitura
1. top, 2. top and finish sides
1. plan chanfrein, 2. plan et côtés de finition
1. Platte, 2. Platte und Ausführungsseiten
1. столешница, 2. столешница и боковые стенки

H | ВbIC 43 cm | 16 7/8"

PIDIBIG 38,8 - 54,5
15 1/4" - 21 1/2"

LIWIBISH BP 72
28 3/8"

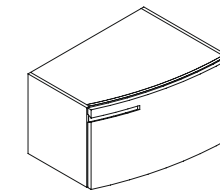

cassettone
drawer
grand tiroir
Schubkasten
большой ящик

H | ВbIC 43 cm | 16 7/8"

PIDIBIG 38,8 - 51,6
15 1/4" - 21 1/2"

LIWIBISH BP 99
39"

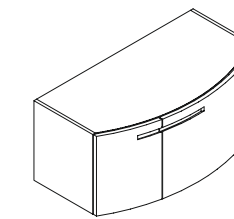

anta, cassettone
door, drawer
porte, grand tiroir
Tür, Schubkasten
дверка, большой ящик

H | ВbIC 43 cm | 16 7/8"

PIDIBIG 23 - 54,5
9" - 21 1/2"

LIWIBISH BP 108
42 1/2"

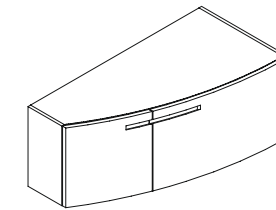

anta, cassettone
door, drawer
porte, grand tiroir
Tür, Schubkasten
дверка, большой ящик

H | ВbIC 43 cm | 16 7/8"

PIDIBIG 7,5 - 54,5
3" - 21 1/2"

LIWIBISH BP 130
51 1/8"

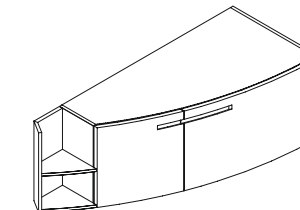

anta, cassettone, vano a giorno
door, drawer, open unit
porte, grand tiroir, niche ouverte
Tür, Schubkasten, offenes Fach
дверка, большой ящик, открытый элемент

H | BxIc 43 cm | 16 7/8"

PIDIBIG LIWIBIШ

23 - 38,8 - 51,6 BP 126
9" - 15 1/4" - 20 3/8" 49 5/8"

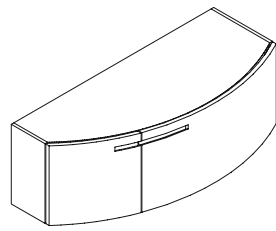

anta, cassettone
door, drawer
porte, grand tiroir
Tür, Schubkasten
дверка, большой ящик

H | BxIc 43 cm | 16 7/8"

PIDIBIG LIWIBIШ

38,8 - 54,5 BP 144
15 1/4" - 21 1/2" 56 3/4"

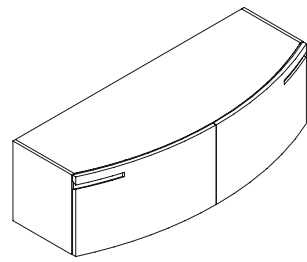

cassettoni
drawers
grand tiroirs
Schubkästen
большие ящики

H | BxIc 43 cm | 16 7/8"

PIDIBIG LIWIBIШ

16,7 - 38,8 - 54,5 BP 180
6 5/8" - 15 1/4" - 21 1/2" 70 7/8"

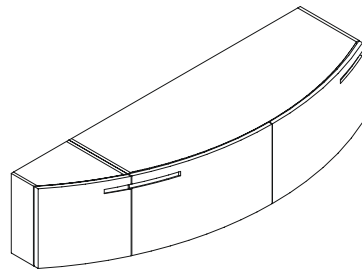

ante, cassettoni
doors, drawers
portes, grand tiroirs
Türen, Schubkästen
дверка, большие ящики

H | BxIc 43 cm | 16 7/8"

PIDIBIG LIWIBIШ

16,7 - 54,5 BP 216
6 5/8" - 21 1/2" 85"

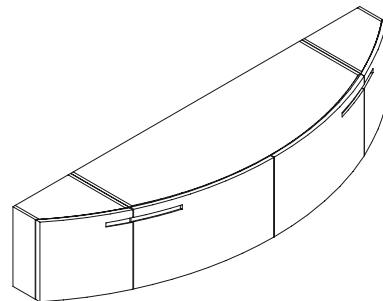

ante, cassettoni
door, drawers
porte, grand tiroirs
Türen, Schubkästen
дверка, большие ящики

H | BxIc 43 cm | 16 7/8"

PIDIBIG LIWIBIШ

23* BC 27,36,45
9** 105/8", 14 1/8", 17 3/4"
38,8 BC 27,36,45
15 1/4" 105/8", 14 1/8", 17 3/4"
54,5 BC 27,36,45
21 1/2" 105/8", 14 1/8", 17 3/4"

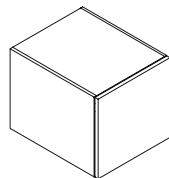

anta* o cassettone, optional cassetto interno
door* or drawer, optional inner drawer
porte* o grand tiroir, optionnel tiroir interne
Tür* und Schubkasten, optional innere Schublade
дверка или большой ящик, факультативно внутренний ящик

H | BxIc 43 cm | 16 7/8"

PIDIBIG LIWIBIШ

23 2,5
9" 1"
38,8 4,5
15 1/4" 13/4"
54,5 5
21 1/2" 2"

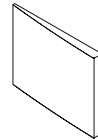

fianco di finitura
finish side
côté de finition
Ausführungsseite
боковая стенка

PIDIBIG 17 - 39,2 - 55 cm | 6 3/4" - 15 3/8" - 21 5/8"

LIWIBIШ

da 99 a 288
from 39" to 113 3/8"
de 99 à 288
ab 99 zu 288
от 99 до 288

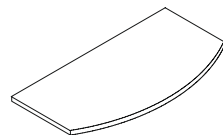

top per portalavabo sp. 1,5 - 1,9 - 2 cm
tops for washbasin units th. 5/8" - 3/4"
plans pour meubles bas sous vasque ép. 1,5 - 1,9 - 2 cm
Schränkplatte Di. 1,5 - 1,9 - 2 cm
столешница тол. 1,5 - 1,9 - 2 cm

PIDIBIG 7,3 - 23,6 - 39,2 - 52 - 55 cm | 2 7/8" - 9 1/4" - 15 3/8" - 20 1/2" - 21 5/8"

LIWIBIШ

da 72 a 288
from 28 3/8" to 113 3/8"
de 72 à 288
ab 72 zu 288
от 72 до 288

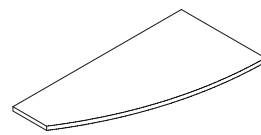

top per portalavabo sp. 1,5 - 1,9 - 2 cm
tops for washbasin units th. 5/8" - 3/4"
plans pour meubles bas sous vasque ép. 1,5 - 1,9 - 2 cm
Schränkplatte Di. 1,5 - 1,9 - 2 cm
столешница тол. 1,5 - 1,9 - 2 cm

frontali, fianchi | fronts, sides | façades, côtés | Fronten, Seiten | фасады, боковые стенки

laccati opachi e lucidi | matt and glossy lacquers | laques mates et brillantes | Matt- und Glanzlacken | матовые-глянцевые лакировки,



essenze opache | matt veneers | essences mates | matte Holz | матовые шпоны



essenza lucida | glossy veneer | essence brillante | glanzes Furnier | глянцевый шпон

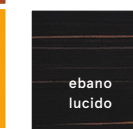

top | tops | plans | Platte | столешницы

vetri | glasses | verres | Gläser | стекла



marmi opachi | matt marbles | marbres mates | Marmor Matt | матовые мраморы

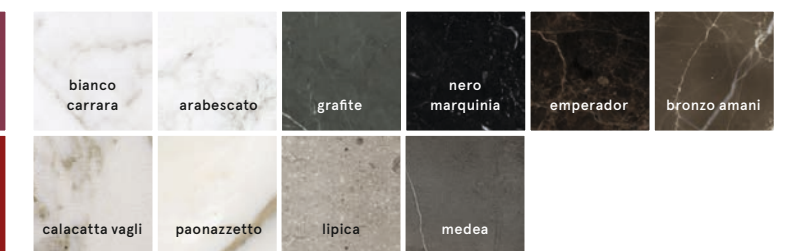

simetici | compounds | synthétiques | Kunststoff | соединений

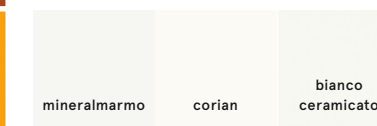

BC base componibile | base unit | meuble bas | Einbau-Unterschrank | тумба
BP base portalavabo | washbasin unit | meuble bas sous vasque | Waschbeckenunterschrank | тумба для раковины

* variante con anta | door version | variante avec porte | Variante mit Tür | вариант с дверкой

art direction

Paolo Mojoli

graphic design

Juma

photo

ContrattiCompany

styling

Juma

photo studio, set assistant

Ottonove

Collages p. 7, 35, 65, 178

Juma

editing

Davide Cattaneo

prepress

Luce Group

printing

Optima

printed in Italy

september 2016

thank to

FontanaArte

Nasomatto

Milldue spa si riserva il diritto di apportare modifiche migliorative al prodotto in qualsiasi momento e senza preavviso. I campioni dei materiali sono a carattere puramente indicativo. I Milldue reserves the right to apply improving changes to the products at any time without prior notice. The samples are purely indicative. I Milldue se réserve le droit d'apporter modifications pour l'amélioration du produit, à n'importe quel moment et sans préavis. Les échantillons sont à caractère purement indicatif. I Milldue spa behält sich das Recht vor, zweckmäßige verbessernde Änderungen der Produkte ohne Voranmeldung vorzunehmen. Die Muster sind unverbindlich. I Milldue оставляет за собой право в любой момент и без предупреждения усовершенствовать характеристики своих изделий. Образцы имеют исключительно ориентировочное значение.

**noorth**

marchio registrato
registred trademark
marque déposée
eingetragene Marke
заводская марка

milldue

MILLDUE SPA
via Balegante, 7 – 31039 Riese Pio X – Treviso, Italy
tel +39 0423.756611 – fax +39 0423.756699
exp. dept. +39 0423.756622 – fax +39 0423.756699
www.milldue.com | milldue@milldue.com

