

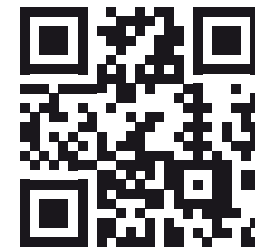

MIE
ANDMY
HOME

MisuraEmme®



WWW.MISURAEEMME.IT

MisuraEmme®

INTERIOR INSPIRATION 01

RIGORE E PUREZZA, DESIGN CONTEMPORANEO E FUNZIONALITÀ.
UN CONNUBIO PERFETTO DAL QUALE SCATURISCE UNA NUOVA
ESTETICA DEL VIVERE ODIERNO CAPACE DI SCANDIRE CON
ARMONIA ENCOMIABILE I LUOGHI DELL'ABITARE. GEOMETRIE
LINEARI E VOLUMI SCULTOREI MODULANO LO SPAZIO DIVENTATO
A MISURA DI SÉ, PALCOSCENICO IN CUI L'IMPERATIVO DELLA
QUALITÀ, L'INNOVAZIONE E L'ATTENZIONE AI DETTAGLI DIVENTANO
I RAPPRESENTANTI DI UN GLAMOUR E UN FASCINO SENZA TEMPO.

PRECISION, PURITY, CONTEMPORARY DESIGN AND FUNCTIONALITY. A
PERFECT COMBINATION THAT GIVES RISE TO A NEW CONTEMPORARY
LIFESTYLE AESTHETIC THAT LENDS REMARKABLE HARMONY TO LIVING
ENVIRONMENTS. LINEAR GEOMETRY AND SCULPTURAL VOLUMES
MODULATE SPACE THAT HAS BECOME SELF-DEFINING, A STAGE
ON WHICH HIGH QUALITY, INNOVATION AND ATTENTION TO DETAIL
REPRESENT GLAMOR AND TIMELESS CHARM.







Sistema giorno **Over**: dettaglio dei cassetti rivestiti in Tecno-Marble Grey Stone.



Day system **Over**: details of drawers covered in Tecno-Marble Grey Stone.

In queste pagine e nelle pagine precedenti: sistema giorno **Over** in essenza Olmo Grey con inserti su schienali, spalle e cassetti in Tecno-Marble Grey Stone. Ripiani in estruso di alluminio rivestiti in pelle. Inserimento luci LED sotto ripiano con sistema di illuminazione innovativo per boiserie orizzontale. Divani **Phoenix** rivestiti in pelle con cuscini in velluto e pelle scamosciata. Poltrone **Violetta** in cuoio e tessuto, base in metallo Canna di Fucile. Tavolini **Kessler** piano in vetro riflettente Fumé, base metallo Canna di Fucile. Tavolino **Gramercy** piano vetro trasparente Fumé, base in massello finitura essenza Olmo Grey.

In these pages and on the previous pages: **Over** day system in veneer finishing Elm Grey with inserts of Tecno-Marble Grey Stone into the back panels, side panels and over the drawers. Shelves made of extruded aluminum covered with leather. Led lights inserted under the shelves. **Phoenix** sofa covered in leather, small cushions in velvet and suede. **Violetta** armchair in thick leather and fabric. Swivelling base in metal finish Gun Metal. Low tables **Kessler** in reflective glass Fumé, base in metal finish Gun Metal. Small table **Gramercy**, top in transparent glass Fumé, base in solid wood Elm Grey.



Sotto: dettaglio del ripiano in estruso di Alluminio, finitura pelle con raffinata cucitura a vista. A destra: sistema giorno **Over** dove i dettagli fanno la differenza, dettaglio delle spalle con inserti di Tecno-Marble Grey Stone.



Above: shelf detail in extruded aluminum, leather finish, close up on the refined visible stitching. Right: **Over** system day, a project where details make the difference, side panels detail with inserts of Tecno-Marble Grey Stone.



Poltroncina **Violetta** con rivestimento interno in tessuto, esterno in cuoio. Base girevole in metallo con finitura Canna di Fucile. Tavolino **Kessler** con piano in vetro riflettente Fumé.



Violetta arm chair covered inside in fabric and outside in thick leather. Swivelling base in metal finish Gun Metal. Small table **Kessler** with top reflective glass Fumé.

Poltrona **Violetta**: dettaglio dello schienale in cuoio con raffinata cucitura a vista.



Violetta armchair: detail of the thick leather back side and of the refined visible stitching.







Nelle pagine precedenti: divano **Phoenix** rivestito in pelle. Tavolino basso **Janus** base in metallo verniciato nero con inserti nichelati oro, piano in Calacatta Oro. Tavolino **Kessler** base metallo, piano in vetro riflettente Fumé. Tavolino **Moai**, elemento cilindrico in massello laccato lucido. Sotto: particolare delle eleganti cuciture.



On the previous pages: **Phoenix** sofa covered in leather. Low table **Janus** black varnished metal base with gold nickel inserts, top in marble Calacatta Oro. **Kessler** small table, top in reflective glass fumé. Small table **Moai**, a cylindric element in solid wood, glossy lacquered. Above: detail of the elegant stitching.



In queste pagine: grande leggerezza formale per l'armadio coplanare **Palo Alto** basato su un fianco telaio portante. Luci LED inserite verticalmente in una apposita sede nel telaio. Piani in vetro inseriti in una cornice di metallo verniciato Canna di Fucile. Ripiani inclinati porta scarpe, nella stessa finitura della struttura. Maniglia **Narcisse**.

On these pages: great formal lightness for the coplanar wardrobe **Palo Alto** based on an aluminum side with self-bearing frame. Vertical LED lights inserted in a special site, in the uprights. Glass shelves aluminum frame, Gun Metal finish. Slanted shoes shelves in the same finish of the structure. **Narcisse** handle.



A destra: particolare delle ante scorrevoli complanari aperte, lo schienale in specchio riflettente trasmette una sensazione di maggiore profondità visiva. Sotto: particolare del vassoio estraibile con elementi divisori asportabili, ripiano rivestito in ecopelle.



Right: detail of the opened coplanar sliding doors. The reflective mirror back panel allows a highest depth perception. Above: detail of the pull-out tray with internal divider, top covered in ecop leather.







A sinistra: comodino **Milvian** con cassetto in essenza Rovere Nero nella stessa finitura della struttura, spalle in alluminio verniciato Bronzo, top in marmo Calacatta Oro, piano di appoggio superiore in vetro trasparente Fumé. Sotto: dettaglio della spalla sagomata.



Left: **Milvian** bedside table with drawer, Oak Black veneer in the same finish as the structure, sides in varnished Bronze aluminum, top in Calacatta Oro marble, upper top in transparent glass Fumé. Above: detail of the shaped side.





In queste pagine e in quelle precedenti: letto **Nice** con testata rivestita in pelle e struttura in pelle scamosciata, l'accostamento di diversi materiali mette in risalto le qualità del prodotto. Poltroncine **Surface** rivestite in tessuto. Tavolino **Janus** base metallo verniciato nero con particolari nichelati oro, piano in marmo Marquinia. Comodini **Milvian** in due diverse misure. Composizione a destra: sistema giorno **Crossing**, struttura laccato opaco Grigio Lava, schienali in essenza Rovere Cenere e Tecno-Marble, raster sp.14 mm laccato opaco Grigio Lava, elemento integrato **Palo Alto** con ante **Teka** in vetro grigio Fumé, fianchi telaio con vetro trasparente Fumé, luce LED Zaffiro, ripiani vetro trasparente Fumé. Composizione **Crossing** a sinistra: stesse caratteristiche con anta ribalta "Bar".

On these pages and in the previous: **Nice** bed leather covered headboard, structure in suede, the matching of different materials underlines the product aesthetic qualities. **Surface** armchair with fabric cover. **Janus** coffee table metal base black varnished with nickel-plated gold inserts, top in Marquinia marble. **Milvian** bedside tables in two different dimensions. Right composition: **Crossing** matt lacquered Grigio Lava structure finishing, backs in Oak Cenere wood and Tecno-Marble, raster 14 mm thick matt lacquered Grigio Lava, integrated element **Palo Alto** with **Teka** doors in transparent glass, uprights with transparent glass Fumé, Zaffiro LED light, grey Fumé glass shelves. **Crossing** composition: same characteristics for the composition with "Bar" flap down door.



Nelle pagine successive: comò **Milvian** con cassetti e struttura in essenza Rovere Nero, top in marmo Marquinia, spalle sagomate in alluminio verniciato Canna di Fucile. Sotto: dettaglio spalla sagomata e top in marmo del comò **Milvian**. A destra: armadio sistema **Palo Alto** con ante **London** in pelle scamosciata con raffinate cuciture a vista, sistema contenitori **Maggie** integrato e cassettini in cuoio con luci LED.

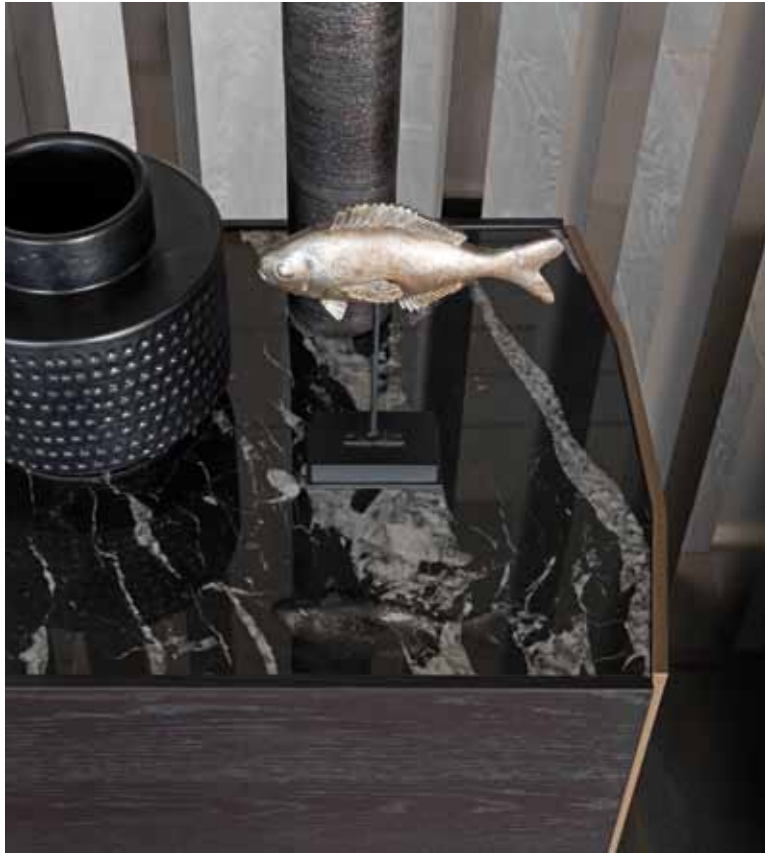

On the following pages: **Milvian** chest of drawers in eneered Oak Black finish and drawers in the same finish as the structure, Marquinia marble top, shaped sides in aluminum varnished Gun Metal. Above: detail of the shaped side and top in Marble. On the right: wardrobe **Palo Alto** system with **London** doors suede covered with refined visible stitchings, **Maggie** system integrated with thick leather drawers and LED lights.





Cabina **Palo Alto** con ante, schienali e spalle terminali in vetro trasparente naturale, finitura fianchi telai e profili in metallo Canna di Fucile, cassettiere sospese con top in ecopelle, ripiani in vetro montati su telaio in alluminio finitura Canna di Fucile. Armadio sistema **Palo Alto** con ante **London** in pelle scamosciata, sistema contenitori **Maggie** integrato composto da teche, vani a giorno in legno e vetro, cassetтини svuota tasche in cuoio, luci LED.

Palo Alto system with doors, back panels and end panels in transparent glass Natural, side profiles and frame in aluminum Gun Metal finish. Suspended chest of drawers with top in ecoleather. **Maggie** integrated container system, consisting of display cases in wood and glass with small drawers in thick-leather, LED lights.



Sotto: tavolino **Janus** base leggermente arrotondata in metallo verniciato e piano in marmo Marquinia.
A destra: tavolino **Janus** e poltroncina **Surface** rivestita in tessuto.



Above: **Janus** small table with slightly rounded base in varnished metal and Marquinia marble top. On right: **Janus** small table and **Surface** armchair covered in fabric.





Dettaglio composizione **Crossing** con ante **Teka**, schienali in Tecno-Marble, elemento integrato **Palo Alto** con ante **Teka**, fianchi telaio e ripiani in vetro trasparente Fumé, luce LED Zaffiro. A destra: particolare della scarpiera con interno in nobilitato Shantung di seta; luci LED integrate nei montanti e nel sottopiano.



Detail of **Crossing** composition with **Teka** doors, back panel in Tecno-Marble, integrated element **Palo Alto** with **Teka** glass doors, frame sides and shelves in transparent glass Fumé, Zaffiro LED light. Right: detail of the shoe-rack element, internal structure in Shantung di seta melamine; LED lights built into the uprights and under shelves.



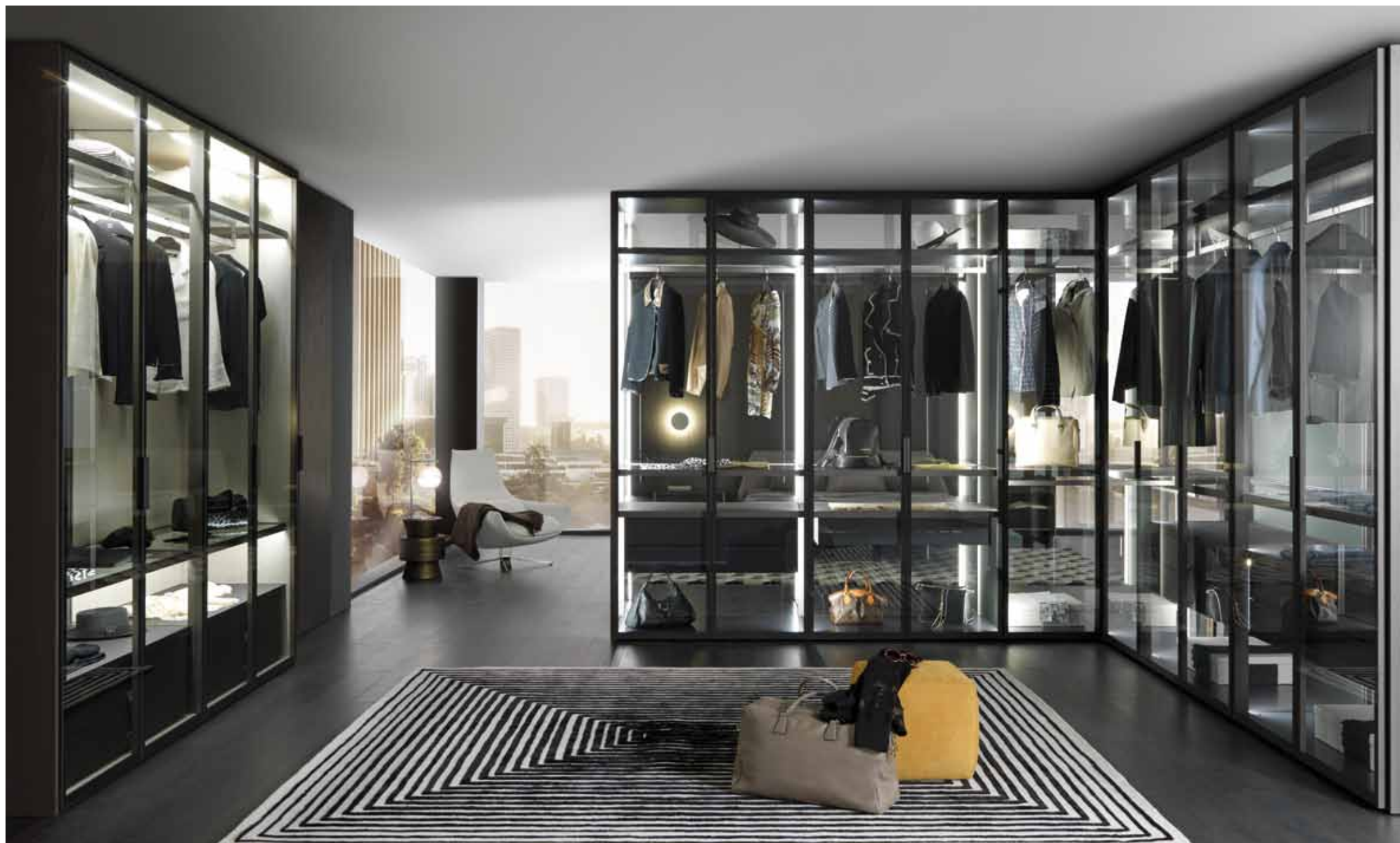

Armadio a destra: sistema **Palo Alto** con ante **Narcisse**, schienali e spalle terminali in vetro trasparente, telai e profili in finitura Canna di Fucile, cassettiere sospese con top in ecopelle, ripiani in vetro montati su telaio in alluminio finitura Canna di Fucile. Sulla sinistra: sistema **Palo Alto** con accostamento di due diverse profondità, abbinamento di ante **Narcisse** in vetro trasparente e ante **Milano** in Olmo Grey.

Right wardrobe: **Palo Alto** system with **Narcisse** doors, back panels and end panels in transparent glass, side profiles and frame in aluminum Gun Metal finish, suspended chest of drawers with top in ecoleather, glass shelves with aluminum frame in Gun Metal finish. Wardrobe on the left: **Palo Alto** system with **Narcisse** and **Milano** doors in Elm Grey.





INTERIOR INSPIRATION 02

SONO I DETTAGLI INECCEPIBILI A FARSI PORTAVOCE DI UNA FILOSOFIA D'ARREDO CHE CONIUGA LAVORAZIONE ARTIGIANALE E INNOVATIVE TECNOLOGIE PRODUTTIVE. I TRADIZIONALI CODICI DELLA CASA SI AMPLIANO, ACCOGLIENDO AL LORO INTERNO MOLTEPLICI COMBINAZIONI E DECLINANDOSI IN UNO SPETTRO INFINITO DI POSSIBILITÀ. NE SCATURISCONO ATMOSFERE INEDITE, LE PROPRIE, IN CUI PRENDE VITA IL MICRO COSMO DEL VIVERE QUOTIDIANO CUCITO SU MISURA, COME IL MIGLIOR ABITO DELL'ALTA SARTORIA, PER RISPONDERE AI DESIDERI DEI SUOI ABITANTI.

THESE FLAWLESS DETAILS REPRESENT A FURNISHING PHILOSOPHY THAT COMBINES CRAFTSMANSHIP AND INNOVATIVE PRODUCTION TECHNOLOGIES. TRADITIONAL DOMESTIC RULES ARE EXPANDED TO INCLUDE MULTIPLE COMBINATIONS AND EXPLORED IN AN INFINITE SPECTRUM OF POSSIBILITIES. THE RESULT IS NEW ATMOSPHERES THAT PRODUCE A MICRO COSMOS OF EVERYDAY LIFE THAT IS TAILOR-MADE, LIKE THE BEST HAUTE COUTURE DRESS, TO SATISFY THE WISHES OF ITS INHABITANTS.





In queste pagine e in quella precedente: sistema giorno **Over** in essenza Olmo Grey con inserti su schienali, spalle e cassetti in vetro verniciato, ripiani in estruso di alluminio rivestiti in pelle, inserimento luci LED sotto ripiano con innovativo sistema illuminotecnico integrato per boiserie orizzontale, anta "Bar" in finitura essenza Olmo Grey. Madie **Milvian** con struttura e cassetti in essenza finitura Rovere Nero, spalle in alluminio verniciato Canna di Fucile, top in marmo. Poltrona **Violetta** con base girevole in metallo, rivestimento in cuoio e tessuto.

On these and previous: **Over** day system with structure veneer Elm Grey finish with varnished glass inserts on back panels, side panels and drawers, extruded aluminum shelves covered in leather, the horizontal electrified woodwork creates an innovative, integrated lighting system, "Bar" flap down door in Oak Grey veneer finish. **Milvian** sideboards with structure and drawers in Oak Black. Shaped sides in aluminum Gun Metal varnished, marble Top. **Violetta** armchair with metal swivelling base, covered in fabric and thick-leather.



Dettaglio delle spalle del sistema **Over** con inserto in vetro verniciato, ripiano in estruso di Alluminio rivestito in pelle.



Detail of the **Over** system sides with inserts in varnished glass, extruded aluminum shelf covered in leather.

Dettaglio dei cassetti rivestiti in vetro laccato lucido.



Drawers details covered in varnished glass.



In queste pagine e in quelle successive: composizione **Tao** con contenitori in finitura laccato lucido; mensola top sp. 80 mm e boiserie in essenza Rovere Nero; mensole in alluminio anodizzato con illuminazione LED Zaffiro; sistema contenitori **Maggie** composto da bussolotti, teche e vani a giorno in legno o vetro con cassettini svuotatasche in cuoio; contenitore sospeso rivestito in pelle scamosciata con cuciture a vista e top in marmo. Divano **Argo** con rivestimento in tessuto ed elementi libreria in essenza Olmo Grey. Tavolini **Kessler** con base in metallo canna di fucile e piano in vetro trasparente Fumé. Pouf **Stone** imbottito e rivestito in pelle stampata. Poltroncina **Violetta** con base girevole in metallo e rivestimento bicolore.

On these and next pages: **Tao** composition with containers in glossy lacquered finishing, shelf counter 80 mm thick and boiserie in Black Oak, shelves in anodised aluminum with Led Zaffiro lighting, **Maggie** system consisting of die boxes, display cases and wood or glass compartments, with small "pocket emptier" drawers in thick-leather; suspended container covered in suede with visible stitching and marble top. **Argo** sofa fabric cover and bookcase elements in Elm Grey wood finishing. **Kessler** side tables with Gun Metal base and Fumé transparent glass top. Upholstered **Stone** pouf covered in printed leather. **Violetta** armchair with metal rotating base and two-tone covering.





A sinistra: dettaglio composizione **Tao** con boiserie e mensola top sp. 80 mm in essenza Rovere Nero. Sistema contenitori **Maggie** composto da bussoiotti, teche e vani a giorno in legno o vetro, con cassettoni svuotatasche in cuoio. Pouf **Stone** imbottito e rivestito in pelle stampata.



On left: detail of **Tao** composition with boiserie and shelf top 80 mm thick in Black Oak. **Maggie** system consisting of die boxes, display cases and wood or glass compartments, with small "pocket emptier" drawers in thick-leather. Upholstered **Stone** Pouf covered in printed leather.





In queste pagine: composizione **Tao** con boiserie e mensola top sp. 80 mm in essenza Rovere Nero, sistema contenitori **Maggie** composto da bussolotti, teche e vani a giorno in legno o vetro, con cassettoni svuotatasche in cuoio. Tavolo **Gaudi** con base in massello Rovere Nero e piano in marmo Sahara Noir. Sedie **Bertha** con struttura in essenza Rovere Nero e sedile rivestito in tessuto.

On these pages: **Tao** composition with boiserie and shelf top 80 mm thick in Black Oak. **Maggie** system container consisting of die boxes, display cases and wood or glass compartments, with small "pocket emptier" drawers in thick-leather. **Gaudi** table with base in solid Black Oak and top in Sahara Noir marble. **Bertha** chairs with structure in Black Oak and fabric clad seat.



Tavolo **Gaudi** con base in massello Rovere Nero e piano in marmo Sahara Noir. Sedie **Bertha** con struttura in essenza Rovere Nero e sedile rivestito in tessuto.



Gaudi table with base in solid Black Oak and top in Sahara Noir marble. **Bertha** chairs with structure in Black wood and fabric clad seat.







A sinistra: particolare del divano **Argo** con rivestimento in tessuto. Sotto: tavolino cilindrico **Moai** in massello laccato lucido.



On left: detail of the sofa **Argo** with fabric cover. Above: **Moai** cilindric small table in glossy lacquered solid wood.

In queste pagine: letto **Margareth** con piedini in legno massello in finitura Rovere Nero e rivestimento in pelle con bordino come struttura. Tavolino **Gramercy** con struttura in massello Rovere Nero e piani in marmo Calacatta Oro e laccato lucido (anche sottopiano laccato lucido). Poltrona **Florentia** con base in massello curvato finitura Rovere Nero e rivestimento bicolore in pelle liscia e pelle lavorata. Libreria **WL2** in lamiera grezza di acciaio in finitura grigio metallizzato ed elemento di tensione in cavetto di acciaio.

In these pages: **Margareth** bed with base frame in solid wood, finish Oak Black and leather cover with stitching in same color as base frame. **Gramercy** small table with solid wood base in Oak Black finish and tops in Calacatta Oro and in glossy lacquered version (undersurface also in glossy lacquered). **Florentia** armchair with solid wood base in Oak Black and two-tones cover in leather. **WL2** tensobookcase in sheet-steel, metallic grey finish, with steel cable as straightening element.



Nelle pagine precedenti: letto **Margareth** con struttura in massello in finitura Rovere Nero e rivestimento in pelle con bordino in finitura struttura. Comodino **Lindo** con base verniciata Canna di Fucile, struttura in Rovere Nero e piano in marmo Calacatta Oro. In queste pagine: tavolino **Gramercy** con struttura in massello finitura Rovere Nero e piano in marmo Calacatta Oro.



In the previous pages: **Margareth** bed with base frame in solid wood, finish Oak Black and leather cover with stitching in same color as base frame. **Lindo** bedside table with Gun Metal base, structure in Oak Black and Calacatta Oro marble top. On these pages: **Gramercy** small table with solid wood base in Oak Black finish and Calacatta Oro marble top.







A sinistra: vista retroletto **Margareth** rivestito in pelle con bordino a contrasto, giroletto in massello Rovere Nero. Sotto: dettaglio comodino **Lindo** con top in marmo Calacatta Oro.



On left: view of **Margareth** bed, headboard rear side in leather cover with stitching in contrast, bedframe in solid wood finish Oak Black. Above: detail bedside table **Lindo** with Calacatta Oro marble top.

INTERIOR INSPIRATION 03

SOLUZIONI D'ARREDO NATE DA UNA TRADIZIONE ARTIGIANALE CENTENARIA E FAUTRICI DI UN INSTANCABILE E LABORIOSO CONTRIBUTO AI VALORI DEL MADE IN ITALY. UN PATRIMONIO COSTRUITO NEL TEMPO E INTRAMONTABILE, IN CUI L'APPORTO DI ALCUNE DELLE PIÙ IMPORTANTI FIRME DEL MONDO DEL DESIGN HA DATO VITA A SISTEMI MODULARI PER LA ZONA GIORNO E NOTTE, COLLEZIONI DI LETTI, LIBRERIE, SEDUTE, TAVOLI E COMPLEMENTI. CLASSICI SENZA ETÀ E RISULTATI DI MONITORAGGI ATTENTI AGLI SCENARI DELLA CONTEMPORANEITÀ E AI LORO CAMBIAMENTI.

FURNISHING SOLUTIONS THAT ARE THE RESULT OF A CENTURIES-OLD ARTISAN TRADITION OF CRAFTSMANSHIP, TIRELESSLY AND INDUSTRIOUSLY CONTRIBUTING TO THE VALUES OF MADE IN ITALY. TIMELESS HERITAGE THAT HAS BEEN ESTABLISHED OVER MANY YEARS, IN WHICH THE CONTRIBUTION OF SOME OF THE MOST IMPORTANT FIGURES IN THE DESIGN WORLD HAS LED TO MODULAR SYSTEMS FOR THE LIVING AND SLEEPING AREAS, BED COLLECTIONS, BOOKCASES, CHAIRS, TABLES AND ACCESSORIES. AGELESS CLASSICS THAT ARE THE RESULT OF CAREFUL MONITORING OF CONTEMPORARY SCENARIOS AND THEIR CHANGES.







Nelle pagine precedenti: composizione **Crossing**, struttura laccato opaco Grigio Lava, schienali in essenza Rovere Cenere, ante in essenza Rovere Fumè, raster sp.14 mm laccato opaco Grigio Lava, elemento integrato **Palo Alto** con ante **Teka** in vetro trasparente Fumè, fianchi telaio centrali con vetro trasparente Fumè e luce LED Zaffiro integrata. In queste pagine: poltrona **Ermes Vesta** con rivestimento in tessuto. Tavolino rotondo **Gramercy** con struttura in massello finitura Olmo Grey, piano in Essenza Olmo Grey e sottopiano laccato lucido.



On the previous pages: **Crossing** composition, structure matt lacquer Grigio Lava, back panels in wood veneer Oak Cenere, flap door in wood veneer Oak Fumè, raster 14 mm thickness matt lacquer Grigio Lava with incorporated **Palo Alto** unit with **Teka** in Fumè transparent glass doors, central uprights with transparent glass Fumè and LED lights. On these pages: **Ermes Vesta** armchair cover in fabric. **Gramercy** round small table base in solid oakwood Elm Grey, top in wood Elm Grey and undersurface glossy lacquer.

In queste pagine: composizione **Crossing**, struttura laccato opaco Grigio Lava, schienali in essenza Rovere Cenere, ante in essenza Rovere Fumé, raster sp.14 mm laccato opaco Grigio Lava, elemento integrato **Palo Alto** con ante **Teka** in vetro trasparente Fumé, fianchi telaio centrali con vetro trasparente Fumé e luce LED Zaffiro integrata. Tavolini quadrati **Gramercy** con struttura in massello finitura Rovere Nero, piano in marmo Marquinia ed essenza Rovere Cenere, sottopiano laccato lucido. Divano **Madison** con rivestimento in tessuto e piedi in metallo nichel satinato. Poltrona **Ermes** con rivestimento in tessuto e base girevole in acciaio.

On these pages and on the previous ones: **Crossing** composition, structure mat lacquer grigio lava, back panels in wood veneer Oak Cenere, flap door in wood veneer Oak fumé, raster 14 mm thickness mat lacquer grigio lava, with **Palo Alto** unit with **Teka** in Fumé transparent glass doors, central uprights with transparent glass Fumé and LED lights. **Gramercy** square small tables base in solid wood Oak Black and top in Marquinia marble and wood veneer Oak Cenere, undersurface glossy lacquer. **Madison** sofa with cover and feet in satinated metal. **Ermes** armchair with cover in fabric and swivel base in satinated stainless steel.



In questa pagina: dettaglio dell'anta "Bar" del sistema **Crossing**. A destra: dettaglio dell'elemento integrato **Palo Alto** con ante **Teka** in vetro trasparente Fumé, fianchi telaio centrali con vetro trasparente Fumé e luce LED Zaffiro integrata, ripiani in vetro sp. 12 mm, cassetteria interna laccata opaca e schienali in essenza Rovere Fumé.



In this page: detail of "Bar" flap down door on **Crossing** system. On the right: detail of **Palo Alto** unit incorporated in **Crossing** system with **Teka** in Fumé transparent glass doors, central uprights with transparent glass Fumé and LED lights, glass shelves 12 mm thickness, drawers unit mat lacquer and back panels in wood veneer Oak Fumé.



In queste pagine: composizione **Crossing**, finitura struttura laccato opaco Grigio Lava, schienali in essenza Rovere Cenere, ante in essenza Rovere Fumé, raster sp.14 mm laccato opaco Grigio Lava e luci LED Zaffiro integrate. Tavolini quadrati **Gramercy** con struttura in massello finitura Rovere Nero, piano in marmo Marquinia ed essenza Rovere Cenere, sottopiano laccato lucido. Divano **Madison** con rivestimento in tessuto e piedi in metallo nichel satinato.

On these pages: **Crossing** composition, structure mat lacquer Grigio Lava, back panels in wood veneer Oak Cenere, flap door in wood veneer Oak Fumé, raster 14 mm thickness mat lacquer Grigio Lava and LED lights. **Gramercy** square small tables base in solid wood Oak Back and top in Marquinia marble and wood veneer Oak Cenere, undersurface glossy lacquer. **Madison** sofa with cover in fabric and feet in satinated metal.





A sinistra: tavolino **Gramercy** con struttura in massello Rovere Nero e piano in marmo Marquinia. Divano **Madison** con rivestito in tessuto. Composizione **Crossing** con ante "Bar" ribalta in Rovere Fumé. Sotto: tavolino **Gramercy**, dettaglio del top in marmo Marquinia ad angoli stondati.



To the side: **Gramercy** table with base in solid wood Oak Black and top in Marquinia marble. **Madison** sofa with fabric cover. **Crossing** composition with flap down "Bar" door in Oak Fumé. Above: small table **Gramercy**, detail of Marquinia marble top with rounded edges.

In queste pagine: divano **Madison** con rivestimento in tessuto e piedi in metallo nichel satinato. Tavolini **Kessler** con base in alluminio finitura Canna di Fucile e piano in marmo Calacatta Oro e vetro trasparente Fumé. Tavolini **Gramercy** con base in massello finitura Rovere Nero e piano in vetro trasparente Fumé e marmo Marquinia. Su sfondo composizione **Crossing** con elementi libreria laccato opaco, schienale in essenza Rovere Cenere, elemento integrato **Palo Alto** con ante **Teka** in vetro trasparente Fumé, schienali in essenza Rovere Cenere, fianchi telaio centrali con vetro trasparente Fumé e luce LED Zaffiro integrata.

On these pages: **Madison** sofa with fabric cover and brushed nickel metal feet. **Kessler** side tables with Gun Metal aluminium base and top in Calacatta Oro marble and Fumé transparent glass. **Gramercy** tables with base in solid wood Oak Black and top in transparent glass Fumé and Marquinia marble. In the background: **Crossing** composition with bookcase elements matt lacquered, back in Oak Cenere wood, **Palo Alto** unit with **Teka** in Fumé transparent glass doors, Oak Cenere wood backs, central uprights with transparent glass Fumé and LED lights.



Sotto: particolare del tavolino **Kessler** con base in metallo canna di fucile e piano in marmo Emperador.
A destra: composizione **Crossing**, divano **Madison** rivestito in tessuto, tavolini **Kessler** con piano in vetro trasparente Fumé e marmo Calacatta Oro.



Above: detail of **Kessler** small table with metal Gun Metal varnished and Emperador marble top. On right: **Crossing** composition, **Madison** sofa fabric covered, **Kessler** small table with transparent glass Fumé and Calacatta Oro marble top.







In queste pagine: dettaglio della testata letto **Sumo** bicolor. A sinistra: tavolino **Gramercy** con struttura in massello finitura Rovere Fumé piano e sottopiano laccato lucido. Sistema ante **Layer** a porte scorrevoli in vetro riflettente Fumé, ante **Layer** e cabina armadio **Palo Alto**.



In this pages: detail of the two-tone **Sumo** headboard. Left: **Gramercy** side table with solid wood structure, Oak Fumé finish, top and undersurface in glossy lacquered finish. **Layer** system doors with Fumé reflective glass, **Layer** doors and **Palo Alto** walk-in closet.

In queste pagine e in quelle precedenti: cabina armadio **Palo Alto**, innovativa soluzione ad angolo interamente in vetro. Ante, spalle centrali e terminali in vetro trasparente, schienali in vetro satinato, finitura fianchi telai e profili in metallo Canna di Fucile, cassettiere sospese con piano rivestito in ecopelle, ripiani in vetro con telaio in alluminio Canna di Fucile. Anta **Narcisse** in vetro trasparente. Sulla sinistra armadio "Bow window" con diversa profondità rispetto alla scarpiera, interno in nobilitato Shantung di seta con luci LED integrate nei montanti e nel sottopiano.

On these pages and on the previous ones: **Palo Alto** walk-in closet, innovative, completely in glass corner configuration. Doors, side panels and end panels in transparent glass, back panels in satinated glass, side profiles and frame in Gun Metal finish, suspended drawers with ecoleather covered top, glass shelves with aluminum frame in Gun Metal finish. **Narcisse** door in transparent glass. On the left "Bow window" wardrobe with different depth in respect to the rack shoes element, internal structure in Shantung di seta melamine; LED lights built into the uprights and under shelves.







Nelle pagine precedenti e a destra: cabina armadio **Palo Alto** in nobilitato Olmo Tranchè, fianco telaio in finitura canna di fucile, cassettiera sospesa, luce LED Zaffiro verticale, anta **Narcisse** in vetro trasparente con profili canna di fucile. Consolle **Virgo** laccata lucido. **Pouf** con rivestimento in velluto. In questa pagina: dettaglio dell'apertura dell'anta **Narcisse** dotata di due cerniere dedicate e ammortizzate, incassate nel basamento e nel coperchio.



On the preceding pages and right: **Palo Alto** walk-in closet in Elm Tranchè melamine, frame in gunmetal finish, suspended chest of drawers, vertical Zaffiro LED lights, **Narcisse** door in transparent glass with gun metal profiles. **Virgo** console in glossy lacquered finish. **Pouf** with velvet cover. Above: detail of the **Narcisse** door opening, fitted with specifically designed soft-closing hinges integrated in the base and the cover.

INTERIOR INSPIRATION 04

UNA LINEARE FUNZIONALITÀ E UNA PULIZIA ESTETICA NATE DALL'INCONTRO TRA LA PIÙ CLASSICA DELLE GEOMETRIE E IL PIÙ RINOMATO DESIGN ITALIANO. QUESTE LE CARATTERISTICHE – E LE PAROLE CHIAVE – CHE VANNO A DEFINIRE UN UNIVERSO ABITATIVO RAFFINATO ED ELEGANTE IN CUI MATERIALI PREZIOSI SI ACCOSTANO ALLE NOBILI VENATURE DEL LEGNO, DANDO RISALTO AI PREGEVOLI CONTRASTI MATERICI. CIFRE PROGETTUALI INEQUIVOCABILI DALL'ALLURE CONTEMPORANEA.

LINEAR FUNCTIONALITY AND A CLEAN AESTHETIC RESULTING FROM THE COMBINATION OF THE MOST CLASSIC GEOMETRIES AND THE MOST RENOWNED ITALIAN DESIGN. THESE ARE THE CHARACTERISTICS – AND THE KEY WORDS – THAT DEFINE A REFINED AND ELEGANT LIVING UNIVERSE IN WHICH PRECIOUS MATERIALS ARE COMBINED WITH THE NOBLE GRAIN OF WOOD, EMPHASIZING PRECIOUS MATERIAL CONTRASTS. UNMISTAKABLE DESIGN WITH A CONTEMPORARY ALLURE.





Nelle pagine precedenti e in queste: composizione **Tao10** con contenitori in finitura Essenza Rovere Fumè e laccato opaco, elementi libreria **Crossing** laccati opachi, Boiserie in finitura Tecno-Marble e laccato lucido. Tavolino **Kessler** con base in alluminio satinato e piano in Essenza Rovere Fumè. Divano **Argo** con rivestimento in tessuto sfoderabile.

On the preceding pages and on these pages: **Tao10** composition with containers in veneered Oak Fumè and matt lacquer finishes, **Crossing** bookshelf elements in matt lacquered finish, paneling in Techno-Marble and glossy lacquered finishes. **Kessler** coffee table with base in satinated aluminum and top in veneered Oak Fumè. **Argo** sofa with removable fabric cover.



In queste pagine: composizione **Tao10** con contenitori in finitura essenza Rovere Fumè e laccato opaco, elementi libreria **Crossing** laccati opachi, Boiserie in finitura Tecno-Marble e laccato lucido. Tavolino **Kessler** con base in alluminio satinato e piano in essenza Rovere Fumè. Divano **Argo** con rivestimento in tessuto sfoderabile.



On this pages: **Tao10** composition with containers in veneered Oak Fumè and matt lacquer finishes, **Crossing** bookshelf elements in matt lacquered finish, paneling in Techno-Marble and glossy lacquered finishes. **Kessler** coffee table with base in satinated aluminum and top in veneered Oak Fumè. **Argo** sofa with removable fabric cover.





In queste pagine e nelle precedenti: divano ad angolo **Phoenix** con rivestimento in tessuto, elemento chaise-longue, pouf con elegante cucitura rivestito in pelle Nabuk. Cuscini in velluto e pelle Nabuk. Tavolino **Janus** con base in metallo verniciato nero con particolari in nichelato oro e top in vetro riflettente Fumé. Tavolino **Sirius** nichelato oro con top in marmo Calacatta oro. Tavolino **Moai** in massello di legno laccato lucido.

On these pages and on the previous ones: **Phoenix** sofa corner configuration, chaise-longue element and pouf with elegant stitchings covered in Nabuk leather. Cushions in velour and Nabuk leather. Table **Janus** with metal base Black varnished in gold nickel and Fumé reflective glass top. Small table **Sirius** gold nickel finish with marble top Calacatta oro. **Moai** small table in solid wood glossy lacquered.





In queste pagine: armadio **I-Box** con anta **Milano** apertura battente, finitura in essenza Rovere Fumè vena verticale con maniglia **Acanto**. Nelle pagine successive: Poltrona **Ermes** con base in massello finitura Rovere Fumè e rivestimento in velluto. Tavolino **Gramercy** con base in massello finitura Rovere Fumè e piano laccato lucido (sottopiano laccato lucido).



On these pages: **I-Box** wardrobe with **Milano** hinged door, veneered Oak Fumè finish with vertical grain and **Acanto** handle. On the following pages: **Ermes** armchair with base in Oak Fumè finished solid wood and velvet cover. **Gramercy** side table with base in Oak Fumè finished solid wood with top and undersurface in glossy lacquered finish.



In queste pagine: Letto **Cosy** con contenitore e rivestimento in tessuto con inserti laterali in pelle scamosciata. Tavolino **Ring** con base in metallo Canna di Fucile e piano in marmo Marquinia. **Pouf** con rivestimento in tessuto, **mensoline** in finitura Canna di Fucile sp. 12 mm con illuminazione a LED integrata. **Mensolone** scrivania sp. 80 mm in essenza Olmo Grey.

On these pages: **Cosy** storage bed, fabric cover with lateral suede inserts. **Ring** small table with Gun Metal base and Marquinia marble top. **Pouf** with fabric cover, shelves th.12 mm in Gun Metal finish with incorporated led lights. Desktop th.80 mm in Elm Grey veneer.



In queste pagine: l'originale testata gioca con le linee oblique e il dinamismo delle geometrie. Insetti a contrasto in pelle scamosciata la incorniciano lateralmente animando cromaticamente le forme morbide della struttura. Tavolino **Ring** con base in metallo Canna di Fucile e piano in marmo Marquinia. Mensolone scrivania sp. 80 mm in essenza Olmo Grey.



On these pages: the original headboard plays with oblique lines and dynamic geometries. Contrasting suede inserts frame the sides, animating the soft forms of the structure with colour. **Ring** small table with Gun Metal base and Marquinia marble top. Desktop th.80 mm in Elm Grey veneer.









Nelle pagine precedenti: cabina armadio **Palo Alto** in nobilitato Olmo Tranchè, fianco telaio in finitura Canna di Fucile, cassettera sospesa, luce LED Zaffiro verticale, anta **Narcisse** in vetro trasparente con profili Canna di Fucile. Sistema **Layer** a porte scorrevoli in vetro Grigio Fumè. Sotto: particolare della soluzione ad angolo. Destra: dettaglio luce LED Zaffiro incassata nel montante.



Previous pages: **Palo Alto** walk-in closet in Tranchè Elm melamine, frame in Gun Metal finish, suspended chest of drawers, vertical Zaffiro LED lights, **Narcisse** door in transparent glass with Gun Metal profile. **Layer** system sliding doors in Grey Fumè glass. Above: details of corner option. Right: details of Zaffiro LED lights built into the uprights.

In queste pagine: cabina armadio **Palo Alto** in nobilitato Olmo Tranchè, fianco telaio in finitura Canna di Fucile, cassetteria sospesa, luce LED Zaffiro verticale, anta **Narcisse** in vetro trasparente con profili Canna di Fucile. Sotto: particolare della soluzione ad angolo.



On this pages: **Palo Alto** walk-in closet in Tranchè Elm melamine, frame in Gun Metal finish, suspended chest of drawers, vertical Zaffiro LED lights, **Narcisse** door in transparent glass with Gun Metal profile. Above: details of corner option.



DETTAGLI TECNICI_ TECHNICAL DETAILS

UN MATERIALE PREGIATO, CHE EVOCA TRADIZIONE E SUSCITA
EMOZIONI. UN VALORE AGGIUNTO CHE SOTTOLINEA LA
MANUALITÀ DELLA CONFEZIONE E NE ESALTA LA QUALITÀ E
L'ELEGANZA AL DI LÀ DEL TEMPO E DELLE MODE.

A PRECIOUS MATERIAL THAT IS REMINISCENT OF TRADITION
AND EVOKES EMOTIONS. AN ADDED VALUE THAT HIGHLIGHTS
A HANDCRAFTED CONSTRUCTION AND ENHANCES A TIMELESS
ELEGANCE THAT TRANSCENDS FASHION TRENDS.



SISTEMI GIORNO _ SYSTEMS

CROSSING design Mauro Lipparini

Crossing è un sistema componibile poliedrico, caratterizzato da pannelli che consentono di ottenere scaffalature sospese. Totalmente regolabile lungo i tre assi tridimensionali. Garantisce una portata max. di 400 kg. Il programma prevede una serie di moduli in varie tipologie e dimensioni, pensili a ribalta, ante a battente, scorrevoli e cassetti in diverse misure. Crossing è proposto in versione Fusion (con elementi in agglomerato a particelle di legno in nobilitato oppure laccato) o in versione Listellare (in listellare di pino impiallacciato o laminato). All'interno dei vani è collocato uno speciale sistema di illuminazione led. Finiture in laccato opaco, lucido colori, essenza, nobilitato.

Crossing is a versatile modular system of panels with which to create wall-mounted shelving. Totally adjustable along the three dimensional axes, it can support up to 400 kg. The program offers a series of modules of different types and sizes, hanging cabinets with flap, leaf or sliding doors, and drawers in a range of sizes. Crossing is available in the Fusion version (with parts in faced or lacquered wood particle board) or in the Listellare version (veneered or laminated poplar blockboard). The compartments contain a special LED lighting system. Finishes: matte lacquer, glossy colours, natural wood, veneer/facing.



Raster

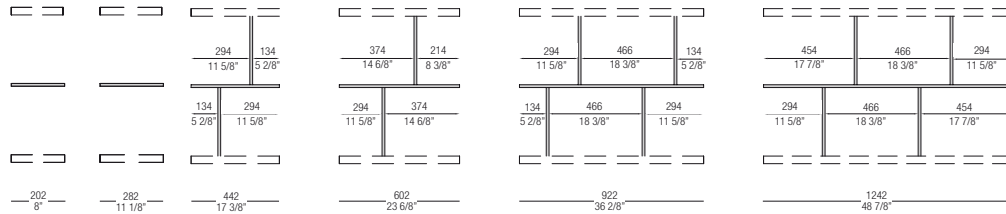

Larghezza
Width

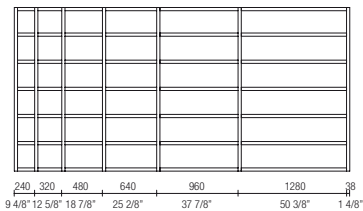

Spalle da inserimento / Sp.38mm
Insertions panels / Th. 1 1/4"

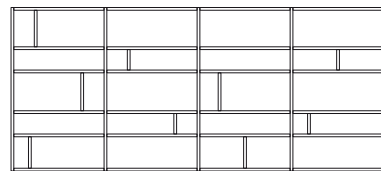

Altezza per moduli a terra
Heights for floor-based modules

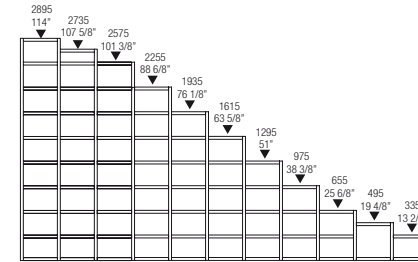

Altezza per moduli sopra su contenitori
Heights for overhanging modules on containers

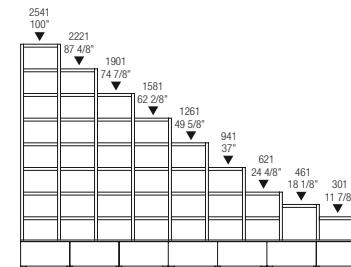

Profondità
Depth



Altezza per moduli pensili
Hights for hanging modules

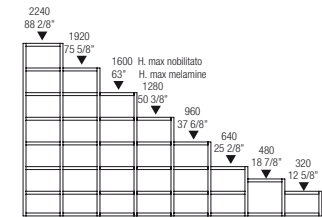

Altezza vani
Compartment height

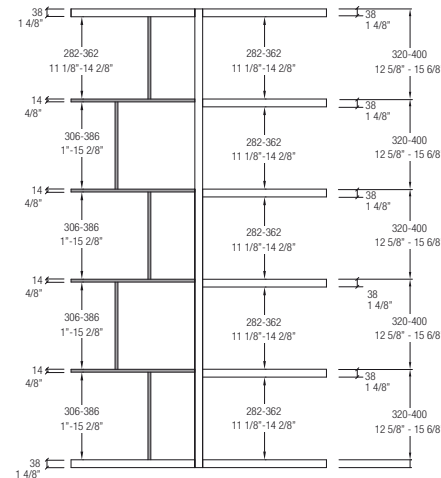

SISTEMI GIORNO _ SYSTEMS

URBAN design Iriam Bettera

Moduli libreria composti da ripiani orizzontali in 20 lunghezze, a passo 120mm., intervallati da scatole in metallo oppure da spalle ad inserimento, in 2 altezze. Per la portata dei ripiani, è obbligatorio ogni 840mm. disporre una colonna di scatole oppure scatole alternate a spalle inserimento. È possibile formare composizioni bifacciali oppure composizioni a parete che possono essere completate da contenitori a ribalta, con cassetti o modulo pannello TV. I ripiani della libreria sono forati per il posizionamento delle scatole metallo e per le spalle inserimento. Struttura nelle finiture in Laccato Opaco, Laccato Lucido, Nobilitato. Scatole in metallo verniciato nei colori di campionario.

Bookcase modules made of horizontal shelves in 20 lengths, with 120 mm pitch and interrupted by metal boxes or by insertion side panels, in 2 heights. For shelf capacity, a column of boxes or boxes alternated with insertion side panels must be inserted every 840mm. Free-standing compositions or wall compositions are available that can be completed with flap door, drawer or TV panel. The bookcase shelves have positioning holes for the metal boxes and insertion side panels. Structure in finish Matt Lacquer, Glossy Lacquer, Melamine. Metal with an epoxy enamel varnished in sample colors.

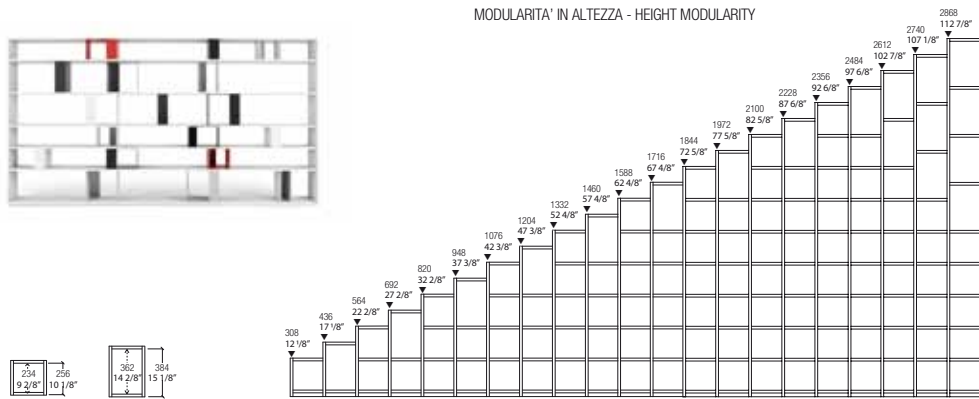

SCHEMA DI UTILIZZO CONTENITORI CON ANTE SCORREVOLI
DIAGRAM ON THE USE OF CONTAINERS WITH SLIDING DOORS

Contenitore con frontale "A FILO LIBRERIA"
Container with front panel "ALIGNED TO THE BOOKCASE"

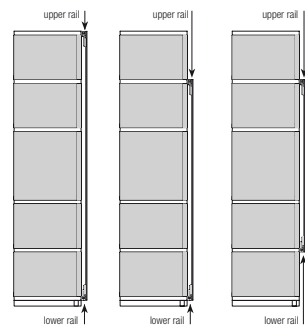

Contenitore avanzato per frontale "CON BATTUTA 3 LATI"
Container with external front "WITH REBATE ON 3 SIDES"

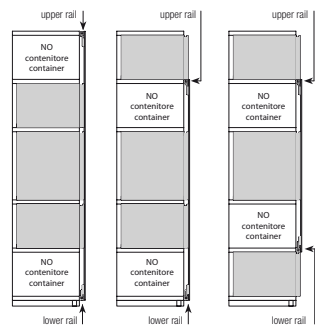

CONTENITORI FRONTALI
CONTAINERS WITH FRONT

A "FILO LIBRERIA":
anta ribalta down e cassetto
"FLUSH TO THE BOOKCASE":
flap down and drawer

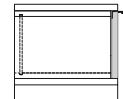

"BATTUTA 3 LATI":
anta ribalta down e cassetto (no push)
"WITH DOOR STOP ON 3 SIDES":
flap down and drawer (no push)

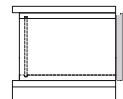

Griglia di sistema
Grid system

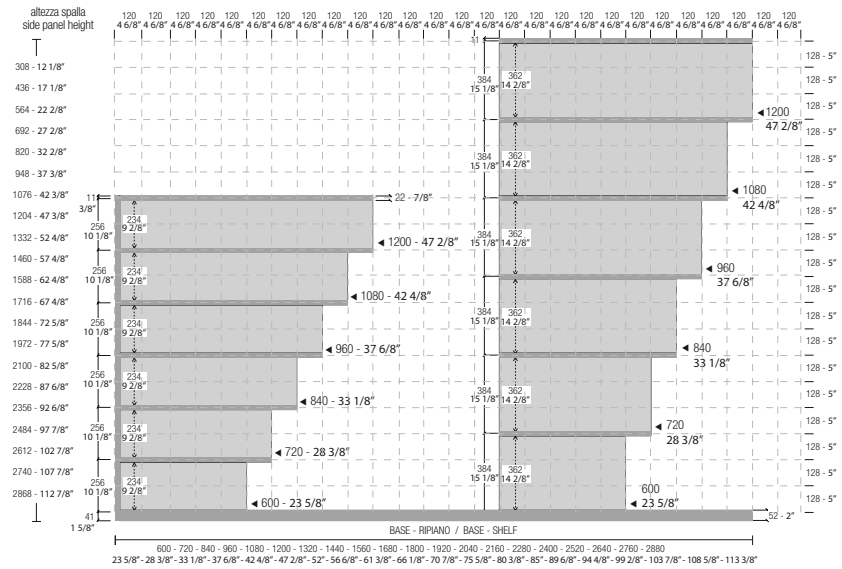

REGOLE DI COMPONIBILITA'
COMPOSITIONS RULES

Posizionamento scatole e spallette per l'inserimento in griglia
Examples of use, of how the boxes and risers must be "placed" to be entered in the grid

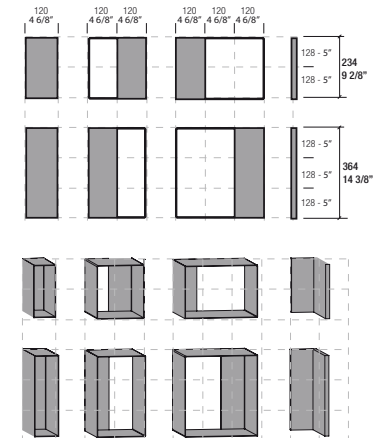
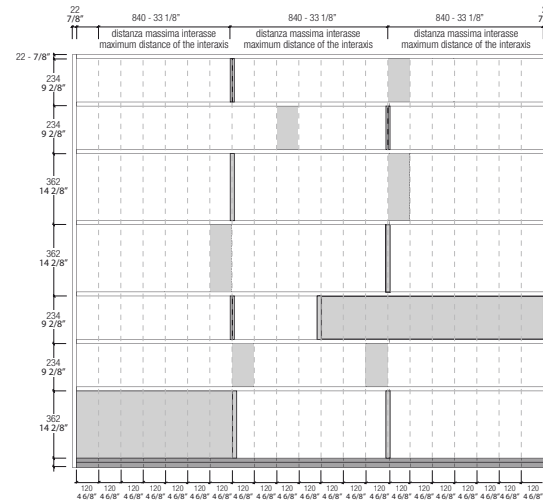

SISTEMI GIORNO _ SYSTEMS

TAO design Mauro Lipparini

Il sistema Tao può avere molteplici soluzioni ottenute componendo in modo differente gli elementi proposti in diverse dimensioni. Disponibile con laccatura ecologica o essenza. I suoi punti di forza sono: integrazione tridimensionale dei volumi, tecnologia innovativa integrata, massima flessibilità compositiva, solidità e portata, semplicità e invisibilità dei cablaggi, con o senza maniglia, ricchezza nei dettagli e nelle finiture, top in vetro. Il sistema è caratterizzato da un'intelaiatura in metallo per l'aggancio a muro, totalmente regolabile lungo i tre assi dimensionali con sistema anti-ribaltamento. Dotato di schienale asportabile per permettere l'accesso al vano dedicato allo stoccaggio di cavi e prese, ciò garantisce una portata max. di 150 Kg.

The Tao system has a wide range of solutions, which can be obtained by combining in different ways all the element. Available in various dimensions and finishes as eco-lacquer or veneer. His key factors are: three-dimensional integration of volumes, integrated innovative technology, highly flexible design creativity, weight capacity and stability, simplicity and invisible cables, no handle, richness in detail and finishes, glass top. Cabinet system with metal supporting frame, fully adjustable in width, height and depth. The frame has an anti-rollover system. The cabinet is fitted with a removable back panel for cables and wires management. Maximum loads capacity 150 kg.

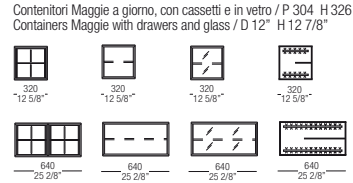
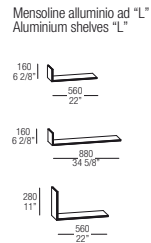
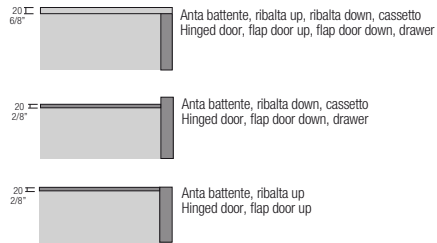

Mensole - panche a terra - piani top / sp. 80 P 300 - 436 - 516 - Shelves - floor bench - top / thick. 3 1/8" D 11 6/8"- 17 1/8"-20 3/8"

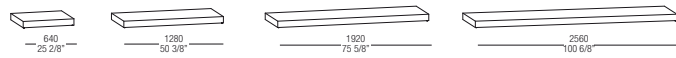

Mensole / sp. 38 P 304 - 380 Shelves / thick. 3 1/8" D 12"- 15"

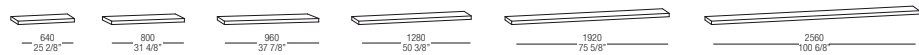

Mensole alluminio con e senza luci LED Zaffiro / P 213 - Aluminium shelves with or without LED Zaffiro / D 8 3/8

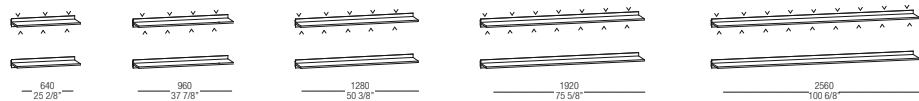

Contenitori base, standard, TV - P 384 - 490 / Contenitori pensili - P 384 Base containers, standard, TV - D 15 1/8"-19 2/8" / Hanging containers D 15 1/8"

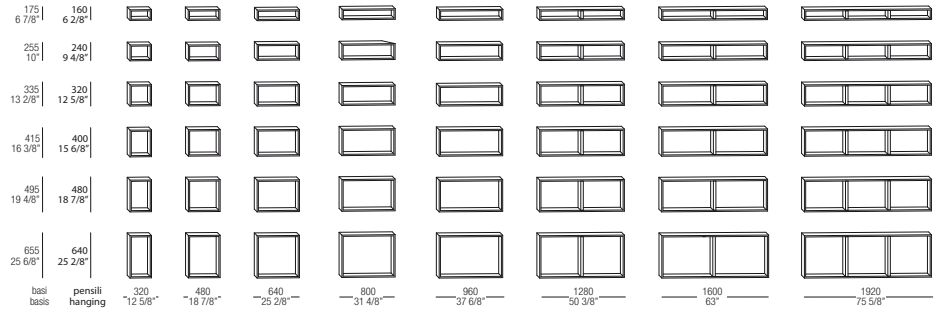

Contenitori pensili e TV - P 490 Hanging containers and TV - D 19 2/8"

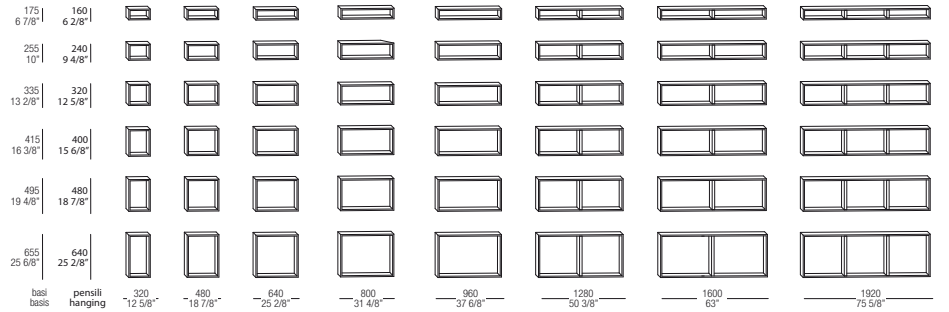

Contenitori base e standard - P 384 - 490 / Contenitori pensili P 384 Base containers e standard - D 15 1/8"-19 2/8" / Hanging containers D 15 1/8"

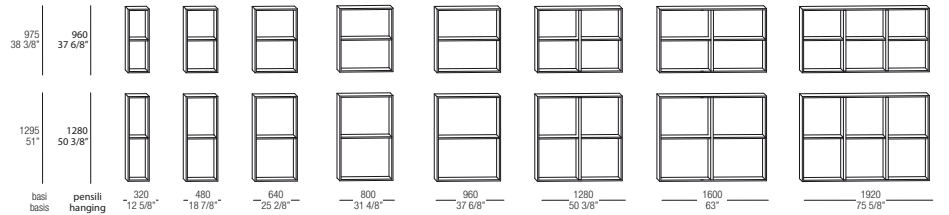

Contenitori base e standard - P 384 - 490 / Contenitori pensili P 384 Base containers e standard - D 15 1/8"-19 2/8" / Hanging containers D 15 1/8"

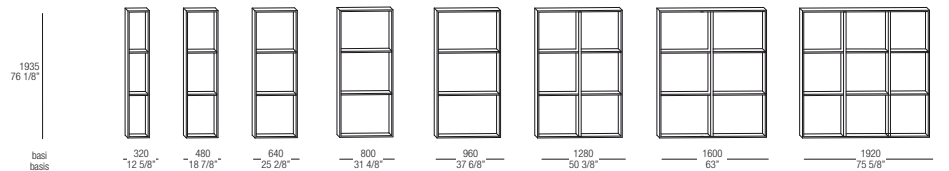

CABINE ARMADIO _ WALK-IN CLOSETS

PALO ALTO design Gianni Borgonovo

Palo Alto è un sistema innovativo per la zona notte, un nuovo progetto completo che permette di fruire lo stesso sistema sia come cabina armadio che come armadio con il completamento delle ante battenti, scorrevoli e coplanari della collezione MisuraEmme. Caratteristica peculiare di Palo Alto sono i fianchi disponibili in 5 altezze e 2 profondità, possono essere realizzati in legno, telaio con vetro o solo telaio per poter avere una visione totale e "trasparente". La regolazione dei piani in maniera continua permette un'ampia modularità dei vani consentendo la personalizzazione "su misura". Palo Alto è anche un sistema che offre funzionalità e ordine: vassoi, cassetti con frontale legno o cristallo, scarpiera estraibili, portapantaloni, porta camicie, portaorologi, portagioie, portascarpe, portapantaloni etc.

Palo Alto is an innovative system for the sleeping area, a new complete project in the MisuraEmme collection that allows the same system to be used as both a walk-in closet and as a wardrobe with hinged, sliding and coplanar doors. A special feature of Palo Alto is the sides available in 5 heights and 2 depths, which can be made of wood, of a frame with glass or just a frame for total, "transparent" vision. The continuous adjustment of the tops results in highly modular compartments, enabling "tailored" customization. The Palo Alto system also offers functionality and order: trays, drawers with wooden or glass fronts, removable shoe racks, trouser racks, shirt holders, watch cases, jewelry cases, shoe holders, trouser racks etc.



Struttura e attrezzatura /

Structure and inner equipment
nobilitato / melamine

Schienali / Back panels

specchio / mirror
vetro trasparente / transparent glass
vetro acidato / frosted glass
vetro riflettente / reflecting glass
nobilitato / melamine
laccato opaco / matt lacquer

Fianchi / Side panels

vetro trasparente / transparent glass
vetro acidato / frosted glass
vetro riflettente / reflecting glass
nobilitato / melamine
laccato opaco / matt lacquer

Interno cassetti / Internal drawers

nobilitato primofiore / melamine primofiore

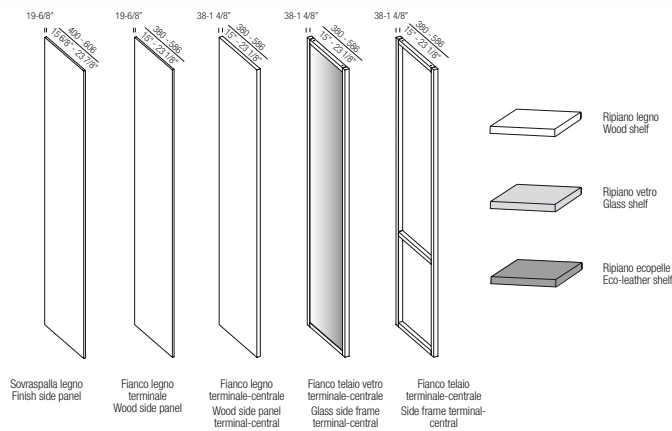

Modularità larghezza e altezza / Width and height modularity

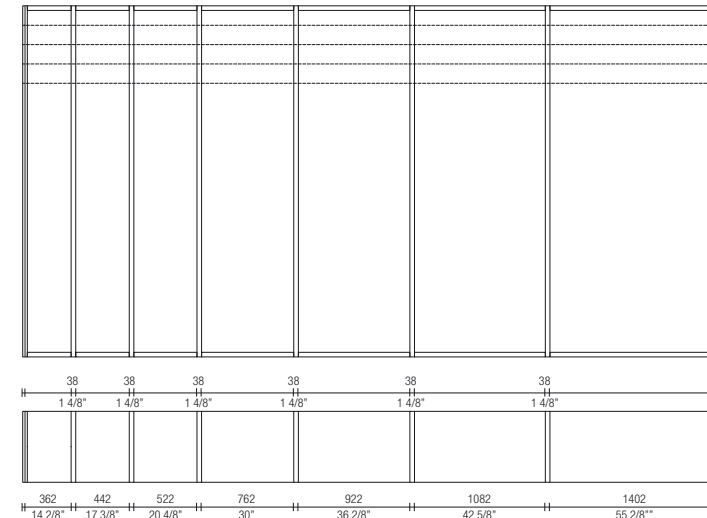

2902 _ 114 2/8"
2742 _ 108"
2582 _ 101 5/8"
2422 _ 95 3/8"
2262 _ 89"

La larghezza totale dell'armadio si ottiene sommando alle colonne le quote dei fianchi corrispondenti:
+ fianco terminale
+ fianco centrale (qualora ci siano più moduli)
+ fianco terminale

The total width of the cabinet is obtained by adding to the columns the dimensions of the corresponding sides:
+ terminal side
+ central flank (if there are more modules)
+ terminal side

380
15"
596
23 1/8"
spalle side panels
optional sovraspalla finish side panel

Ante battenti / Hinged doors

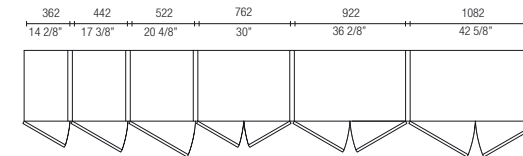

Ante scorrevoli / Sliding doors

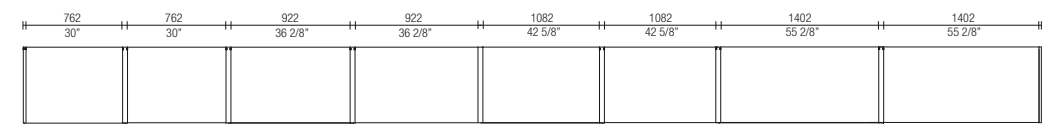

Ante coplanari / Coplanar doors

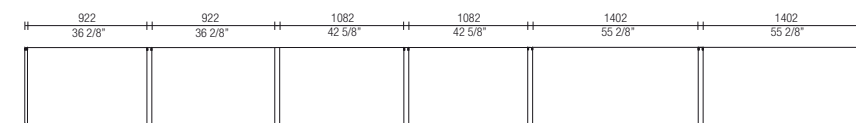

CABINE ARMADIO _ WALK-IN CLOSETS

MILLIMETRICA design Ennio Arosio

La modularità senza limiti è la carta vincente della cabina armadio Millimetrica. Uno spazio al servizio dei propri desideri, che risponde alle molteplici esigenze dettate dal lifestyle contemporaneo. Un sistema su misura dove comfort, precisione e organizzazione interpretano il vivere quotidiano. Dinamica e ultra leggera è invece la versione sospesa, che punta alla massima versatilità e libertà compositiva. Grazie al suo design minimale è la soluzione progettuale ideale per chi ama ritmo e flessibilità. **La cabina Millimetrica è possibile renderla sospesa agganciando a muro le spalle attraverso un sistema dedicato brevettato.** Il fianco Millimetrica ha spessore 38mm e profondità 304mm ed è disponibili in 5 altezze nella versione spalla a terra e 12 altezze nella versione sospesa. I ripiani sono disponibili in 2 profondità: 380mm e 495mm nella versione a terra e solo 380mm nella versione sospesa. Nella versione con fianco a terra sono possibili soluzioni con schienale legno, specchio oppure senza schienale. La versione sospesa è invece disponibile solo nella versione senza schienale.

Modularity without limits is the winning card of the Millimetrica walk-in closet. A space furnished according to one's desires, that answers to multiple needs deriving from a contemporary life style. A customizable system where comfort, precision and organisation interpret every day life. The suspended version instead is dynamic and ultra light and aims for maximum versatility and freedom in creating compositions. Thanks to its minimal and highly contemporary design, it is the ideal solution for those who love rhythm and flexibility. **The Millimetrica walk-in closet can be suspended by hooking the sides to the wall using a specially designed patented system.** The side of the Millimetrica walk-in closet is 1 4/8" thick and has a depth of 12" inch. in the floor based version, it is available in 5 heights, whereas in the suspended version it is available in 12 heights. The shelves are available in two depths, 15" inch and 19 4/8" inch in the floor based version, however are only available in 15" inch in the suspended version. In the floor based version, back panels are available in wood or mirror. There is also the possibility to have the floor based version without a back panel. The suspended version is only available without back panel.

Struttura e attrezzatura / Structure and inner equipment

nobilitato / melamine

Schienali / Back panels

senza schienale / without back panel

specchio / mirror

nobilitato / melamine



154

Larghezze e Altezze / Widths and Heights

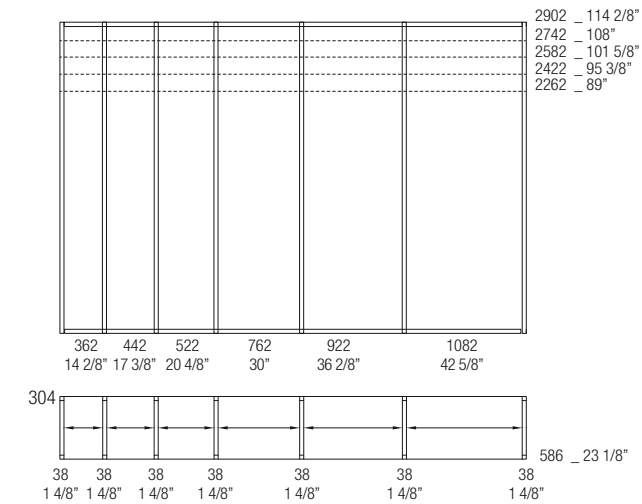

Tipologie fianchi / Side options

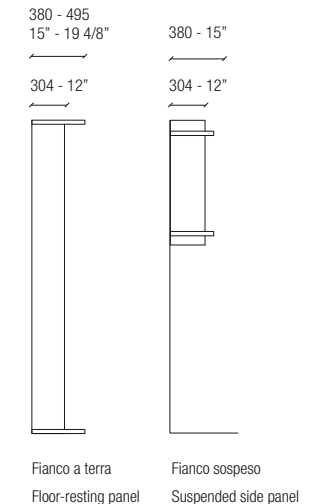

Per ottenere la larghezza totale della cabina, alla somma delle colonne aggiungere 38mm per ogni fianco, sia centrale che terminale.
To obtain the total width of the unit, inch 1 4/8" must added for each side panel, (central and end) to the sum of the modules.



155

CABINE ARMADIO _ WALK-IN CLOSETS

LAYER design CR&S MisuraEmme

Sistema di pannelli scorrevoli o fissi a parete per dividere due ambienti o per chiudere locali e cabine armadio. Permette di chiudere anche un vano porta. Il sistema è composto da binari guida in alluminio a una o due vie fissati a soffitto a vista o a incasso in un controsoffitto, su cui sono ancorati i pannelli fissi o scorrevoli. Le ante e i pannelli fissi consistono in un telaio in alluminio con vetro o specchio temperato disponibile in diverse finiture. Sopra i binari viene fissato un carter in finitura alluminio. Il sistema viene fornito completo di carrelli di scorrimento, fermi di chiusura e apertura, guida inferiore da fissare a pavimento (non ci sono binari a pavimento). Ogni ordine viene dimensionato secondo l'esigenza del cliente rispettando le limitazioni dei pesi e delle misure possibili. La misura massima in altezza ottenibile è di 3000mm compreso di binario e 1300mm in larghezza. L'apertura massima libera ottenibile è quella della misura di 2 ante. In corrispondenza dell'apertura dell'anta è applicata la maniglia sia all'esterno che all'interno in finitura come il telaio.

System of fixed or sliding panels to divide two home environments or to close a cabin wardrobe. Can also be used to close a doorway. The system consists of aluminium rails with one or two tracks fixed to the ceiling or incorporated in a suspended ceiling, where fixed or sliding panels are fastened. The sliding doors and fixed panels are made of an aluminium frame with tempered glass available in various finishes. An aluminium guard is used to hide the rails. The system is delivered complete with sliding mechanism, door stoppers, a lower sliding pin fixed to the floor (there are no rails on the floor). As this is a made to measure system, every order is developed according to the weight and possible dimensions. The max. height available is 3000 mm including the rails and 1300 mm in widths. Max. passage way is the size of two doors. Corresponding with the opening of the doors, a handle is placed on the inside and outside of the door, finish is same as door frame finish.



Dimensioni
- Altezza max. 3000 mm binario compreso

Fissaggio
- Parete / Wall
- Soffitto / Ceiling

Vetro
- Temperato sp. 6 mm / Tempered glass th. 6 mm
- Temperato sp. 3+3 mm per vetro verniciato

Dimensions
Max. height mm 3000 included rails

Fitting
- Wall
- Ceiling

Glass
- Tempered glass th. 6 mm
- Tempered glass th. 3+3 mm for varnished glass

1. L. 600÷900 mm
W 23 5/8"÷35 3/8" mm

2. L. 901÷1100 mm
W 35 4/8"÷43 2/8" mm

3. L. 1101÷1300 mm
W 43 3/8"÷51 1/8" mm

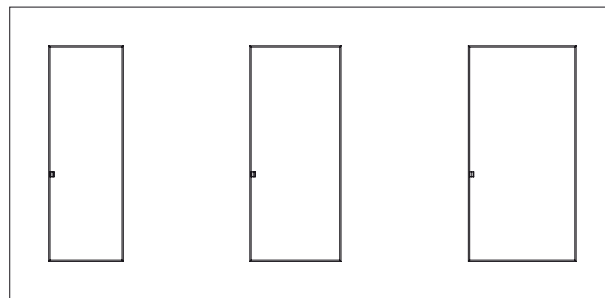

SOLUZIONI CON FISSAGGIO INTERNO VANO EXAMPLES WITH DOORS FITTED ON THE INSIDE OF A ROOM

Soluzioni a 2 vie / Section 2 way track

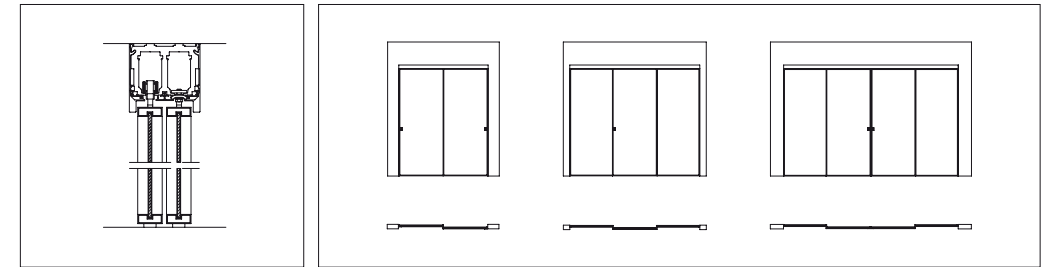

SOLUZIONI CON FISSAGGIO ESTERNO VANO EXAMPLES WITH DOORS FITTED ON THE OUTSIDE OF A ROOM

Soluzioni a 1 via / Section 1 way

Soluzioni a 2 vie / Section 2 way

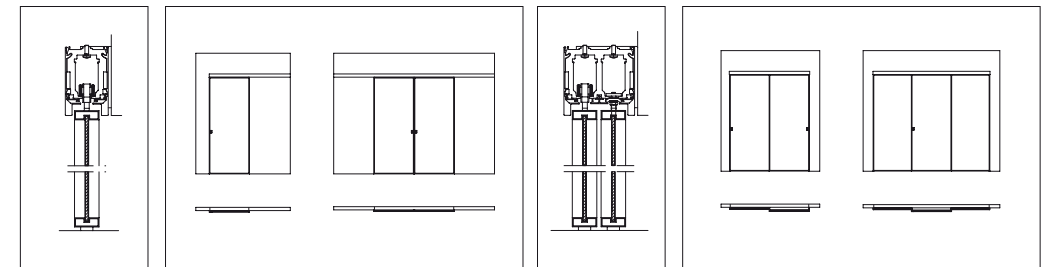

SOLUZIONI AD INCASSO SUL CONTROSOFFITTO (60 mm) EXAMPLES WITH DOORS INCORPORATED IN A SUSPENDED CEILING (2 3/8" inch)

Soluzioni a 2 vie / Section 2 way track

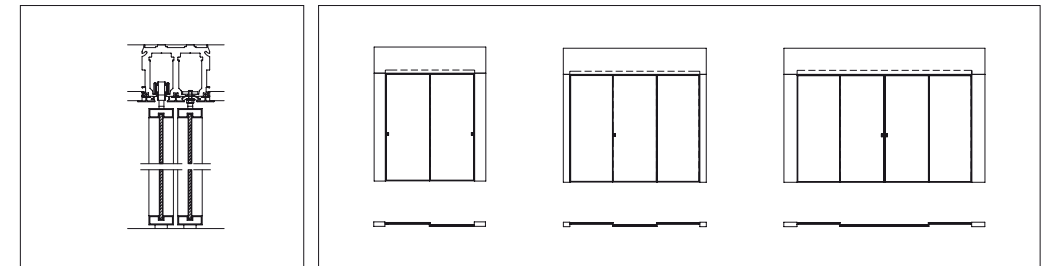

ARMADI _ WARDROBES

BRILLANTA design CR&S MisuraEmme

Un mood fortemente creativo contraddistingue l'armadio Brillanta. Anta in vetro o specchio con profilo bisellato nelle finiture anta Vetro Verniciato con profili Vetro Acidato Verniciato; Specchio con profili Specchio Acidato. Brillanta è disponibile con apertura battente, scorrevole o complanare. Vasta ed eterogenea scelta di maniglie.

A very creative mood distinguishes the wardrobe Brillanta. Glass doors or mirror with chamfered edges in the finish Varnished Glass with profile Frosted Varnished Glass; Mirror with profile Frosted Mirror. Brillanta as hinged, sliding or complanar doors. Wide and miscellaneous selection of handles.

Dimensioni ante mm / Doors dimensions inch

Battente - Hinged

L 396-476-556 H 2236-2396-2556 _ W 15 5/8"-18 6/8"-21 7/8" H 88"-94 3/8"-100 5/8"

Scorrevole - Sliding

L 805-965-1125-1445 H 2240-2400-2560 _ W 31 6/8"-38"-44 2/8"-56 7/8" H 88 2/8"-94 4/8"-100 6/8" - 56 7/8"

Complanare - Coplanar

L 956-1116-1436 H 2224-2384-2544 _ W 37 5/8"-43 7/8"-56 4/8"



ARMADI _ WARDROBES

MILANO design CR&S MisuraEmme

Eleganza e flessibilità sono le cifre distintive della nuova gamma Milano. Finiture anta in Laccato Lucido, Laccato Opaco, Essenza. Milano è disponibile con apertura battente, scorrevole o complanare. Vasta ed eterogenea scelta di maniglie. Una proposta straordinariamente personalizzabile grazie alla modularità delle ante che possono essere dimensionate in altezza e larghezza per consentire differenti progetti di arredamento: come il vano porta, il taglio su misura e soluzioni per locali mansardati.

Elegance and flexibility are the characteristics of the new Milano range. Doors in finish Matt Lacquer; Glossy Lacquer; veneer in Walnut, Oak Cenere, Oak Fumé, Oak Black. Milano as hinged, sliding or complanar doors and drawers. Wide and miscellaneous selection of handles. An extraordinarily customizable proposal thanks to the modularity of doors which can be tailored in height and width to allow for different furnishing designs: built-in door openings, bespoke arrangements and solutions for attics.

Dimensioni ante mm / Doors dimensions inch

Battente - Hinged

L 396-476-556 H 636-956-1276-1596-1916-2236-2396-2556-2716-2876

W 15 5/8"-18 6/8"-21 7/8" H 25"-37 5/8"-50 2/8"-62 7/8"-75 3/8"-88"-94 3/8"-100 5/8"-106 7/8"-113 2/8"

Scorrevole - Sliding

L 805-965-1125-1445 H 2240-2400-2560 _ W 31 6/8"-38"-44 2/8"-56 7/8" H 88 2/8"-94 4/8"-100 6/8" - 56 7/8"

Complanare - Coplanar L 956-1116-1436 H 2224-2384-2544 _ W 37 5/8"-43 7/8"-56 4/8"



ARMADI _ WARDROBES

LONDON design CR&S MisuraEmme

Particolari sofisticati per l'armadio London. Il gioco dei quadrati in rilievo e delineati da un'impuntura con la maniglia inserita nel rettangolo che divide i quadrati crea un gioco armonico. Anta in ecopelle lavorata o in pelle scamosciata con cuciture a vista. London è disponibile con apertura battente, scorrevole o complanare. Profilo e maniglia dedicata incassata in metallo verniciato Gesso, Satinato, Canna di Fucile.

London Wardrobe with sophisticated details. The squares in relief and outlined by topstitching, along with a handle inserted into the rectangle which divides the squares, create a harmonious design. Grey embossed eco-leather or suede leather, doors with stitching in view. London as hinged, sliding or complanar doors. Profile and specifically designed handle in metal finish varnished Gesso, Satined, Gun Metal.

Dimensioni ante mm / Doors dimensions inch

Battente - Hinged

L 396-476-556 H 2236-2396-2556 _ W 15 5/8"-18 6/8"-21 7/8" H 88"-94 3/8"-100 5/8"

Scorrevole - Sliding

L 805-965-1125-1445 H 2240-2400-2560 _ W 31 6/8"-38"-44 2/8"-56 7/8" H 88 2/8"-94 4/8"-100 6/8" - 56 7/8"

Complanare - Coplanar

L 956-1116-1436 H 2224-2384-2544 _ W 37 5/8"-43 7/8"-56 4/8"



ARMADI _ WARDROBES

NARCISSE design CR&S MisuraEmme

Narcisse, un connubio tra metallo e vetro. Anta in vetro verniciato, vetro acidato verniciato, vetro trasparente. Telaio e maniglia dedicata in metallo Canna di Fucile. Narcisse è disponibile con apertura battente. L'apertura dell'anta è dotata di due cerniere dedicate e ammortizzate, incassate nel basamento e nel coperchio.

Narcisse, a combination between metal and glass. Finish door in varnished glass, frosted varnished, transparent glass. Frame and handle Gun Metal finish. Narcisse as hinged doors. The door opening is fitted with specifically designed soft-closing hinges integrated in the base and cover.

Dimensioni ante mm / Doors dimensions inch

Battente - Hinged

L 396-476-556 H 2236-2396-2556 _ W 15 5/8"-18 6/8"-21 7/8" H 88"-94 3/8"-100 5/8"



DIVANI _ SOFAS

ARGO design Mauro Lipparini

Sistema divano, disponibile in versione fissa e componibile con struttura legno in multistrato rivestito da uno strato di poliuretano flessibile stampato con piedini in metallo finitura Canna di Fucile H 80 mm regolabili in maniera indipendente. Cuscino di seduta: poliuretano espanso sagomato a quote differenziate ricoperto in fibra di poliestere. Cuscino schienale: in fibra di poliestere e piuma sterilizzata, entrambi rivestiti in fodera di cotone, dotato di struttura in metallo finalizzata a migliorarne il comfort. Rivestimento in tessuto, ecopelle o pelle.

Sofa system, available in fixed and modular versions with plywood frame, clad with a flexible, printed polyurethane layer and furnished with independently adjustable feet of H 3 1/8", in metal Gun Metal finish. Seat cushion: moulded polyurethane foam of varying density, covered in polyester fibre. Back cushion: in polyester fibre and sterilised feathers, both covered in cotton lining, furnished with a metal frame designed to improve comfort. Cover in fabric, eco-leather or leather.



DIVANI / SOFAS

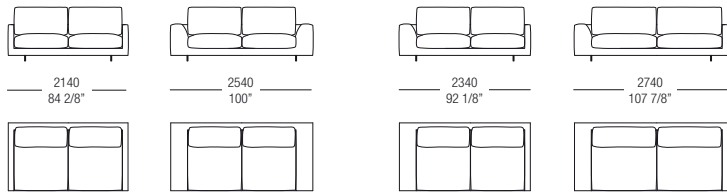

ELEMENTI COMPONIBILI / MODULAR ELEMENTS



chaise longue senza braccioli: centrostanza, terminali sx-dx o centrali
chaise longue without arms: central use, end units left-right and central units

angoli sx-dx / corner units left-right

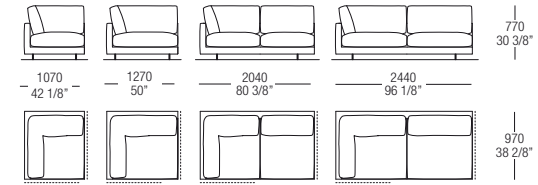

bracciolo / armrest

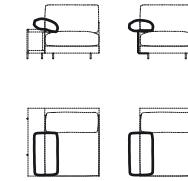

terminali ad angolo sx-dx / corner end units left-right

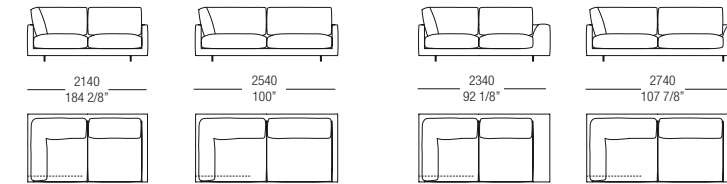

terminali sx-dx / end units left-right

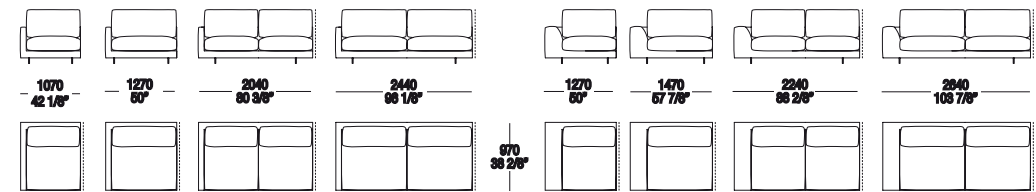

terminali senza braccioli: sx-dx o centrali / end units without arms: left-right or central units

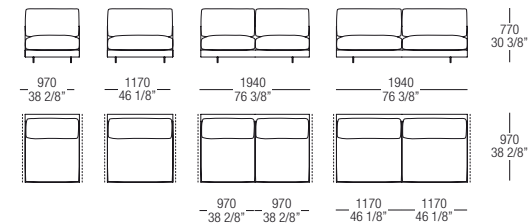

pouf terminali sx-dx / end units left-right

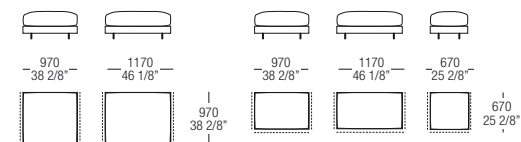

DIVANI _ SOFAS

ARGO design Mauro Lipparini

Tavolino e serie di librerie retro divano con struttura in tubolare di metallo finitura Canna di Fucile. Finiture: Laccato opaco; Laccato lucido; essenza Olmo Grey, Rovere Cenere, Rovere Fumé o Rovere Nero. Le retro librerie divano sono attrezzabili con cassetto e ribalta o a giorno e tavolino basso.

Small table and series of freestanding sofa back tables with metal inserts in Gun Metal finish. Finishes: Matt Lacquer; Glossy Lacquer; veneered wood in Elm Grey, Oak Cenere, Oak Fumé and Oak Black. The freestanding sofa back tables that can be furnished with a drawer, with drop-leaf or open.

LIBRERIA RETRO DIVANO /
BOOKCASE TO BE PLACED AT THE BACK OF THE SOFA

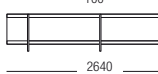
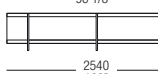
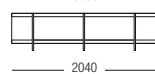
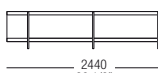
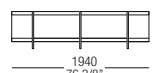
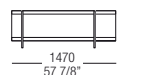
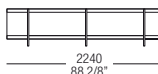
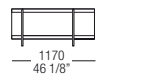
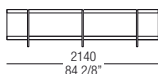
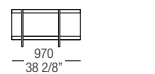
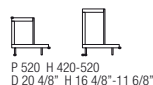
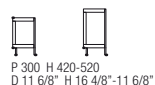

TAVOLINO / SMALL TABLE

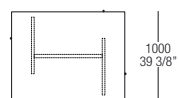
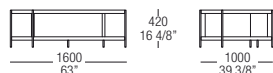

DIVANI _ SOFAS

MADISON design Mauro Lipparini

Divano a schema fisso, disponibile in tre larghezze. Base: pianale sagomato in multistrato con telaio in tubolare in metallo verniciato, rivestito con sagomato di poliuretano espanso ricoperto di vellutino. Scatolato di legno fissati alla base, ricoperti con poliuretano espanso sagomato a densità differenziata rivestiti in fibra con maglia poliestere. Cuscino di seduta: poliuretano espanso a densità differenziate rivestiti in fibra 200/400 gr con maglia poliestere. Rivestimento in tessuto, ecopelle o pelle.

Fixed-layout sofa, available in three widths. Base: moulded plywood platform with a painted, tubular metal frame, clad with moulded polyurethane foam covered in light velvet. Wooden boxed structure fixed to the base, covered with moulded polyurethane foam with variable density covered in polyester fibre. Seat cushion: multiple density polyester foam covered in 200 / 400 gram fibre with polyester mesh. Cover in fabric, eco-leather or leather.



ELEMENTI FISSI / FIXED SOFA

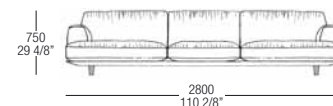
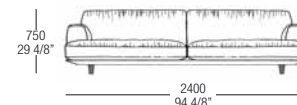
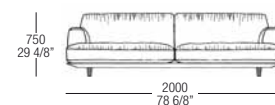

DIVANI _ SOFAS

PHOENIX design Mauro Lipparini

Phoenix è un sistema divano dalle molteplici combinazioni compositive caratterizzato da braccioli a incastro terminali e centrali inseribili nei moduli, che non prevedono il bracciolo alto strutturale; sono fissati al basamento dell'elemento sagomando le cuscinate di seduta per alloggiarli integralmente. Disponibile in versione fissa e componibile, comprende elementi centrali senza bracciolo, elementi ad angolo e terminali, dormeuse, pouf e chaise longue. Tutti gli elementi, completamente sfoderabili, disponibili nelle molteplici larghezze e in due profondità 970/1200mm., sono liberamente abbinabili tra loro. Il progetto comprende elementi asimmetrici "Dormeuse" utilizzabili singolarmente oppure integrabili nel sistema divano, rendendo estremamente personalizzabile la progettazione. Le cuscinate sono sfoderabili. Il cuscino di seduta è in poliuretano espanso sagomato a quote differenziate e ricoperto in fibra di poliestere. Il cuscino schienale è in fibra di poliestere e piuma sterilizzata, entrambi in fodera di cotone.

Phoenix is a sofa system with multiple compositional combinations, is characterized by interlocking end and central armrests, which can be inserted into the modules that do not include the high structural armrest. They are fixed to the base of the element, shaping the seat cushions to fully accommodate them. Available in a fixed and modular version, includes central elements without an armrest, corner and end elements, a dormeuse, pouf and chaise longue. All the elements, which are completely removable and available in multiple widths and two depths (38 2/8"/47 2/8"), can be freely combined. The project includes asymmetric "Dormeuse" elements that can be used individually or integrated into the sofa system, making the design extremely customizable. The cushions are removable. The seat cushion is made of expanded polyurethane, shaped in different densities and covered with polyester fiber. The backrest cushion is made of polyester fiber and sterilized down, both with a cotton lining.



DIVANI FISSI / FIXED SOFAS

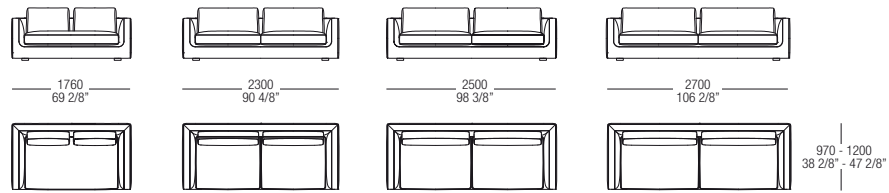

ELEMENTI COMPONIBILI / MODULAR ELEMENTS

chaise longue senza braccioli / Chaise longue without armrest

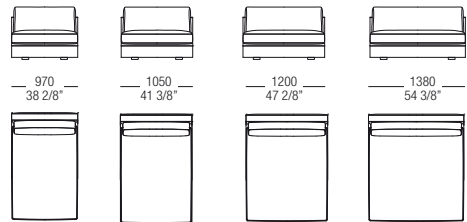

chaise longue con bracciolo sx-dx / chaise longue with left-right armrest

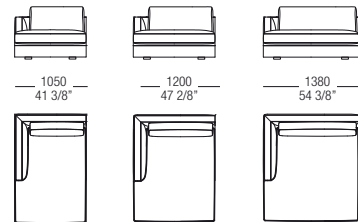

elementi centrali con schienale / central elements with backrest

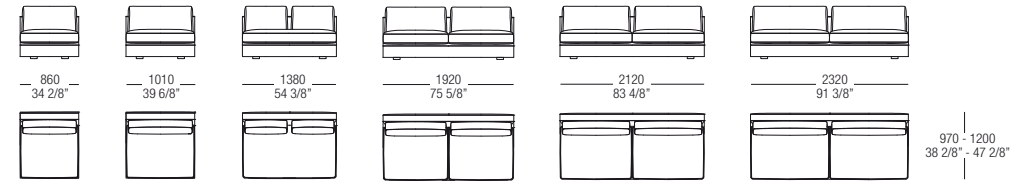

elementi centrali con schienale sx-dx / central elements with backrest left-right

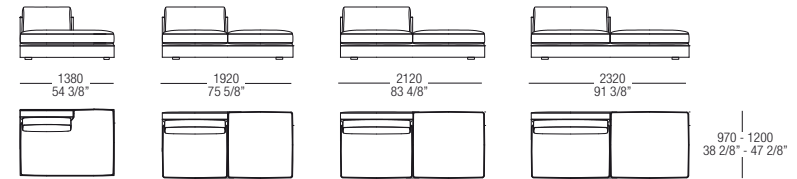

elementi terminali con schienale sx-dx / terminal elements with backrest left-right

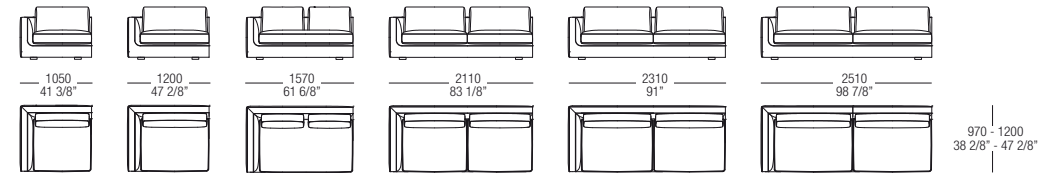

dormeuse con schienale sx-dx / dormeuse with backrest left-right

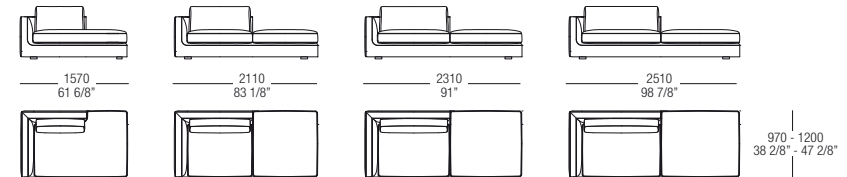

pouf centrali, terminali o angolo / central, end or corner element

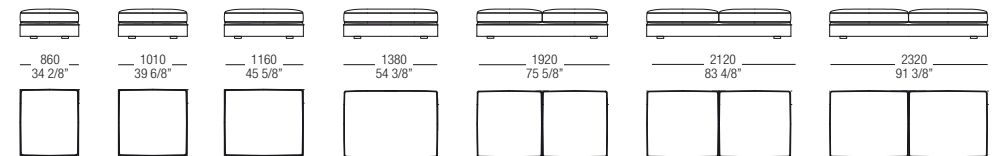

LETTI _ BEDS

COSY design Mauro Lipparini

Giroletto e testata imbottite con rivestimento in tessuto, similpelle e pelle. Possibilità di rivestire la fascia cornice della testata con tessuto o pelle, in finitura diversa dal rivestimento del letto. Possibilità base, con contenitore con rete alzabile due movimenti o con rete piana standard fissa in appoggio. Letto rifinito anche dietro, può essere utilizzato in centro stanza.

Bed frame and padded headboard with fabric, imitation leather and leather cover. The headboard's frame edge can be covered in fabric or leather, in a different finish to the finish of the bed. Option of a base with two-stage liftable bed base and standard, flat, fixed support base. Bed finished on all sides, can be positioned in the middle of the room.

Dimensioni letto mm / Bed dimensions inch

contenitore con rete alzabile / container with liftable mesh

L 1880-2080 P 2360 H 1130 _ W 74"-81 7/8" D 92 7/8" H 44 4/8" L 1600-1800 P 2000 _ W 63"-70 7/8" D 78 6/8"

giroletto con rete fissa - rete con movimento manuale o elettrico / rete cliente

frame with fixed mesh - mesh with manual or electric movement / customer mesh

L 1880-2080 P 2360 H 1130 _ W 74"-81 7/8" D 92 7/8" H 44 4/8" L 1600-1800 P 2000 _ W 63"-70 7/8" D 78 6/8"

L 1880-2080 P 2360 H 1130 _ W 74"-81 7/8" D 92 7/8" H 44 4/8" L 1600-1800 P 2100 _ W 63"-70 7/8" D 82 5/8"



MARGARETH design C. Marelli & M. Molteni

Giroletto e testata con rivestimento in tessuto, ecopelle, pelle o cuoio taglio al vivo. Struttura del letto in legno massello con piedi sagomati in rovere Fumè, Nero, Cenere e Olmo. La testata può essere rivestita in pelle supportata a taglio vivo per ottenere l'effetto cuoio in tutte le varianti di colore della pelle. Nel rivestimento della testata in tessuto, similpelle, pelle e velluto è previsto un bordo a contrasto in tinta con la struttura.

Bedframe and headboard with cover in fabric, ecoleather, leather or raw cut thick leather. Bedframe in solid wood with textured feet in oak finish Cenere, Fumè, Black and Elm. It is available also a version with supported leather headboard with thick leather-style stitching. The headboard with fabric, eco-leather, leather and velvet cover is adorned with a rim matching the bedframe.

Dimensioni letto mm / Bed dimensions inch

con rete fissa / frame with fixed mesh

L 1930 P 2280 H 1050 _ W 76" D 89 6/8" H 41 3/8"

Dimensioni materasso mm / Mattress dimensions inch

L 1750 P 2000 _ W 68 7/8" D 78 6/8"



LETTI _ BEDS

SUMO design Mauro Lipparini

Letto con testata imbottita rivestita in tessuto, ecopelle o pelle. La parte frontale della testata è caratterizzata da una trapuntatura effetto capitonné ed è possibile rivestirla con tessuto differente della parte posteriore e dal giroletto. Giroletto imbottito rivestito in tessuto, ecopelle o pelle sfoderabile. Letto rifinito anche dietro, può essere utilizzato in centro stanza.

Upholstered headboard with cover in fabric, ecoleather or leather. The frontside of the headboard is characterized by a capitonné effect. Two different tone-on-tone material choices are possible on headboard and bedframe. Bed finished on all sides, can be positioned in the middle of the room. Bed finished on all sides, can be positioned in the middle of the room.

Dimensioni letto mm / Bed dimensions inch

contenitore con rete alzabile / container with liftable mesh

L 1970-2170 P 2350 H 950 _ W 77 4/8"-85 3/8" D 92 4/8" H 37 3/8" L 1600-1800 P 2000 _ W 63"-70 7/8" D 78 6/8"

giroletto con rete fissa - rete con movimento manuale o elettrico / rete cliente

frame with fixed mesh - mesh with manual or electric movement / customer mesh

L 1970-2170 P 2350 H 950 _ W 77 4/8"-85 3/8" D 92 4/8" H 37 3/8" L 1600-1800 P 2000 _ W 63"-70 7/8" D 78 6/8"

L 1970-2170 P 2450 H 950 _ W 77 4/8"-85 3/8" D 96 4/8" H 37 3/8" L 1600-1800 P 2100 _ W 63"-70 7/8" D 82 5/8"

L 1970 P 2385 H 950 _ W 77 4/8" D 93 7/8" H 37 3/8"

L 1530 P 2020 _ W 60 2/8" D 79 4/8"



NICE design Ferruccio Laviani

Testata e base con intelaiatura in acciaio, imbottitura in poliuretano espanso schiumato. Rivestimento in tessuto, ecopelle o pelle. Piedi in massello rivesti nello stesso materiale del letto. Rete strutturale speciale e materasso dedicato. Letto rifinito su tutti i lati, può essere utilizzato anche al centro della stanza.

Headboard and bedframe in steel and sprayed polyuretane foam with front feet in solid wood. Cover in fabric, ecoleather or leather. Special structural slatted base and specially designed mattress. Bed finished on all sides, can be positioned in the middle of the room.

Dimensioni letto mm / Bed dimensions inch

con rete fissa / frame with fixed mesh

L 2100 P 2320 H 1050 _ W 82 5/8" D 91 3/8" H 41 3/8"

Dimensioni materasso mm / Mattress dimensions inch

L 1800 P 2000 _ W 70 7/8" D 78 6/8"



GRUPPI NOTTE _ NIGHT STANDS

LINDO design C. Marelli & M. Molteni

Gruppo notte in rovere Fumé o Nero. Top sagomato disponibile in Rovere Fumé, Rovere Nero oppure in marmo in tutte le varianti. Il comò è disponibile in due tipologie: con 5 cassetti o 6 cassetti. Il comodino ha la base in metallo finitura Canna di Fucile ed è dotato di ripiano in appoggio in essenza nella stessa finitura del cassetto. Cassetti con bordi per presa apertura.

Chest of drawers and bedside table in oak in finish Fumé, Black. Shaped top available in Oak Fumé, Oak Black or marble top in all variants. Chest of drawers available in two versions: with 5 drawers or 6 drawers. Drawers with edges as grip for opening.

Dimensioni mm / Dimensions inch

Comò 5 cassetti - Chest of drawers with 5 drawers L 1075 P 528 H 1010 _ W 42 3/8" D 20 6/8" H 39 6/8"

Comò 6 cassetti - Chest of drawers with 6 drawers L 1477 P 528 H 675 _ W 58 1/8" D 20 6/8" H 26 5/8"

Comodino - Bedside table

L 515 P 488 H 585 _ W 20 2/8" D 19 2/8" H 23"



KESSLER design Mauro Lipparini

Serie di tavolini con base in metallo finitura Satinato o Canna di Fucile. Piano legno in essenza Noce, Olmo Grey, Rovere Cenere, Rovere Fumé, Rovere Nero; Laccato Opaco; Laccato Lucido; vetro trasparente Naturale o Fumé; piano in marmo in tutte le varianti. Comodino con cassetto in MDF lavorato a 45° in essenza o laccato opaco e maniglia in metallo incassata.

A series of small tables with metal base in finishing Satined or Gun Metal. Top available in veneer Walnut, Elm Grey, Oak Cenere, Oak Fumé, Oak Black; Matt Lacquer; Glossy Lacquer; transparent glasses top in finish Natural or Fumé; marble top in all variants. Bedside table with drawer front cut at 45° in veneer finish or Matt Lacquer and incorporated metal handle.

Dimensioni mm / Dimensions inch

Tavolini - Small table L 420 P 420 H 360 _ W 16 4/8" D 16 4/8" H 14 1/8"

L 530 P 420 H 280 _ W 20 7/8" D 16 4/8" H 11"

L 590 P 420 H 360 _ W 23 2/8" D 16 4/8" H 14 1/8"

Comodino - Bedside table L 590 P 420 H 460 _ W 23 2/8" D 16 4/8" H 18 1/8"



GRUPPI NOTTE _ NIGHT STANDS

MILVIAN design Francesco Lucchese

Comò e comodini con struttura in essenza Noce, Olmo Grey, Rovere Cenere, Rovere Fumé, Rovere Nero. Spalle sagomate in alluminio verniciato Canna di Fucile o Bronzo. E' possibile anche la versione con frontale fisso per utilizzo bifacciale. Comò con top in essenza sp.10mm., Laccato Opaco, Laccato Lucido o marmo in tutte le varianti. Comodino disponibile in due dimensioni con cassetto in essenza sp.10mm., Laccato Opaco, Laccato Lucido o marmo in tutte le varianti, piano di appoggio superiore in vetro trasparente Naturale o Fumé. Cassetti con bordi per presa apertura.

Chest of drawers and bedside table, structure covered in wood veneer Walnut, Elm Grey, Oak Cenere, Oak Fumé, Oak Black. Sides in Aluminum painted Gun Metal or Bronze. Its possible option of two-sided fixed front. Chest of drawers with top in wood veneered in the same finish as the drawers or marble top in all variants. Bedside table available in two dimensions with drawer in wood veneered in the same finish as the drawers, top in wood veneered or marble, upper glass top transparent Natural, Fumé, Bronze. Drawers with edges as grip for opening.

Dimensioni mm / Dimensions inch

Comò - Chest of drawers L 1351 P 514 H 749 _ W 53 2/8" D 20 2/8" H 29 4/8"

Comodino - Bedside table L 711 P 514 H 485 _ W 28" D 20 2/8" H 19 1/8"

L 871 P 514 H 485 _ W 34 2/8" D 20 2/8" H 19 1/8"



PROSCENIO design Luca Scacchetti

Comò e comodini in essenza Rovere Fumé, Rovere Nero. Anta laterale ai cassetti con apertura push, posizionata a sinistra per il comò, sinistra o destra per il comodino; vano interno attrezzato con ripiano. Cassetti con fessura laterale per presa apertura. Piedi in metallo cromato.

Chest of drawers and bedside table, structure in wood veneer Oak Fumé, Oak Black. Side door to drawers with push opening, positioned on the left for the chest of drawers, left or right for the bedside table, internal space equipped with one shelf. Drawers with side slot for opening. Feet in chromed metal.

Dimensioni mm / Dimensions inch

Comò - Chest of drawers L 1350 P 545 H 682 _ W 53 1/8" D 21 4/8" H 26 7/8"

Comodino - Bedside table L 720 P 495 H 432 _ W 28 3/8" D 19 4/8" H 17"



COMPLEMENTI _ COMPLEMENTS

AR1 design Alfred Roth

Carrello Bar con struttura in tubolare d'acciaio satinato spazzolato e cromato Ø 20mm.; riserva ghiaccio in lamiera leggera saldata, contenitore per bottiglie in lamiera d'alluminio traforata; box contenitore con due antine ribaltabili in acero laccato finitura nero, interno in betulla naturale. Ruote raggiate in acciaio cromato con gomme rigide di colore bianco, piano estraibile in multistrato bordato di profilo d'acciaio e ricoperto in laminato plastico di colore nero. Accurata lavorazione artigianale. Pezzo storico numerato.

Trolley-Bar with structure in satinated brushed and chromed tubular steel Ø 20mm, container with two small flap doors in maple lacquered in a black colour, ice holder in light metal sheet and a bottle container in perforated aluminium. Wheels in chromed steel with rigid tyres in a white colour, pull-out top in multilayer panel with steel profile on the edges and covered in melamine in a black colour. Accurately handcrafted. Numbered historical piece.

Dimensioni mm / Dimensions inch

L 945 (1445) P 330 H 730 _ W 37 2/8" (56 7/8") D 13" H 28 6/8"



SOUL design CR&S MisuraEmme

Specchiera completa di aggancio a muro posizionabile in verticale oppure inclinata di 5°. Telaio perimetrale in massello di rovere Noce, Grey, Cenere, Fumé, Nero. Specchio finitura Naturale. Profili orizzontali in metallo.

Wall mirror complete with wall fixtures that can be fitted vertically or inclined 5°. Frame finishes in solid oak wood in Walnut, Grey, Cenere, Fumé, Black. Horizontal profiles in metal.

Dimensioni mm / Dimensions inch

L 880 P 40 H 1900 _ W 34 5/8" D 1 5/8" H 74 6/8"



COMPLEMENTI _ COMPLEMENTS

CUSCINI design CR&S MisuraEmme

Cuscini sfoderabili in diverse dimensioni. Imbottitura interna in piuma d'oca o espanso.

Removable cushions in several dimensions. Inner core in feathers or in foam.

Dimensioni mm / Dimensions inch

400 x 400 _ 15 6/8" x 15 6/8"

500 x 500 _ 19 5/8" x 19 5/8"

600 x 600 _ 23 5/8" x 23 5/8"

600 x 300 _ 23 5/8" x 11 6/8"



STONE design CR&S MisuraEmme

Pouf in diverse dimensioni con struttura interna rivestita con gomma comfort. Rivestimento esterno in tessuto sfoderabile con velcro oppure pelle o ecopelle sfoderabile da personale esperto.

Pouf in different dimensions with internal structure covered with comfort rubber upholstery. Covering in fabric applied with velcro removable or leather or ecoleather removable by skilled personnel.

Dimensioni mm / Dimensions inch

L 400 P 400 H 400 _ W 15 6/8" D 15 6/8" H 15 6/8"

L 1050 P 500 H 400 _ W 41 3/8" D 19 5/8" H 15 6/8"

L 1600 P 400 H 350 _ W 63 D 15 6/8" H 13 6/8"

Ø 500 H 400 _ Ø 19 5/8" H 15 6/8"

Ø 900 H 400 _ Ø 35 3/8" H 15 6/8"

Ø 1200 H 400 _ Ø 47 2/8" H 15 6/8"



COMPLEMENTI _ COMPLEMENTS

ELEGIE design Ignazio Gardella

Riedizione di un progetto di Ignazio Gardella del 1949, nonché uno dei primi progetti in assoluto che hanno precorso il concetto di componibilità. Il montante, perforato ogni 40mm. e completo di piastre e bulloni per l'ancoraggio a parete, è in metallo verniciato epossidico colore nero poggiante su una scarpetta in metallo cromato. Ripiani in due profondità con reggipiani in metallo cromato, realizzati in Laccato Opaco o essenza. Ripiani con profondità 460mm sono utilizzabili quali scrittoi, piani TV o attrezzature audiovisive. La componibilità in larghezza si realizza semplicemente grazie all'accostamento dei singoli moduli. Scaletta e sostegno scaletta in metallo verniciato nero con particolari in metallo cromato.

A reissue of a 1949 Ignazio Gardella design noted also for being one of the very first realizations that spearheaded the concept of modularity. Aluminium metal uprights, drilling holes every 40 mm. and complete with necessary fixtures to the wall, is in the black epoxy enamel finish on a chromed metal base. Shelves available in two depth with shelf holders in chromed metal, in Matt Lacquer or veneer. Shelves depth 460mm can be used as a desk, TV stand or to place HI-FI systems. Composition obtained by simply placing several modules next to each other. Lengthwise assemblability is obtained by simply placing several modules next to each other. Ladder in metal varnished black with details in chromed metal.



Dimensioni mm / Dimensions inch

ELEMENTI COMPONENTI / MODULAR ELEMENTS

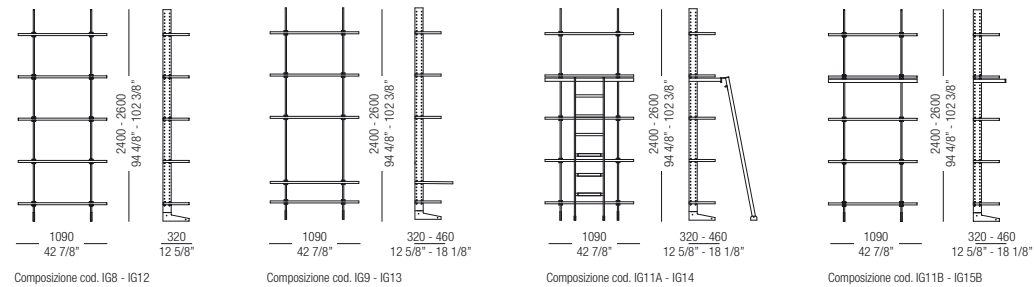

COMPLEMENTI _ COMPLEMENTS

WL2 design Wolfgang Laubersheimer

Tensolibreria in lamiera grezza d'acciaio spess.3mm. Finiture grigio metallizzato o verniciato ruggine. Cavo d'acciaio in tensione con redance. Pezzo storico numerato.

Bookshelf in untreated sheet-steel, thickness 1/8". Finishes metallic grey or lacquered in a rusty colour. Steel cable as straightening element. Numbered historical piece.

Dimensioni mm / Dimensions inch

L 410 P 310 H 2300 _ W 16 1/8" D 12 2/8" H 90 4/8"



MADIE _ SIDEBOARDS

NIBBIO design C. Marelli & M. Molteni

Madie disponibili in due tipologie: bassa e alta. Struttura esterna in Laccato Opaco o Laccato Lucido. Interno e top in Laccato Opaco nello stesso colore della finitura esterna. La base, in metallo è sostenuta da due traversi ancorati alle spalle. Madia in versione alta composta: parte inferiore con due ante battenti in legno e ripiano interno, nella parte superiore ante battenti in vetro con ripiano attrezzabile con luce LED integrata. La madia in versione bassa è composta due ante laterali battenti con cerniere ad incasso invisibile e anta centrale a ribalta con cassetto interno.

Sideboards available in two version: low and high. External finish in Matt Lacquer or Glossy Lacquer. Internal and top Matt Lacquer finish in the same color as the external finish. Base in metal, supported by two crossbars anchored to the side panels. High version can be furnished with two wood hinged door with internal shelf, can be upper two hinged glass doors with upper shelf with built-in LED. Low version furnished with two side hinged doors, with invisibile hinges incorporated.

Dimensioni mm / dimension in

Alta - High L 1300 P 516 H 1534 _ W 51 3/16" D 20 5/16" H 60 3/8"

Bassa - Low L 1908 P 516 H 880 _ W 75 1/8" D 20 5/16" H 34 5/8"



MADISON design Mauro Lipparini

Madia a parete o bifacciale con ante complanari: esterno in Ecopelle, interno ante Laccato Opaco o Laccato Lucido. Struttura esterna in finitura Laccato Opaco o Laccato Lucido. Top in Laccato Opaco, Laccato Lucido o marmo in tutte le varianti. Interno Laccato Opaco. Base e profili ante in metallo. È possibile attrezzarla con cassettiera interna e vassoio porta posate.

Sideboard wall mounted or two-sided units with coplanar doors in Ecoleather, door internal Matt Lacquer or Glossy Lacquer. External finish in Matt Lacquer or Glossy Lacquer. Top in Matt Lacquer, Glossy Lacquer or marble in all variants. Internal finish in Matt Lacquer. Base and door frame metal. Option for the addition of drawers and cutlery tray.

Dimensioni mm / Dimensions inch

L 2560 P 556 H 686 _ W 100 6/8" D 21 7/8" H 27"



MADIE _ SIDEBOARDS

KESSLER design Mauro Lipparini

Serie di madie disponibili in differenti dimensioni, materie e finiture. Disponibili in tre tipologie: a parete, bifacciali, sospese. Struttura e facciate in essenza, vetro trasparente o vetro riflettente. La struttura può avere una finitura diversa dai frontali. Interno e vani a giorno in nobilitato Ambiente o Laccato Opaco. Base, maniglia e telaio di struttura in metallo.

Series of sideboards are available in different dimensions, materials and finishes. Available in three types: wall mounted units, two-sided units, hanging. Frame and doors in veneer, transparent or reflecting glass. The frame can have a different finish to the front. Interior and compartments in laminated Ambiente or in Matt Lacquer. Metal base, handles and frame in metal.

Dimensioni mm / Dimensions inch

Kessler 01 parete - wall mounted L 976 P 517 H 1526 _ W 38 3/8" D 20 3/8" H 60 1/8"
bifacciale - two-sided L 976 P 538 H 1526 _ W 38 3/8" D 21 1/8" H 60 1/8"

Kessler 03 vetrina - showcase L 976 P 513 H 1526 _ W 38 3/8" D 20 2/8" H 60 1/8"

Kessler 02 parete - wall mounted L 1296 P 517 H 1526 _ W 51" D 20 3/8" H 60 1/8"
bifacciale - two-sided L 1296 P 538 H 1526 _ W 51" D 21 1/8" H 60 1/8"

Kessler 04 parete - wall mounted L 1616 P 517 H 1046 _ W 63 5/8" D 20 3/8" H 41 1/8"
bifacciale - two-sided L 1616 P 538 H 1046 _ W 63 5/8" D 21 1/8" H 41 1/8"

Kessler 05 parete - wall mounted L 1936 P 517 H 726 _ W 76 2/8" D 20 3/8" H 28 5/8"
bifacciale - two-sided L 1936 P 538 H 726 _ W 76 2/8" D 21 1/8" H 25 5/8"

Kessler 06 sospesa - suspended L 1932 P 517 H 406 _ W 76 1/8" D 20 3/8" H 16"



Kessler 01

Kessler 03

Kessler 02

Kessler 04



Kessler 05

Kessler 06

TAVOLI _ TABLES

ALA design Ferruccio Laviani

Tavolo con base legno in finitura essenza Olmo Grey, Rovere Fumé, Rovere Nero o laccato opaco. Piano sagomato disponibile in due varianti: semiovale con piano in marmo in tutte le varianti o piano in vetro trasparente Naturale o Fumé; piano rotondo in marmo con sottopiano in essenza in finitura come base. Per il piano rotondo è prevista l'opzione di un piano sagomato girevole in marmo (Lazy Susan) in appoggio sul piano centrale, disponibile in due dimensioni.

Table with wooden base in veneered finishing Elm Grey, Oak Fumé, Oak Black or matt lacquer finish. Moulded top available in versions: oval top available in marble top in all variants or in transparent glass Natural or Fumé; round top available in moulded marble and undertop in moulded wood with the same finish as the base. For the round top available an optional revolving moulded top in marble (Lazy Susan), supporting on the central top, available in two dimensions.

Dimensioni mm / Dimensions inch

Semiovale - Semi-oval L 2500 P 1030 H 745 _ W 98 3/8" D 40 4/8" H 29 3/8"

L 2800 P 1030 H 745 _ W 110 2/8" D 40 4/8" H 29 3/8"

Rotondo - Round Ø 1550 H 745 _ Ø 61" H 29 3/8"

Ø 1650 H 745 _ Ø 65" H 29 3/8"



GAUDI design Ferruccio Laviani

Tavolo con base artigianale in massello di rovere Cenere, Fumé o Nero. Piano semiovale sagomato disponibile in tre dimensioni, nelle finiture: essenza Rovere Cenere, Rovere Fumé, Rovere Nero o in marmo in tutte le varianti. A richiesta, è possibile avere piani in lunghezza su misura, a partire da L 1900 mm.

Table handcrafted with base in solid wood oak Cenere, Fumé or Black. Semi-oval top available in three dimensions, in the finishing: veneer Oak Cenere, Oak Fumé, Oak Stained or in marble top in all variants. On request, tops cut to measure in length, minimum W 74 6/8".

Dimensioni mm / Dimension inch

L 2300 P 1000 H 730 _ W 90 4/8" D 39 3/8" H 28 6/8"

L 2500 P 1000 H 730 _ W 98 3/8" D 39 3/8" H 28 6/8"

L 2800 P 1000 H 730 _ W 110 2/8" D 39 3/8" H 28 6/8"



TAVOLI _ TABLES

GRAMERCY design Mauro Lipparini

Tavolo con base artigianale in massello finitura essenza Olmo Grey, Rovere Cenere, Rovere Fumé, Rovere Nero. Piano semiovale sagomato con distanziatori cilindrici in acciaio satinato. Dimensioni L 2400 / L 2650 con piano in vetro trasparente Naturale o Fumé. Nella dimensione L2650mm è disponibile con piano in essenza e sottopiano sagomato Laccato Opaco o Laccato Lucido; con piano e sottopiano nello stesso colore Laccato Opaco o Laccato Lucido; nella versione bicolore con piano e sottopiano Laccato Lucido in 2 colori differenti.

Table handcrafted with base in solid wood veneer finishing Elm Grey, Oak Cenere, Oak Fumé, Oak Black. Semi-oval shaped top with cylindrical spacers in satined steel. Dimensions W 94 4/8" / W 104 3/8" with top in tempered glass Natural or Fumé. Dimension W 104 3/8" is available with top in veneer and shaped undertop moulded under top Matt Lacquer or Glossy Lacquer; top and undertop Matt Lacquered or Glossy Lacquered in the same finish; version two color with top and undertop in Glossy Lacquer in two different colours.

Dimensioni mm / Dimension inch

L 2400 P 1100 H 735 _ W 94 4/8" D 43 2/8" H 28 7/8"

L 2650 P 1100 H 735 _ W 104 3/8" D 43 2/8" H 28 7/8"



BELLAFONTE design Mauro Lipparini

Tavolo con base in metallo cromato. Piano rotondo in vetro trasparente Naturale o Fumé, disponibile in tre dimensioni.

Table with chrome metal base. Round top in transparent glass Natural or Fumé, available in three dimensions.

Dimensioni mm / Dimensions inch

Ø 1300 H 740 _ Ø 51 1/8" H 29 1/8"

Ø 1400 H 740 _ Ø 55 1/8" H 29 1/8"

Ø 1500 H 740 _ Ø 59 1/8" H 29 1/8"



TAVOLI _ TABLES

LONG ISLAND design CR&S MisuraEmme / Mauro Lipparini

Tavolo rettangolare nelle finiture: Laccato Opaco, Laccato Lucido o in essenza Noce, Olmo Grey, Rovere Cenere, Rovere Fumé, Rovere Tinto Nero. A richiesta, è possibile avere piani su misura: L max 3000 mm., P max 1000 mm.

Rectangular table in the finishing: Matt Lacquer, Glossy Lacquer or in venerated Walnut, Elm Grey, Oak Cenere, Oak Fumé, Oak Stained Black. On request, tops cut to measure in: max W 118 1/8", max D 39 3/8".

Dimensioni mm / Dimensions inch

L 1800 P 900 H 740 _ W 70 7/8" D 35 3/8" H 29 1/8"

L 2200 P 900 H 740 _ W 86 5/8" D 35 3/8" H 29 1/8"

L 2400 P 900 H 740 _ W 94 4/8" D 35 3/8" H 29 1/8"



VIRGO design Mauro Lipparini

Serie composta da tavolo, consolle, scrivania. Base in metallo finitura Satinato, Canna di fucile. Piano semiovale sagomato disponibile nelle finiture: Laccato Opaco, Laccato Lucido o in essenza Noce, Olmo Grey, Rovere Cenere, Rovere Fumé, Rovere Nero. A richiesta, è possibile avere il piano del tavolo in lunghezza su misura, a partire da L 1700 mm.

Serie composed by table, console, writing-desk. Metal base in finish Satined, Gun Metal. Shaped semi-oval top, available in venerated Walnut, Elm Grey, Oak Cenere, Oak Fumé, Oak Black. On request, for an extra charge, tops are available in different sizes down to a minimum W 66 7/8".

Dimensioni mm / Dimension inch

Tavolo - Table L 2400 P 1000 H 730 _ W 94 4/8" D 39 3/8" H 28 6/8"

Consolle L 2000 P 610 H 730 _ W 78 6/8" D 24" H 28 6/8"

Scrittorio - Writing-desk L 1700 P 770 H 730 _ W 66 7/8" D 30 3/8" H 28 6/8"



TAVOLI _ TABLES

TAUL design Mauro Lipparini

Tavolo in varie forme e dimensioni con gambe in alluminio Satinato o Canna di Fucile oppure in metallo Laccato Opaco. Piano in vetro trasparente Naturale o Fumé. A richiesta, è possibile avere piani su misura.

Table of various shapes and sizes with satin-finish aluminium, gunmetal or matt lacquered metal legs. Transparent glass finish Natural or Fumé top. Tops in tailor-made sizes on request.

Dimensioni mm / Dimensions inch

Quadrato - Square L 1200 P 1200 H 736 _ W 47 2/8" D 47 2/8" H 29"

L 1400 P 1400 H 736 _ W 55 1/8" D 55 1/8" H 29"

L 1600 P 1600 H 736 _ W 63" D 63" H 29"

Rettangolare - Rectangular L 1600 P 900 H 736 _ W 63" D 35 3/8" H 29"

L 1800 P 900 H 736 _ W 70 7/8" D 35 3/8" H 29"

L 2000 P 900 H 736 _ W 78 6/8" D 35 3/8" H 29"

L 2200 P 900 H 736 _ W 86 5/8" D 35 3/8" H 29"

L 2400 P 900 H 736 _ W 94 4/8" D 35 3/8" H 29"

L 2600 P 900 H 736 _ W 102 3/8" D 35 3/8" H 29"

Rotondo - Round Ø 1400 H 736 _ Ø 55 1/8" H 29"

Ø 1600 H 736 _ Ø 63" H 29"

Ovale - Oval L 2300 P 1050 H 736 _ W 90 4/8" D 41 3/8" H 29"

L 2500 P 1050 H 736 _ W 98 3/8" D 41 3/8" H 29"

L 2700 P 1050 H 736 _ W 106 2/8" D 41 3/8" H 29"



POLTRONE _ ARMCHAIRS

ERMES design Mauro Lipparini

Poltrone e pouf con scocca in poliuretano schiumato a freddo. Rivestimento in tessuto, ecopelle o pelle. Poltrone disponibili in tre varianti: base fissa in massello di rovere Noce, Olmo Grey, Rovere Cenere, Rovere Fumé, Rovere Nero; base girevole in acciaio in metallo; Ermes Vesta con base in metallo rivestita in tessuto. E' possibile rivestire la parte frontale della poltrona con tessuto diverso dal retro.

Armchairs and pouf with cold-processed polyurethane body. Cover in fabric, ecoleather or leather. Available in three variations: wood fixed base in solid oak finishing Walnut, Elm Grey, Oak Cenere, Oak Fumé, Oak Black; swivel base in satined stainless steel; Ermes Vesta metal base with fabric cover. The front of the armchair can be covered in a different textile to the rear.

Dimensioni mm / Dimensions inch

Base fissa legno - Wood fixed base L 780 P 900 H 950 _ W 30 6/8" D 35 3/8" H 37 3/8"

Base girevole metallo - Metal swivel base L 780 P 900 H 950 _ W 30 6/8" D 35 3/8" H 37 3/8"

Ermes Vesta L 780 P 900 H 950 _ W 30 6/8" D 35 3/8" H 37 3/8"

Pouf L 630 P 450 H 370 _ W 24 6/8" D 17 7/8" H 14 5/8"



FLORENTIA design Mauro Lipparini

Poltrone con scocca in poliuretano schiumato a freddo. Rivestimento in tessuto, ecopelle o pelle. Poltrone disponibili in due varianti: base con lavorazione artigianale in massello di rovere Noce, Olmo Grey, Rovere Cenere, Rovere Fumé, Rovere Nero; base fissa in metallo nickel satinato. E' possibile rivestire la parte frontale della poltrona con tessuto diverso dal retro.

Armchairs with cold-processed polyurethane body. Cover in fabric, ecoleather or leather. Available in two variations: Base in solid wood with artisan craftsmanship in oak Walnut, Elm Grey, Oak Cenere, Oak Fumé, Oak Black; satined nickel metal fixed base. The front of the armchair can be covered in a different textile to the rear.

Dimensioni mm / Dimensions inch

Base fissa legno - Wood fixed base L 690 P 830 H 780 _ W 27 1/8" D 32 5/8" H 30 6/8"

Base fissa metallo - Metal fixed base L 690 P 830 H 780 _ W 27 1/8" D 32 5/8" H 30 6/8"



POLTRONE _ ARMCHAIRS

OPERA design Mauro Lipparini

Poltrona e Dinner Chair con scocca e piedi in poliuretano schiumato a freddo e schienale rivestito in fibra di dracron. Rivestimento in tessuto, ecopelle, ecopelle o pelle. Schienale con cuciture plissé. Dinner Chair è montata su una serie di ruote piroettanti. E' possibile rivestire la parte frontale della poltrona con tessuto diverso dal retro.

Armchair and Dinner Chair with body and feet in cold-foamed polyurethane and Dacron-fibre lined back. Covered in fabric, ecoleather or leather. Backrest with ruffled seams. The dinner chair is mounted on a series of rotating wheels. The front of the armchair can be covered in a different textile to the rear.

Dimensioni mm / Dimensions inch

Poltrona - Armchair L 740 P 820 H 720 _ W 29 1/8" D 32 2/8" H 28 3/8"

Dinner Chair L 630 P 570 H 810 _ W 24 6/8" D 22 4/8" H 31 7/8"



QUADRIA design Mauro Lipparini

Poltrona con struttura in massello di rovere tinto Noce, Grey, Cenere, Fumé, Nero. Cuscini seduta e schienale in poliuretano espanso a quote differenziate e piuma con prerinvestimento in tela cotone. Rivestimento sfoderabile in tessuto, ecopelle o pell.

Structure in solid oakwood finishes oak stained Walnut, Grey, Fumé, Cenere, Black. Seat and back cushion in polyurethane foam of different densities and feathers with lined in cotton canvas, covered removable in fabric, ecoleather or leather.

Dimensioni mm / Dimensions inch

L 790 P 770 H 700 _ W 31 1/8" D 30 3/8" H 27 4/8"



POLTRONE _ ARMCHAIRS

SUPER HELLA design Mauro Lipparini

Poltrona con scocca in poliuretano schiumato a freddo, struttura in metallo cromato, braccioli in cuoio nero. Rivestimento seduta in tessuto, ecopelle o pelle.

Armchair with structure cold sprayed polyurethane foam, frame in chromed metal, armrests in black thick leather. Seat covered in fabric, ecoleather or leather.

Dimensioni mm / Dimensions inch

L 830 P 750 H 720 _ W 32 5/8" D 29 4/8" H 28 3/8"



SURFACE design Marco Piva

Poltrona con scocca in poliuretano schiumato a freddo. Rivestimento in tessuto, ecopelle o pelle. E' possibile rivestire schienale frontale e seduta con tessuto diverso dal retro.

Armchair with cold-processed polyurethane body. Covered in fabric, ecoleather or leather. The back front and seat of the armchair can be covered in a different textile to the rear.

Dimensioni mm / Dimensions inch

L 610 P 580 H 730 _ W 24" D 22 7/8" H 28 6/8"



POLTRONE _ ARMCHAIRS

VIOLETTA design Mauro Lipparini

Poltrona con scocca in poliuretano schiumato a freddo. Rivestimento in tessuto, ecopelle o pelle, rivestimento retro poltrona sempre in cuoio. Base girevole in metallo Canna di Fucile. Seduta con cinghia di tenuta. E' possibile rivestire la parte frontale della poltrona con tessuto diverso dal retro.

Armchair with cold-foamed polyurethane body. Cover in fabric, ecoleather or leather; rear always in hide cover. Revolving metal base in gunmetal. Seating with grip belt. The front of the armchair can be covered in a different textile to the rear.

Dimensioni mm / Dimensions inch

L 800 P 750 H 790 mm _ W 31 4/8" D 29 4/8" H 31 1/8"



WM design Werner Max Moser

Poltrona e pouf con struttura tubolare cromato. Braccioli in massello di legno laccato nero. Cuscino seduta e cuscino schienale in espanso con rinforzo in multistrati. Rivestimento in tessuto, ecopelle o pelle. Pezzo numerato.

Armchair and pouf with tubular structure in chrome. Armrests in solid wood black lacquered. Seat and backrest cushions in polyurethane foam reinforced with multilayer. Cover in fabric, ecoleather or leather. Numbered piece.

Dimensioni mm / Dimensions inch

Poltrona - Armchair L 600 P 770 H 700 _ W 23 5/8" D 32 5/8" H 32 2/8"

Pouf L 540 P 540 H 430 _ W 21 2/8" D 21 2/8" H 16 7/8"



SEDIE _ CHAIRS

ALINA design Allievi + Viganò

Poltrona con struttura in massello laccato opaco o laccato lucido. Sedile imbottito rivestito in tessuto, ecopelle, pelle o Nabuk. Schienale in curvato rivestito cuoio.

Armchair with frame in matt or glossy lacquered solid wood. Padded seat cover in fabric, ecoleather, leather or Nubuk. Thick leather covered, curved back. Covered removable by expert personnel.

Dimensioni mm / Dimensions inch

L 520 P 500 H 800 _ W 20 4/8" D 19 5/8" H 31 4/8"



ARCHETTO design Mauro Lipparini

Sedie con scocca in poliuretano schiumato a freddo, rivestito in tessuto, ecopelle, pelle, Nabuk o cuoio. E' possibile rivestire la parte frontale della sedia con tessuto diverso dal retro. Disponibili in due varianti: base fissa legno in massello di rovere: Noce, Grey, Cenere, Fumé, Nero; base girevole in Alluminio lucido o metallo Canna di Fucile.

Chairs with cold-processed polyurethane body, covered in fabric, ecoleather, leather, Nubuck or thick leather. The front of the armchair can be covered in a different textile to the rear. Available in two variations: wood fixed base in oak Walnut, Grey, Cenere, Fumé, Black; swivel base in Glossy satin-finish Aluminum or Gun Metal.

Dimensioni mm / Dimensions inch

Base fissa legno - Wood fixed base

L 600 P 550 H 830 _ W 23 5/8" D 21 5/8" H 32 5/8"

Base girevole metallo - Swivel metal base

L 600 P 550 H 830 _ W 23 5/8" D 21 5/8" H 32 5/8"



SEDIE _ CHAIRS

BERTHA design C. Marelli & M. Molteni

Struttura e schienale curvato anatomico in massello di frassino Cenere, Nero. Sedile imbottito e rivestito in tessuto, ecopelle, pelle o Nabuk. Disponibile in due versioni: senza braccioli e con braccioli.

Structure and ash-clad curved back in solid wood Cenere, Black. Padded seat in fabric, ecoleather, leather or Nabuk. Available in two versions: without armrests and with armrests.

Dimensioni mm / Dimensions inch

Senza braccioli - Without armrests L 470 P 510 H 810 _ W 18 4/8" D 20 1/8" H 31 7/8"

Con braccioli - With armrests L 580 P 510 H 810 _ W 22 7/8" D 20 1/8" H 31 7/8"



CLEO' design CR&S MisuraEmme

Sedie con sedile e schienale in curvato imbottito e rivestito in tessuto, ecopelle, pelle o Nabuk. Base legno in massello di rovere: Noce, Grey, Cenere, Fumé, Nero.

Chairs with cold-processed polyurethane body, covered in fabric, ecoleather, leather or Nubuck. Wood fixed base in oak Walnut, Grey, Cenere, Fumé, Black.

Dimensioni mm / Dimensions inch

Bassa - Low L 530 P 510 H 760 _ W 20 7/8" D 20 1/8" H 29 7/8"

Alta - High L 530 P 570 H 920 _ W 20 7/8" D 22 4/8" H 36 2/8"



SEDIE _ CHAIRS

NAOS design Mauro Lipparini

Sedie con scocca in poliuretano schiumato a freddo, rivestito in tessuto, ecopelle, pelle, Nabuk o cuoio. E' possibile rivestire la parte frontale della sedia con tessuto diverso dal retro. Disponibile in due varianti: base fissa legno in massello di rovere: Noce, Grey, Cenere, Fumé, Nero; base girevole in Alluminio lucido o metallo Canna di Fucile.

Chairs with cold-processed polyurethane body, covered in fabric, ecoleather, leather, Nubuck or thick leather. The front of the armchair can be covered in a different textile to the rear. Available in two variations: wood fixed base in oak Walnut, Grey, Cenere, Fumé, Black; swivel base in Glossy satin-finish Aluminium or Gun Metal.

Dimensioni mm / Dimensions inch

Base fissa legno - Wood fixed base L 620 P 570 H 800 _ W 24 3/8" D 22 4/8" H 31 4/8"

Base girevole metallo - Swivel metal base L 620 P 570 H 800 _ W 24 3/8" D 22 4/8" H 31 4/8"



MICHELLE design Mauro Lipparini

Sedie con scocca in poliuretano schiumato a freddo, rivestito in tessuto, ecopelle, pelle, Nabuk. E' possibile rivestire la parte frontale della sedia con tessuto diverso dal retro. Disponibili in due varianti: base fissa legno in massello di rovere: Noce, Grey, Cenere, Fumé, Nero; base girevole in Alluminio lucido o metallo Canna di Fucile.

Chairs with cold-processed polyurethane body, covered in fabric, ecoleather, leather, Nubuck. The front of the armchair can be covered in a different textile to the rear. Available in two variations: wood fixed base in Oak Walnut, Grey, Cenere, Fumé, Black; swivel base in Glossy satin-finish Aluminum or Gun Metal.

Dimensioni mm / Dimensions inch

Base fissa legno - Wood fixed base L 510 P 600 H 830 _ W 20 1/8" D 23 5/8" H 32 5/8"

Base girevole metallo - Swivel metal base L 510 P 600 H 830 _ W 20 1/8" D 23 5/8" H 32 5/8"



TAVOLINI _ SMALL TABLES

RING design Mauro Lipparini

Serie di tavolini con struttura in metallo Satinato o Canna di Fucile. Piano in appoggio sui supporti della struttura nelle finiture: Vetro Verniciato; Vetro Acidato Verniciato; Vetro Trasparente; Vetro Acidato; marmo in tutte le varianti. Disponibile in tre dimensioni.

Series of small tables with structure in metal finish Satined or Gun Metal. Top resting on the supports of the structure available in finish: Varnished Glass; Frosted Varnished Glass; Transparent Glass; Frosted Glass; marble in all variants. Available in three dimensions.

Dimensioni mm / Dimensions inch

Ø 750 H 360 _ Ø 29 4/8" H 14 1/8"

Ø 500 H 360 _ Ø 19 5/8" H 14 3/16"

Ø 500 H 500 _ Ø 19 5/8" H 19 5/8"



SUSHI design Mauro Lipparini

Tavolini con base in metallo Satinato o Canna di Fucile. Piano d'appoggio a vassoio leggermente ribassato in finitura Laccato Opaco; piano d'appoggio liscio in finitura Laccato Lucido.

Small tables with metal base in finish Satined or Gun Metal. Slightly lowered trays top in finish Matt Lacquer; lowered smooth top in Glossy Lacquer.

Dimensioni mm / Dimensions inch

Ø 1000 H 355 _ Ø 39 3/8" H 14"

Ø 405 H 350 _ Ø 16" H 13 6/8"

Ø 405 H 480 _ Ø 16" H 18 7/8"



TAVOLINI _ SMALL TABLES

ANTIBES design Ferruccio Laviani

Tavolino con struttura in massello di rovere Noce, Grey, Cenere, Fumé, Nero. Piano in marmo Bianco Carrara Matt, Calacatta Oro Matt, Emperador Matt, Travertino Matt, Basaltite Matt, Grey Stone Glossy, Marquinia Glossy, Sahara Noir Glossy.

Structure in solid wood in oak Walnut, Grey, Cenere, Fumé, Black. Marble top in Bianco Carrara Matt, Calacatta Oro Matt, Emperador Matt, Travertino Matt, Basaltite Matt, Grey Stone Glossy, Marquinia Glossy, Sahara Noir Glossy.

Dimensioni mm / Dimensions inch

L 1000 P 1000 H 240 _ W 39 3/8" D 39 3/8" H 9 4/8"



HILL design Mauro Lipparini

Serie di tavolini con base in massello in finitura essenza Noce, Olmo Grey, Rovere Cenere, Rovere Fumé, Rovere Nero. Piano in finitura essenza Noce, Olmo Grey, Rovere Cenere, Rovere Fumé, Rovere Nero; Laccato Opaco; Laccato Lucido; piano in pelle; piano in marmo in tutte le varianti.

Series of small tables with solid wood base in veneer Walnut, Elm Grey, Oak Cenere, Oak Fumé, Oak Black. Top in veneer Walnut, Elm Grey, Oak Cenere, Oak Fumé, Oak Black; Matt Lacquer; Glossy Lacquer; top in leather; marble top in all variants.

Dimensioni mm / Dimensions inch

Rotondo basso - Low round Ø 520 H 370 _ Ø 20 4/8" H 14 5/8"

Rotondo alto - High round Ø 520 H 500 _ Ø 20 4/8" H 19 5/8"

Quadrato basso - Low square L 450 P 450 H 370 _ W 17 7/8" D 17 7/8" H 14 5/8"

Quadrato alto - High square L 450 P 450 H 500 _ W 17 7/8" D 17 7/8" H 19 5/8"



TAVOLINI _ SMALL TABLES

GRAMERCY design Mauro Lipparini

Serie di tavolini con base in massello con lavorazione artigianale in finitura essenza Olmo Grey, Rovere Cenere, Rovere Fumé, Rovere Nero. Piano in legno con sottopiano sagomato, disponibile nelle finiture: essenza Olmo Grey, Rovere Cenere, Rovere Fumé, Rovere Nero con sottopiano Laccato Opaco o Laccato Lucido; piano e sottopiano Laccato Opaco; piano e sottopiano Laccato Lucido; piano in vetro trasparente Naturale, Fumé, Bronzo; piano in marmo in tutte le varianti. Piano distanziato dalla base con distanziatori cilindrici in acciaio satinato.

Series of small tables with solid wood base in solid wood with artisan craftsmanship finishing in veneer Elm Grey, Oak Cenere, Oak Fumé, Oak Black. Wood top with shaped undertop, available in the finishes: veneer Elm Grey, Oak Cenere, Oak Fumé, Oak Black with moulded under top Matt Lacquer or Glossy Lacquer; top and undertop Matt Lacquered; top and undertop Glossy Lacquered; transparent glass top in finish Natural, Fumé, Bronze; marble top in all variants. Top with separated from the base by a series of satin-finish steel spacers.

Dimensioni mm / Dimensions inch

Sidetable basso - low Ø 380 H 405 _ Ø 15" H 16"

Sidetable alto - high Ø 550 H 500 _ Ø 21 5/8" H 19 5/8"

Round Ø 1250 H 355 _ Ø 49 2/8" H 14"

Square L 1200 P 1200 H 355 _ W 47 2/8" D 47 2/8" H 14"

Triangular L 1700 P 1300 H 305 _ W 66 7/8" D 51 1/8" H 12"



MOAI design Riccardo Gussoni

Tavolino in massello di tiglio disponibile nelle finiture Verniciato Bronzo Anticato, Laccato Opaco o Laccato Lucido.

Small table in solid lime wood Painted Antiqued Bronze, Matt Lacquer or Glossy Lacquer.

Dimensioni mm / Dimensions inch

Ø 350 H 460 _ Ø 13 6/8" H 18 1/8"



CREDITS

Concept, Art direction _ **MisuraEmme®** studio

Photography _ **Michele Poli Mascheroni**

Styling _ **Studio Rossella Battaglia & MisuraEmme®** studio

Printing _ **Pigini Group Printing Division** Tecnostampa® Loreto – Trevi

Copyright _ **MisuraEmme®**

Thanks to

ILLULIAN

ARTEMIDE

OLUCE

PENTA

NAHOOR

VENICEM

TERZANI

NEMO

DE VECCHI

GREGGIO

MEDLARS

MOTTADELLI

MAISON FIRE

IVV

Made in Italy - ODB0AH

MisuraEmme® S.p.A.

Via IV Novembre, 72

22066 Mariano Comense (CO)

Tel. +39 031.754111

Fax. +39 031.744437

info@misuraemme.it

www.misuraemme.it



The mark of
responsible forestry

Cerca prodotti certificati
FSC®



MisuraEmme® si riserva il diritto di apportare ogni modifica mirata al miglioramento funzionale e qualitativo dei propri prodotti. Testi e disegni presenti in questo stampato hanno scopo divulgativo, per ogni aspetto tecnico e dimensionale fare riferimento ai listini aziendali e relativi aggiornamenti.

MisuraEmme® reserves the right at all time to apply modifications for the functional or qualitative improvement of its products. Text and drawings present in this brochure have a divulgative purpose, for every technical and dimensional aspect please refer to the company's price lists and their relative updatings.

