

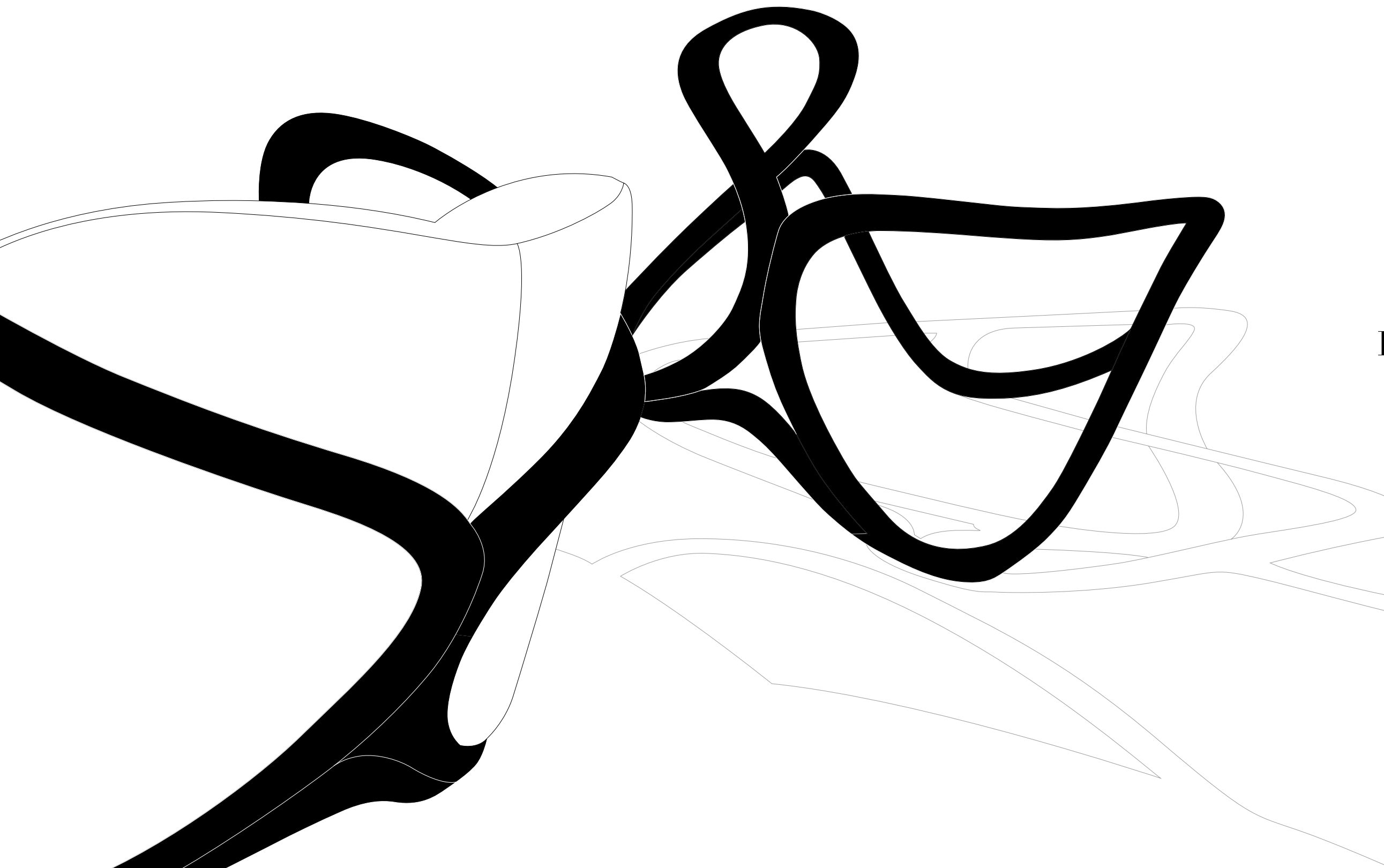

**GIORGETTI** 





In principio era questo verbo. Un gesto storico, ancestrale, fondatore. Le abili e pazienti mani degli artigiani plasmano il legno negli stabilimenti Giorgetti fin dalla fondazione dell'azienda a Meda, nel cuore della Brianza, nel 1898. Oggi Giorgetti produce collezioni di sedute, tavoli, librerie, letti e complementi firmati da importanti progettisti, alcune delle cui collaborazioni sono nate alla fine degli anni 80 e hanno permesso di creare prodotti funzionali, contemporanei e dallo stile atipico e inconfondibile, in grado di conciliare la più alta tradizione ebanistica con l'impiego di sofisticate tecnologie produttive.

Creatività e design caratterizzano i mobili Giorgetti, dando forma ai materiali più pregiati, come il legno, le pelli, la pietra e il metallo, e rappresentando il "Made and Manufactured in Italy" in tutto il mondo. Un concetto ricco di *heritage* che tanto affascina con l'aggiunta di quel tocco speciale fra passione e stile. Sinonimi in questo caso di amore per il bello e per il buon lavoro, fatto di qualità e di creazioni durevoli, senza tempo.

## L'Arte di plasmare *The art of shaping*

*In the beginning was this verb. A historic, ancestral, founding gesture. The skilled and patient hands of craftsmen shape the wood in the Giorgetti factories since its foundation in Meda, in the heart of Brianza, in 1898. Nowadays Giorgetti produces collections of seats, tables, bookcases, beds and furnishing accessories designed by important architects, some of which collaborations were born in the late 80's and that allowed to create functional, contemporary, unique and atypical products, that are able to reconcile the highest cabinetmaking with the use of sophisticated production technologies.*

*Creativity and design characterize Giorgetti furniture, giving the shape to the most precious materials, such as wood, leather, stone and metal, and representing the "Made and Manufactured in Italy" all over the world. A concept rich in heritage that fascinates with the special touch of passion and style. Synonyms in this case of love for beauty and for the good work, made of quality and timeless creations.*

# INDEX

## RE-EDITIONS

10 50250.  
12 DRY.

## SEDIE E POLTRONCINE CHAIRS AND SMALL ARMCHAIRS

18 ADAM.  
20 ALA.  
22 ALEXA.  
24 ALINA.  
26 ALL AROUND.  
30 ARABELLA.  
34 AURA.  
38 BARON.  
40 BICOLETTE  
42 CADDY.  
44 CLIP.  
46 COZY.  
48 DENNY.  
52 DIANA.  
54 DORA.  
56 ELISA.  
58 EVA.  
60 GALET.  
62 GENIUS.  
64 GIORGINA.  
66 GRAND TOUR.  
70 HUG.  
72 IBLA.  
74 INA.  
76 JANET.  
80 LADY.  
82 MAGICA.  
86 MARGOT.  
88 MOBIUS.  
98 MOVE.  
100 MUSA.  
102 NORAH.  
104 NORMAL.  
108 ODE.  
112 OPUS.  
114 PAMINA.  
116 PROGETTI.  
134 RIPPLE.  
136 ROI.  
138 SANDY.  
140 SAPHIR.  
140 TOPAZE.  
142 SELECTUS.  
144 SELENE.  
146 SINBAD.  
148 SPRING.  
152 SPRINGER  
154 SWING.  
156 TEODORA.  
160 TICHE.  
162 TILT.  
164 VENUS.

## DIVANI SOFAS

168 ADAM.  
174 AGO.  
176 ATON.  
180 DHOW.  
184 DRIVE.  
188 FABULA.  
192 GALET.  
196 MARTINI.  
198 MY.  
200 SKYLINE.  
206 SOLEMYIDAE.  
210 TAMINO.  
214 URBAN.  
216 VITTORIA.

## LETTI E COMODINI BEDS AND NIGHT TABLES

222 ADAM.  
224 ALTEA.  
226 CORIUM.  
228 FRAME.  
230 HYPNOS.  
232 IRA.  
236 KAO.  
238 PEGASO.  
240 REA.  
242 ARCHIBALD.  
244 CORIUM.  
244 FRAME.  
245 MEA.  
246 MORFEO.  
247 ROMEO.  
248 SYN.

## TAVOLI SCRITTOI E TAVOLINI TABLES WRITING DESKS AND LOW TABLES

252 AGO.  
258 AMADEUS.  
262 ANTEO.  
266 BIGWIG.  
270 BLADE.  
274 DISEGUAL.  
278 ERASMO.  
282 FANG.  
290 GORDON.  
294 MEMOS.  
300 MIZAR.  
302 ALMA.  
306 ERASMO.  
310 ION.  
312 JULIET.  
314 MOGUL.  
316 SCRIPTOR.  
322 STUDIUM.  
324 TENET.  
336 TYCOON.  
340 ZENO.  
344 AGO.  
346 AMIRAL.  
347 ATHENE.  
348 ATON.  
350 BLEND.  
352 DUAL.  
353 EOS.  
354 FIT.  
358 GALET.  
362 GRAND TOUR.  
364 LING.  
366 MAGICA.  
367 OTI.  
368 ROMEO.  
370 ROUND.  
371 SCALENO.  
372 SKYLINE.

## MOBILI E CASSETTONI SIDEBOARDS AND CHESTS OF DRAWERS

376 AEI.  
382 ALFRED.  
386 AMIRAL.  
390 BULL.  
392 CHARLOTTE.  
396 CLAIR DE LUNE.  
398 CORIUM.  
402 DIA.  
404 EON.  
406 EON BUFFET.  
408 FRAME.  
412 HOST.  
416 HOUDINI.  
424 INO.  
428 KIRI.  
432 LIA.  
434 MOORE.  
440 MYO.  
442 NARCISSE.  
444 NEA.  
446 NYN.  
448 ORIGAMI.  
452 ORO.  
456 OSCAR.  
458 RIFT.  
460 SKYLINE.  
464 THE CABINET OF  
MEMORIES.  
470 TOO.  
472 TOWN.  
480 VENUS.  
482 YANG.

## SISTEMI SYSTEMS

486 DOMUS.  
492 MYIABI.  
498 OLI  
502 REIWA.

## OPEN-AIR

512 GEA. CHAIR  
514 GEA. SMALL ARMCHAIR  
518 LOOP. CHAIR  
520 APSARA. SOFA  
530 GEA. SOFA  
534 GEA. BEACH LOUNGER  
536 BREAK. TABLE  
538 GEA. TABLE  
542 GEA. COFFEE TABLE  
544 GEA. PARASOL  
546 GEA. LAMP  
548 GEA. TRAY  
550 GEA. CANDLE-HOLDER

RE-EDITIONS

50250<sup>10</sup>.DRY<sup>12</sup>

RE-EDITION

---

# 50250

---

ADRIANO E PAOLO SUMAN 1985/2018



RE-EDITION

---

# DRY

---

MASSIMO MOROZZI 1987/2018





DRY



14  
15

---

SEDIE E POLTRONCINE  
CHAIRS AND SMALL ARMCHAIRS

---

ADAM<sup>18</sup>.ALA<sup>20</sup>.ALEXA<sup>22</sup>.ALINA<sup>24</sup>.  
ALLAROUND<sup>26</sup>.ARABELLA<sup>30</sup>.  
AURA<sup>34</sup>.BARON<sup>38</sup>.BICOLETTE<sup>40</sup>.  
CADDY<sup>42</sup>.CLIP<sup>44</sup>.COZY<sup>46</sup>.DENNY<sup>48</sup>.  
DIANA<sup>52</sup>.DORA<sup>54</sup>.ELISA<sup>56</sup>.EVA<sup>58</sup>.  
GALET<sup>60</sup>.GENIUS<sup>62</sup>.GIORGINA<sup>64</sup>.  
GRANDTOUR<sup>66</sup>.HUG<sup>70</sup>.IBLA<sup>72</sup>.INA<sup>74</sup>.  
JANET<sup>76</sup>.LADY<sup>80</sup>.MAGICA<sup>82</sup>.MARGOT<sup>86</sup>.  
MOBIUS<sup>88</sup>.MOVE<sup>98</sup>.MUSA<sup>100</sup>.NORAH<sup>102</sup>.  
NORMAL<sup>104</sup>.ODE<sup>108</sup>.OPUS<sup>112</sup>.PAMINA<sup>114</sup>.  
PROGETTI<sup>116</sup>.RIPPLE<sup>134</sup>.ROI<sup>136</sup>.SANDY<sup>138</sup>.  
SAPHIRTOPAZE<sup>140</sup>.SELECTUS<sup>142</sup>.  
SELENE<sup>144</sup>.SINBAD<sup>146</sup>.SPRING<sup>148</sup>.  
SPRINGER<sup>152</sup>.SWING<sup>154</sup>.TEODORA<sup>156</sup>.  
TICHE<sup>160</sup>.TILT<sup>162</sup>.VENUS<sup>164</sup>.

---

# ADAM

---

CARLO COLOMBO 2018



---

# ALA

---

UMBERTO ASNAGO 2017



15 > technical



---

20  
21

---

---

# ALEXA

---

UMBERTO ASNAGO 2018



---

# ALINA

---

ANTONELLO MOSCA 2015



---

# ALL AROUND

---

LUDOVICA + ROBERTO PALOMBA 2018







# ARABELLA

CARLO GIORGETTI E MASSIMO SCOLARI 2010





nuovo modo di sedersi: sorprendente varietà di posizioni  
new way of sitting: amazing range of positions



cuscinetto da usare come bracciolo  
cushion to be used as an arm



---

# AURA

---

UMBERTO ASNAGO 2014/2015





---

# BARON

---

ROBERTO LAZZERONI 2017



22 > technical



---

38

39

---

---

# BICOLETTE

---

LUDOVICA + ROBERTO PALOMBA 2020 LUDOVICA 2020



---

# CADDY

---

CARLO COLOMBO 2015



---

42  
43

---

---

# CLIP

---

M2ATELIER 2018





---

# COZY

---

UMBERTO ASNAGO 2015



# DENNY

LAURA SILVESTRINI 2011



27 > technical





---

# DIANA

---

CARLO COLOMBO 2013



---

# DORA

---

MASSIMO SCOLARI 2007/2009



29 > technical



---

54

---

55

---

---

# ELISA

---

CARLO COLOMBO 2015



---

# EVA

---

CARLO COLOMBO 2014



---

# GALET

---

LUDOVICA + ROBERTO PALOMBA 2017





---

# GENIUS

---

ROBERTO LAZZERONI 2014



---

# GIORGINA

---

ANTONELLO MOSCA 1992



---

# GRAND TOUR

---

PAOLO SUMAN 2018





---

# HUG

---

ROSSELLA PUGLIATTI 2013



---

# IBLA

---

ROBERTO LAZZERONI 2016



37 > technical



---

72  
73

---

---

INA

---

CHI WING LO 2000/2012



---

74  
75

---

---

# JANET

---

UMBERTO ASNAGO 2020







---

# LADY

---

UMBERTO ASNAGO 2015



# MAGICA

TOSHIYUKI KITA 2013



41 > technical



MAGICA



84

85

# MARGOT

ANTONELLO MOSCA 2008/2009



86

87

# MOBIUS

UMBERTO ASNAGO 2011/2016











MOBIUS



---

# MOVE

---

ROSSELLA PUGLIATTI 2014



# MUSA

ANTONELLO MOSCA 2008



---

# NORAH

---

M2ATELIER 2015



---

102

---

103

---

# NORMAL

---

MASSIMO SCOLARI 2003/2006



50 > technical



104  
105

NORMAL



106  
107

---

# ODE

---

CHI WING LO 2012/2018



51 > technical



---

108

109

---



ODE



110  
111

---

# OPUS

---

CARLO COLOMBO 2019



---

# PAMINA

---

ROBERTO LAZZERONI 2019



# PROGETTI

CENTRO RICERCHE GIORGETTI 1987/2009









PROGETTI



122  
123





# PROGETTI BLOSSOM

CENTRO RICERCHE GIORGETTI 2009

originale cucitura con inserto in pelle  
sulla parte interna dello schienale  
original stitched covering with a leather insert  
on the inside of the backrest

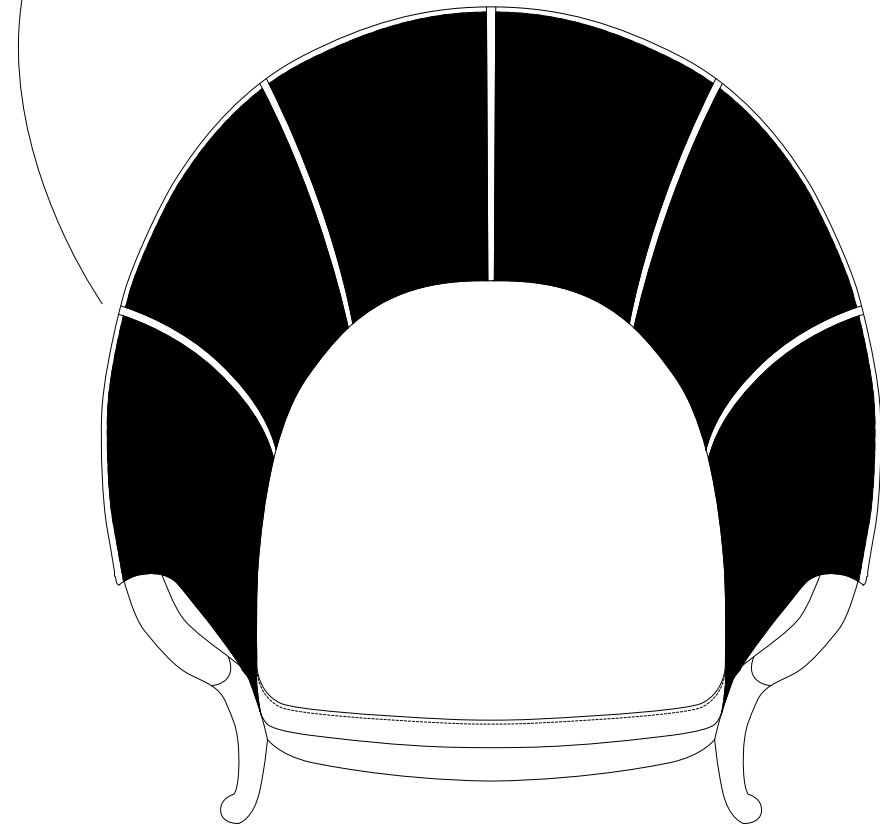

# PROGETTI FASHION

CENTRO RICERCHE GIORGETTI 2017





# PROGETTI SENSE

CENTRO RICERCHE GIORGETTI 2017



---

# RIPPLE

---

LUDOVICA + ROBERTO PALOMBA 2017



---

# ROI

---

CHI WING LO 2008



---

# SANDY

---

UMBERTO ASNAGO 2019



62 > technical



# SAPHIR TOPAZE

ANTONELLO MOSCA 2010



140  
141



# SELECTUS

LÉON KRIER 2004



---

# SELENE

---

ROBERTO LAZZERONI 2015



65 > technical



---

144

145

---

---

# SINBAD

---

ROBERTO LAZZERONI 2018



# SPRING

MASSIMO SCOLARI 1992



148  
149



SPRING

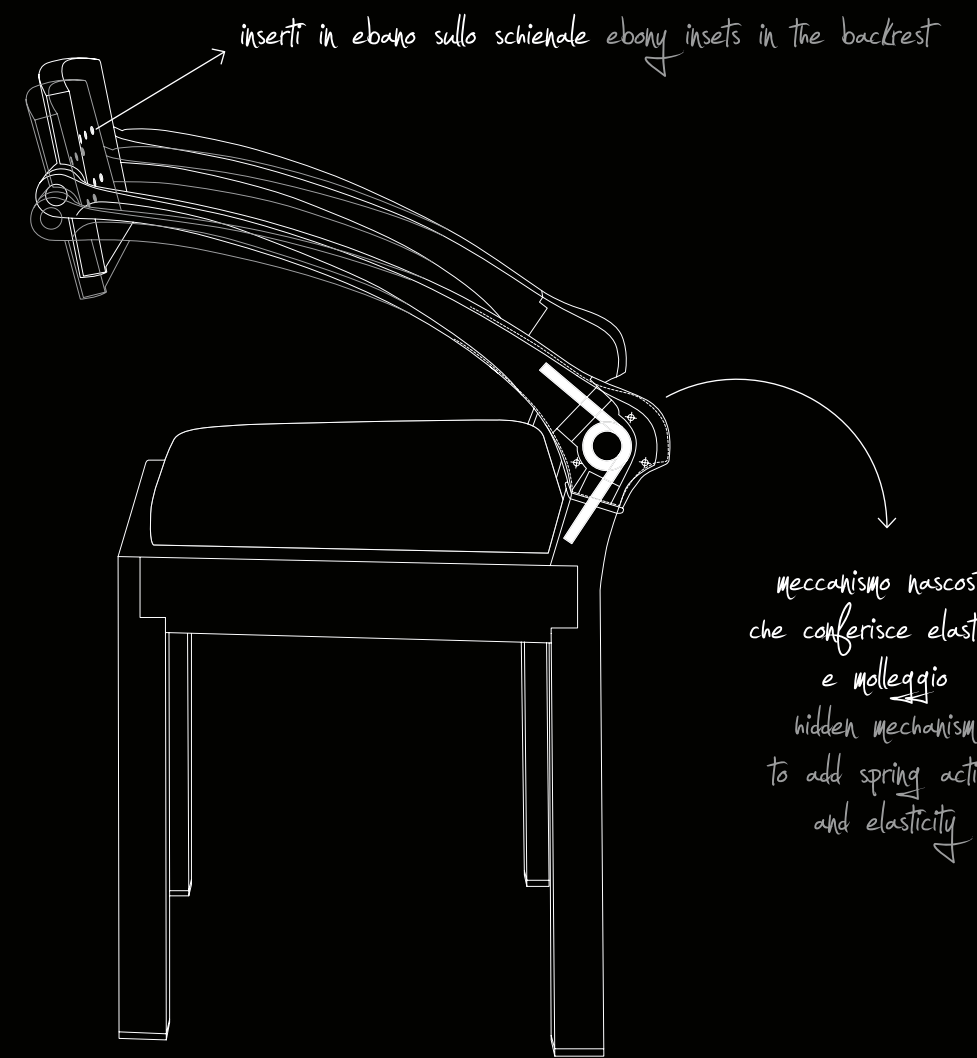

---

# SPRINGER

---

MASSIMO SCOLARI 2019



---

# SWING

---

CARLO COLOMBO 2015



---

# TEODORA

---

MASSIMO SCOLARI 2009







leva per regolare l'altezza e basculante per ottenere la posizione corretta del corpo  
lever to adjust the height and tilt to favour a correct body position

---

# TICHE

---

CARLO COLOMBO 2014



71 > technical



---

160  
161

---

---

# TILT

---

M2ATELIER 2015



---

# VENUS

---

ROBERTO LAZZERONI 2014



---

DIVANI  
SOFAS

---

ADAM<sup>168</sup>.AGO<sup>174</sup>.ATON<sup>176</sup>.DHOW<sup>180</sup>.  
DRIVE<sup>184</sup>.FABULA<sup>188</sup>.GALET<sup>192</sup>.  
MARTINI<sup>196</sup>.MY<sup>198</sup>.SKYLINE<sup>200</sup>.  
SOLEMYIDAE<sup>206</sup>.TAMINO<sup>210</sup>.  
URBAN<sup>214</sup>.VITTORIA<sup>216</sup>.

---

# ADAM

---

CARLO COLOMBO 2018



ADAM



170  
171





---

# AGO

---

CARLO COLOMBO 2014



---

174

---

175

---

---

# ATON

---

CARLO COLOMBO 2014





ATON

178  
179

# DHOW

ANDREI MUNTEANU 2011



180  
181

DHOW



182  
183

# DRIVE

CARLO COLOMBO 2016



184  
185



---

# FABULA

---

UMBERTO ASNAGO 2012/2014



---

188  
189



FABULA



190  
191

---

# GALET

---

LUDOVICA + ROBERTO PALOMBA 2018



---

192  
193

---

GALET



194  
195



---

# MARTINI

---

ROSSELLA PUGLIATTI 2015



---

196  
197

---

MY

---

ROSSELLA PUGLIATTI 2014

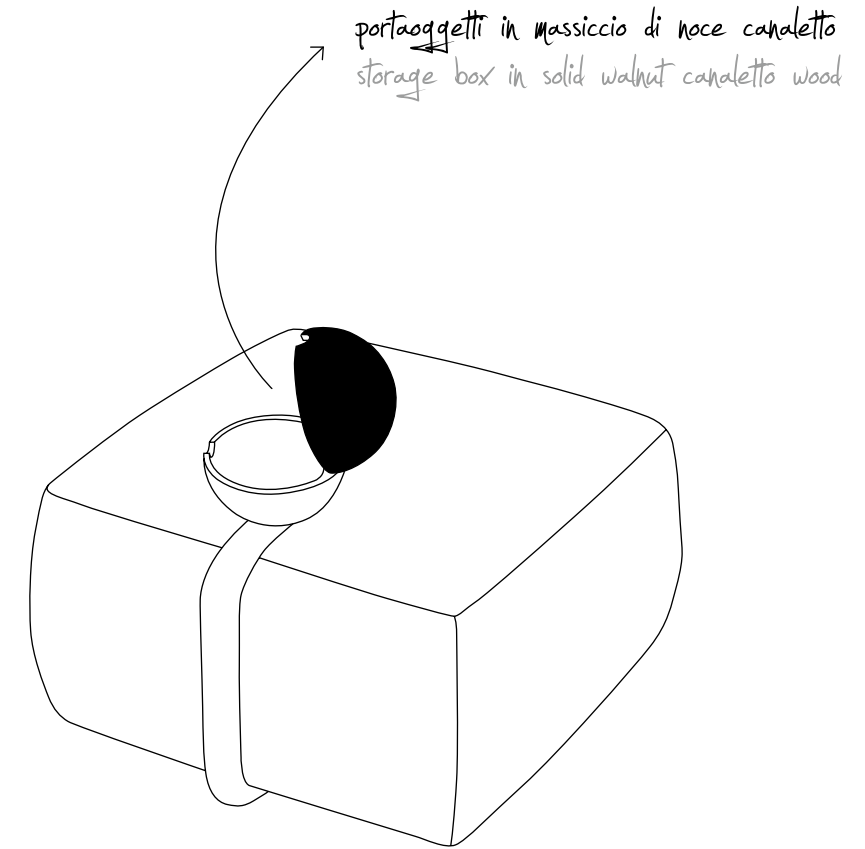

---

# SKYLINE

---

CARLO COLOMBO 2019



SKYLINE



202  
203

SKYLINE



204  
205



---

# SOLEMYIDAE

---

ROSSELLA PUGLIATTI 2013



---

206  
207



---

# TAMINO

---

ROBERTO LAZZERONI 2019



TAMINO



---

# URBAN

---

CARLO COLOMBO 2015



---

214  
215

# VITTORIA

CARLO COLOMBO 2013



216  
217

VITTORIA



218  
219



---

LETTI E COMODINI  
BEDS AND NIGHT-TABLES

---

ADAM<sup>222</sup>.ALTEA<sup>224</sup>.CORIUM<sup>226</sup>.  
FRAME<sup>228</sup>.HYPNOS<sup>230</sup>.IRA<sup>232</sup>.  
KAO<sup>236</sup>.PEGASO<sup>238</sup>.REA<sup>240</sup>.  
ARCHIBALD<sup>242</sup>.CORIUM<sup>243</sup>.  
FRAME<sup>244</sup>.MEA<sup>245</sup>.MORFEO<sup>246</sup>.  
ROMEO<sup>247</sup>.SYN<sup>248</sup>.



---

# ADAM

---

CARLO COLOMBO 2020



112 > technical



---

222  
223

---

---

# ALTEA

---

CARLO COLOMBO 2013



114 > technical



---

224  
225

---

# CORIUM

UMBERTO ASNAGO 2012



---

# FRAME

---

CARLO COLOMBO 2017



---

# HYPNOS

---

UMBERTO ASNAGO 2017



117 > technical



---

230  
231

---

# IRA

---

CHI WING LO 2012



---

232  
233

---



---

**KAO**

---

CHI WING LO 2009



119 > technical



---

236  
237

---



---

# PEGASO

---

ROBERTO LAZZERONI 2018



# REA

CHI WING LO 2005



123 > technical



240  
241

# ARCHIBALD

ROBERTO LAZZERONI 2014



124 > technical

# CORIUM

UMBERTO ASNAGO 2012



125 > technical

---

# FRAME

---

CARLO COLOMBO 2017



---

# MEA

---

CHI WING LO 2009



---

# MORFEO

---

CARLO COLOMBO 2013



---

# ROMEO

---

ROBERTO LAZZERONI 2018



---

SYN

---

CHI WING LO 2012



130> technical



---

248  
249

---

TAVOLI SCRITTOI E TAVOLINI  
TABLES WRITING DESKS AND LOW TABLES

AGO.<sup>252</sup> AMADEUS.<sup>258</sup> ANTEO.<sup>262</sup>  
BIGWIG.<sup>266</sup> BLADE.<sup>270</sup> DISEGUAL.<sup>274</sup>  
ERASMO.<sup>278</sup> FANG.<sup>282</sup> GORDON.<sup>290</sup>  
MEMOS.<sup>294</sup> MIZAR.<sup>300</sup> ALMA.<sup>302</sup> ERASMO.<sup>306</sup>  
ION.<sup>310</sup> JULIET.<sup>312</sup> MOGUL.<sup>314</sup> SCRIPTOR.<sup>316</sup>  
STUDIUM.<sup>322</sup> TENET.<sup>324</sup> TYCOON.<sup>336</sup>  
ZENO.<sup>340</sup> AGO.<sup>344</sup> AMIRAL.<sup>346</sup> ATHENE.<sup>347</sup>  
ATON.<sup>348</sup> BLEND.<sup>350</sup> DUAL.<sup>352</sup> EOS.<sup>353</sup> FIT.<sup>354</sup>  
GALET.<sup>358</sup> GRANDTOUR.<sup>362</sup> LING.<sup>364</sup>  
MAGICA.<sup>366</sup> OTI.<sup>367</sup> ROMEO.<sup>368</sup> ROUND.<sup>370</sup>  
SCALENO.<sup>371</sup> SKYLINE.<sup>372</sup>

---

**AGO**

---

CARLO COLOMBO 2020



---

252

253

---





Piano in legno suddiviso in quattro parti con effetto speculare  
Wooden top divided into four parts with mirror effect

Piano in marmo formato da una lastra unica  
Marble top consisting of a single slab

Le gambe richiamano la forma dell'ago da cucito,  
la cui cruna evidenzia l'ellitticità della struttura in metallo  
The legs recall the shape of a sewing needle,  
whose eye highlights the elliptical section  
of the metal structure

Struttura in metallo arricchita dalla placcatura  
con quattro coppie di masselli di noce canaleto torniti.  
Ogni massello ha un disegno ed una lavorazione diversi dagli altri  
Metal structure enriched by the plating  
with four pairs of latned solid canaleto walnut pieces.  
Each piece is made with a different design  
and workmanship from the others of the metal structure

---

# AMADEUS

---

ROBERTO LAZZERONI 2019





ANTEO

260  
261

---

# ANTEO

---

CARLO COLOMBO 2014



---

262  
263

---



ANTEO

264

265

---

# BIG WIG

---

ROBERTO LAZZERONI 2017





BIGWIG



268  
269



---

# BLADE

---

UMBERTO ASNAGO 2017



140 > technical



---

270  
271

---

BLADE



272  
273

---

# DISEGUAL

---

UMBERTO ASNAGO 2018



141 > technical



---

274  
275

---



---

# ERASMO

---

MASSIMO SCOLARI 2010



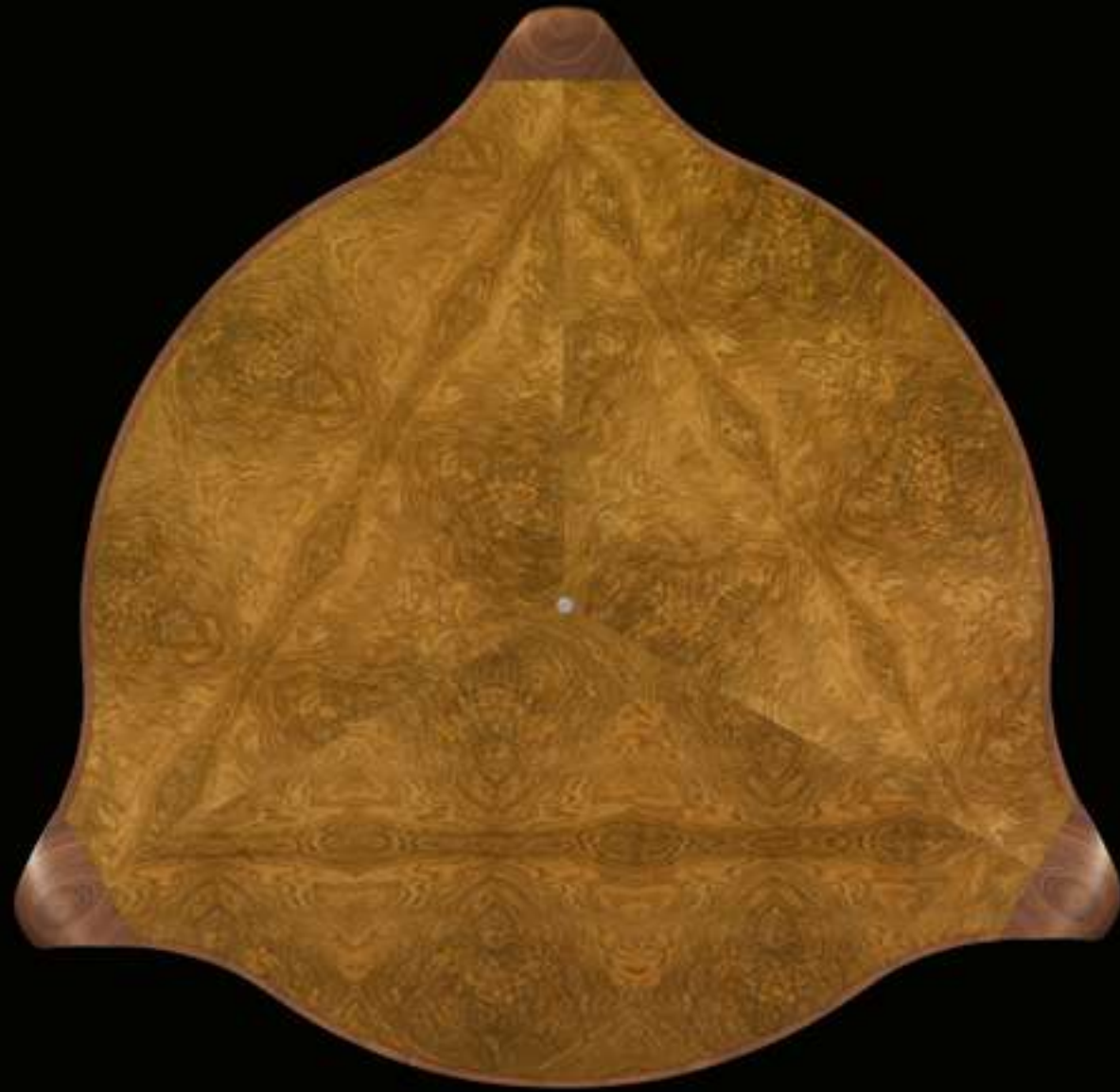

FANG  
DESIGN MWW 2013











# GORDON

ROBERTO LAZZERONI 2014



290  
291

GORDON



292  
293

---

# MEMOS

---

ROBERTO LAZZERONI 2016



149 -> technical



---

294

295

---

MEMOS



296  
297



MEMOS



298  
299

---

# MIZAR

---

ROBERTO LAZZERONI 2015



---

300  
301

---



---

# ALMA

---

PAMELA AMINE 2017



152 > technical



---

302  
303

---

ALMA



304  
305

---

# ERASMO

---

MASSIMO SCOLARI 2009



153 > technical



---

306  
307

---

ERASMO



forma a foglia del piano  
calibra le distanze tra i due lati opposti  
leaf shape of the top  
to gauge the distances between the two opposite sides

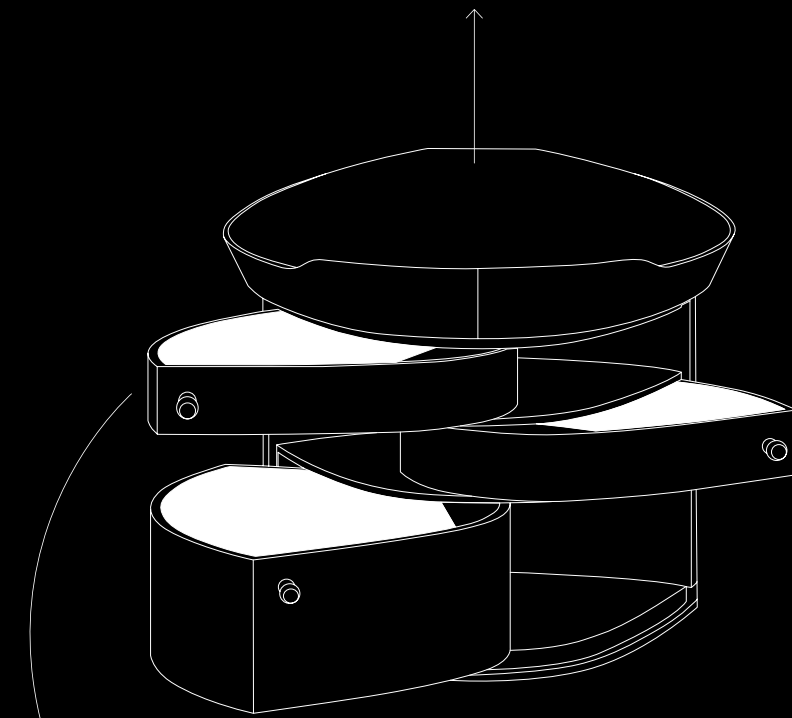

tre cassetti con sistema di apertura indipendente a 360° gradi  
three drawers with independent 360° opening system

cassetti estraibili su entrambi i lati  
extractable drawers on either sides

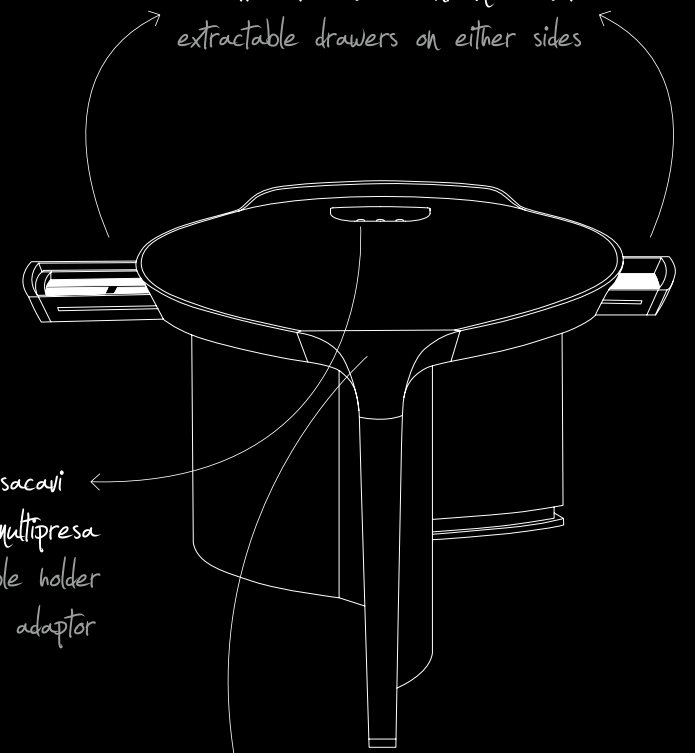

passacavi e multipresa  
cable holder and adaptor

gamba unica e raccordo in noce  
canaletto naturale  
one leg and join in walnut canaletto wood

---

# ION

---

CHI WING LO 2012



---

# JULIET

---

ROBERTO LAZZERONI 2018



156 > technical



312  
313

---

# MOGUL

---

ROBERTO LAZZERONI 2017



---

# SCRIPTOR

---

LÉON KRIER 2004/2007



158 > technical



316

317





SCRIPTOR



318  
319

SCRIPTOR

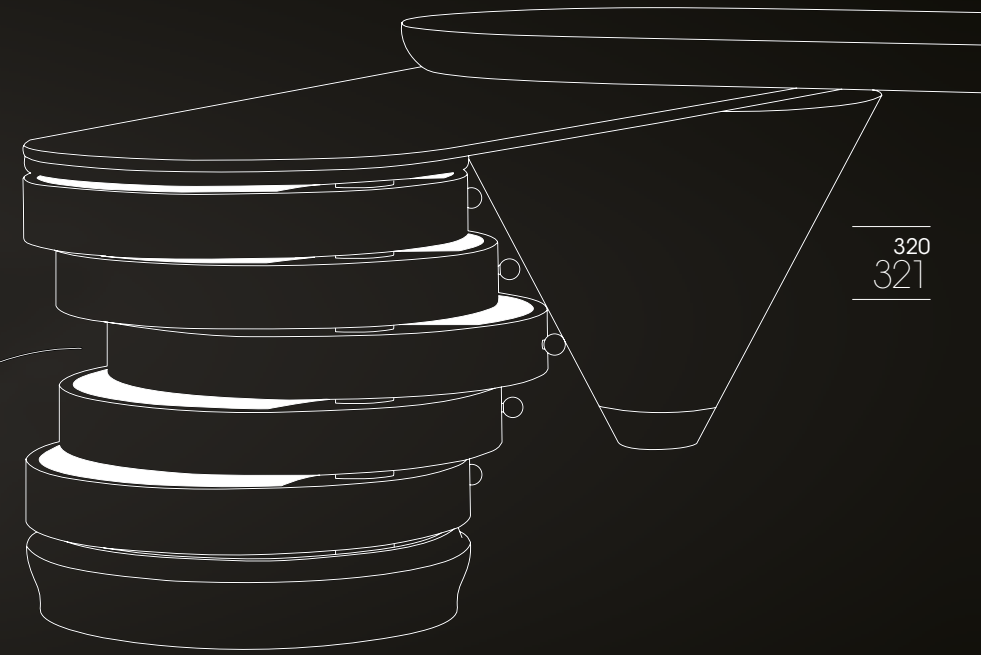

cassettiera cilindrica a 5 cassetti con sistema di apertura indipendente a 180 gradi  
cylindrical chest with 5 drawers that have independent 180° opening system

---

# STUDIUM

---

UMBERTO ASNAGO 2015



160 > technical



---

322  
323

---

---

# TENET

---

MASSIMO SCOLARI 2017/2018





TENET



326  
327



TENET



328  
329





TENET



332  
333





---

# TYCOON

---

ROBERTO LAZZERONI 2014



163 > technical



336  
337



TYCOON



338  
339

---

# ZENO

---

MASSIMO SCOLARI 1994



340  
341



ZENO

342  
343

---

AGO

---

CARLO COLOMBO 2014



---

344  
345

---

---

# AMIRAL

---

LEONARDO DAINELLI 2019



---

# ATHENE

---

ANTONELLO MOSCA 1997/2009



---

# ATON

---

CARLO COLOMBO 2014



---

348  
349



---

# BLEND

---

CARLO COLOMBO 2016



---

350  
351

---

# DUAL

---

CENTRO RICERCHE GIORGETTI 2007



175 > technical

---

# EOS

---

CHI WING LO 2003/2012



176 > technical

---

# FIT

---

GIANCARLO BOSIO E CENTRO RICERCHE GIORGETTI 2018

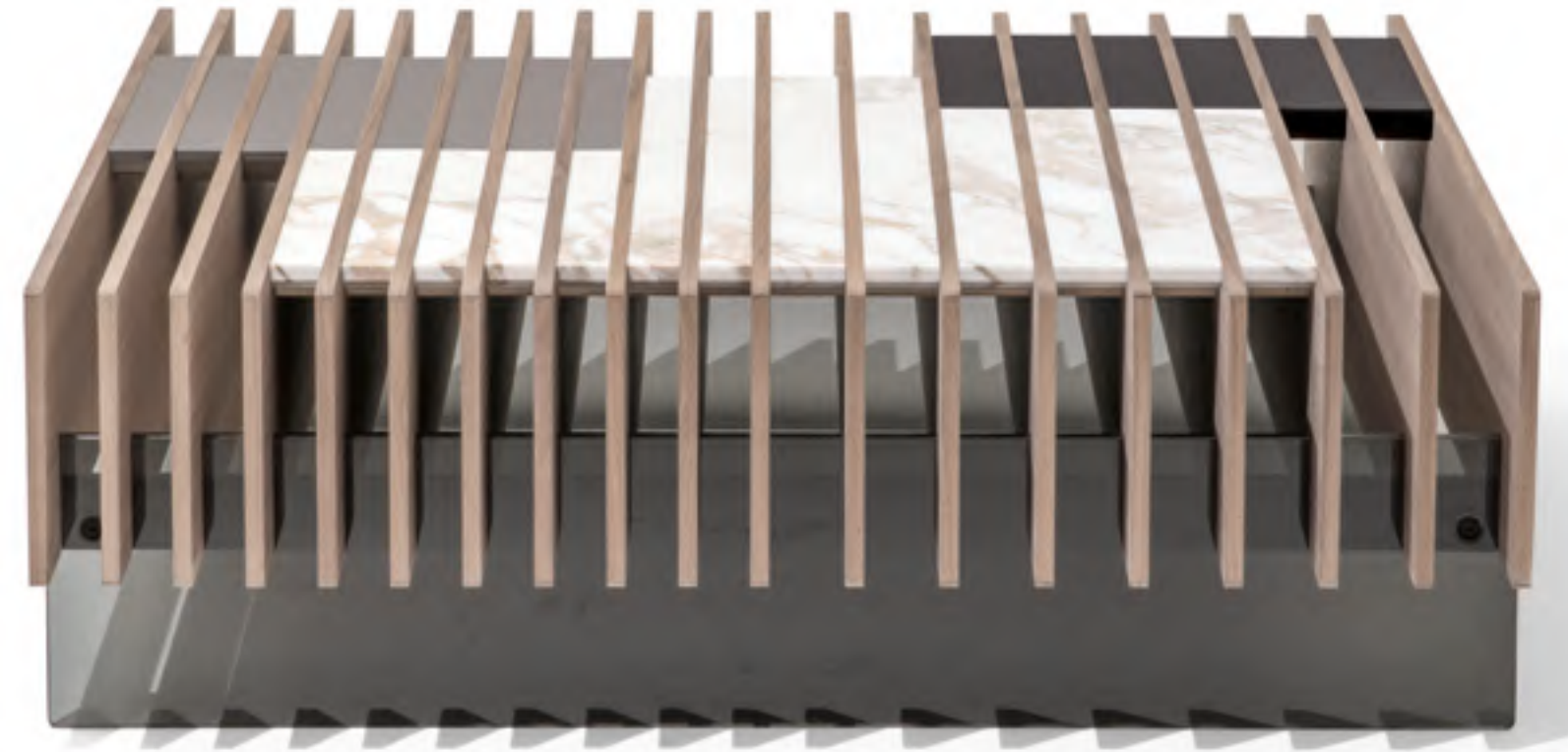

FIT



356  
357

---

# GALET

---

LUDOVICA + ROBERTO PALOMBA 2017



178 > technical



358  
359

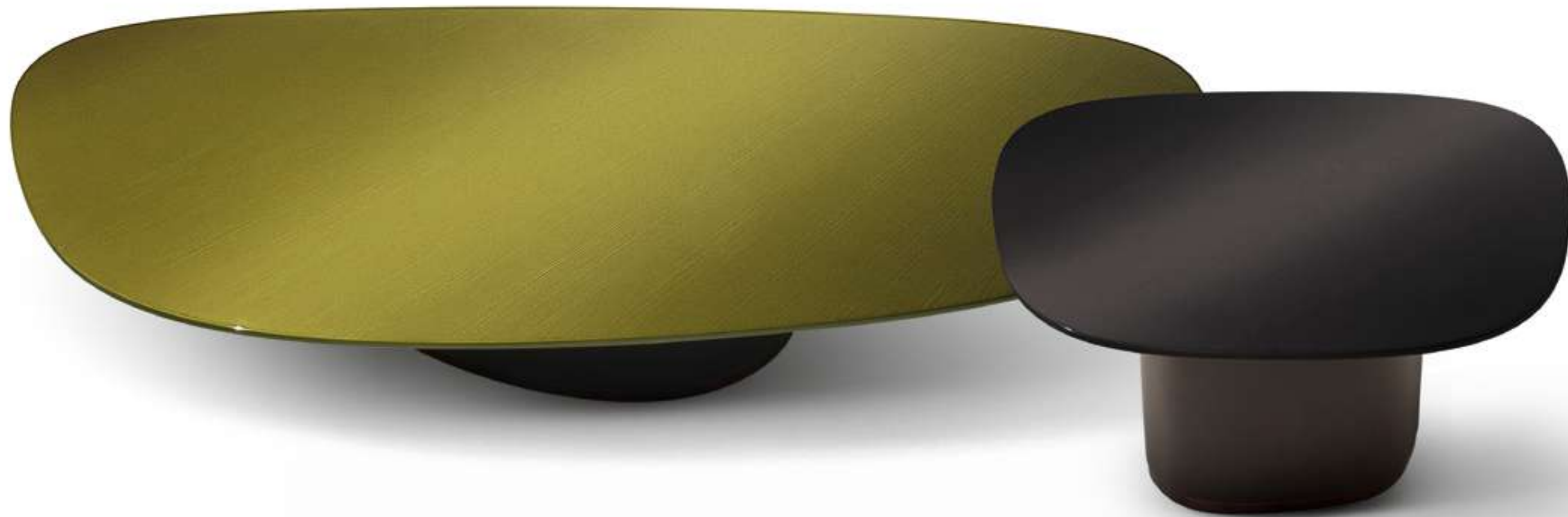

---

# GRAND TOUR

---

PAOLO SUMAN 2018



---

# LING

---

DESIGN MVW 2013



---

364  
365



---

# MAGICA

---

TOSHIYUKI KITA 2013



---

# OTI

---

CHI WING LO 2000/2009



---

# ROMEO

---

ROBERTO LAZZERONI 2018



185 > technical



---

368  
369

---

---

# ROUND

---

CARLO COLOMBO 2015



---

# SCALENO

---

GIANCARLO BOSIO & CENTRO RICERCHE GIORGETTI 2020



---

# SKYLINE

---

CARLO COLOMBO 2019



---

MOBILI E CASSETTONI  
SIDEBOARDS AND CHESTS OF DRAWERS

---

AEI<sup>376</sup>.ALFRED<sup>382</sup>.AMIRAL<sup>386</sup>.BULL<sup>390</sup>.  
CHARLOTTE<sup>392</sup>.CLAIRDELUNE<sup>396</sup>.  
CORIUM<sup>398</sup>.DIA<sup>402</sup>.EON<sup>404</sup>.EONBUFFET<sup>406</sup>.  
FRAME<sup>408</sup>.HOST<sup>412</sup>.HOUDINI<sup>416</sup>.  
INO<sup>424</sup>.KIRI<sup>428</sup>.LIA<sup>432</sup>.MOORE<sup>434</sup>.MYO<sup>440</sup>.  
NARCISSE<sup>442</sup>.NEA<sup>444</sup>.NYN<sup>446</sup>.ORIGAMI<sup>448</sup>.  
ORO<sup>452</sup>.OSCAR<sup>456</sup>.RIFT<sup>458</sup>.SKYLINE<sup>460</sup>.  
THE CABINET OF MEMORIES<sup>464</sup>.  
TOO<sup>470</sup>.TOWN<sup>472</sup>.VENUS<sup>480</sup>.YANG<sup>482</sup>.

---

# AEI

---

CHI WING LO 2011/2018



195 > technical



194 > technical



AEI



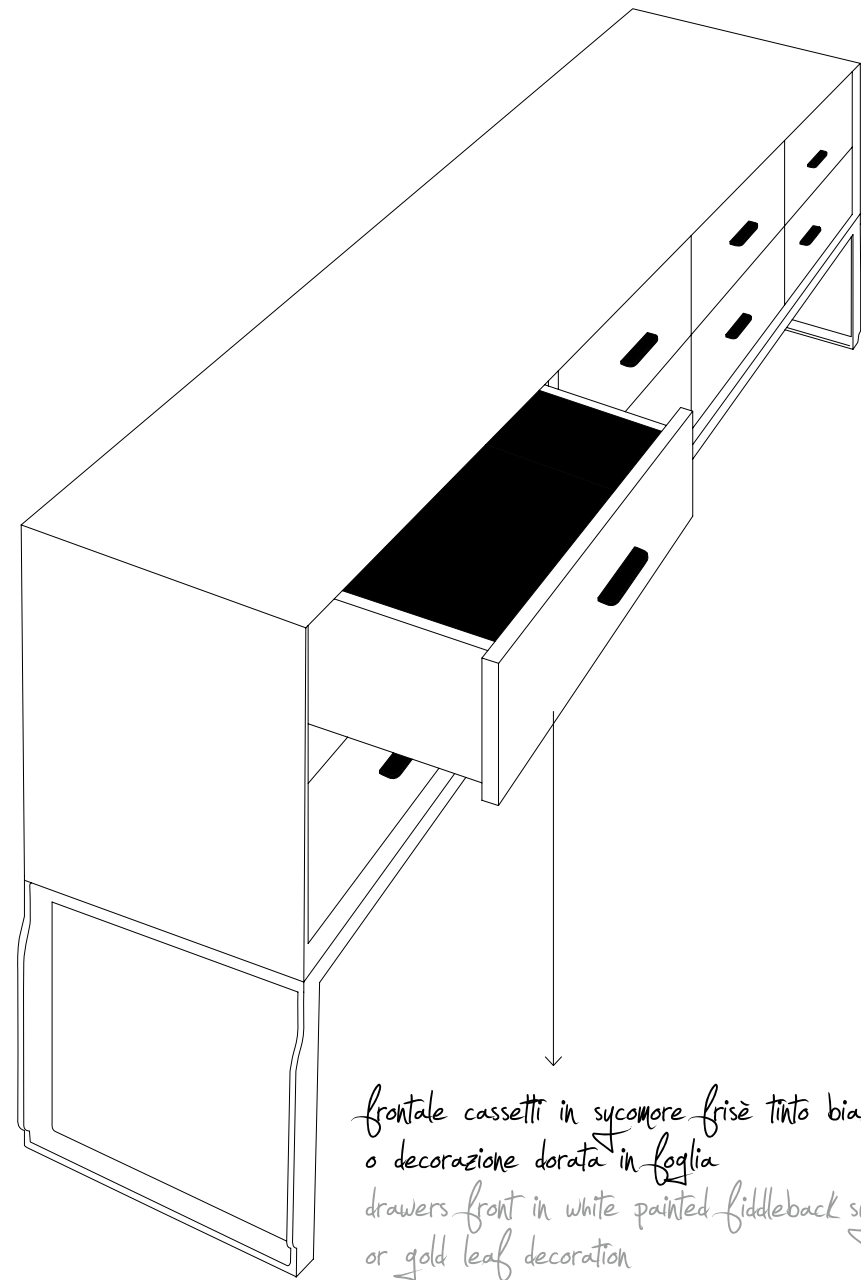

frontale cassetti in sycamore frisé tinto bianco  
 o decorazione dorata in foglia  
 drawers front in white painted fiddleback sycamore  
 or gold leaf decoration





---

# ALFRED

---

CENTRO RICERCHE GIORGETTI 2018





---

# AMIRAL

---

LEONARDO DAINELLI 2019



---

# AMIRAL

---

LEONARDO DAINELLI 2020



---

# BULL

---

ROBERTO LAZZERONI 2014



---

390  
391

---

---

# CHARLOTTE

---

CARLO COLOMBO 2018



201 > technical



---

392  
393

---

CHARLOTTE



394  
395

# CLAIR DE LUNE

DESIGN MVW 2013



203 > technical



396  
397



# CORIUM

UMBERTO ASNAGO 2013



204 > technical



398  
399



---

# DIA

---

CHI WING LO 2012



---

402  
403

---

# EON

---

CHI WING LO 1995/2012

*cassetti estraibili singolarmente grazie a distanziali in arnite*  
*independent drawer opening thanks to arnite spacers*

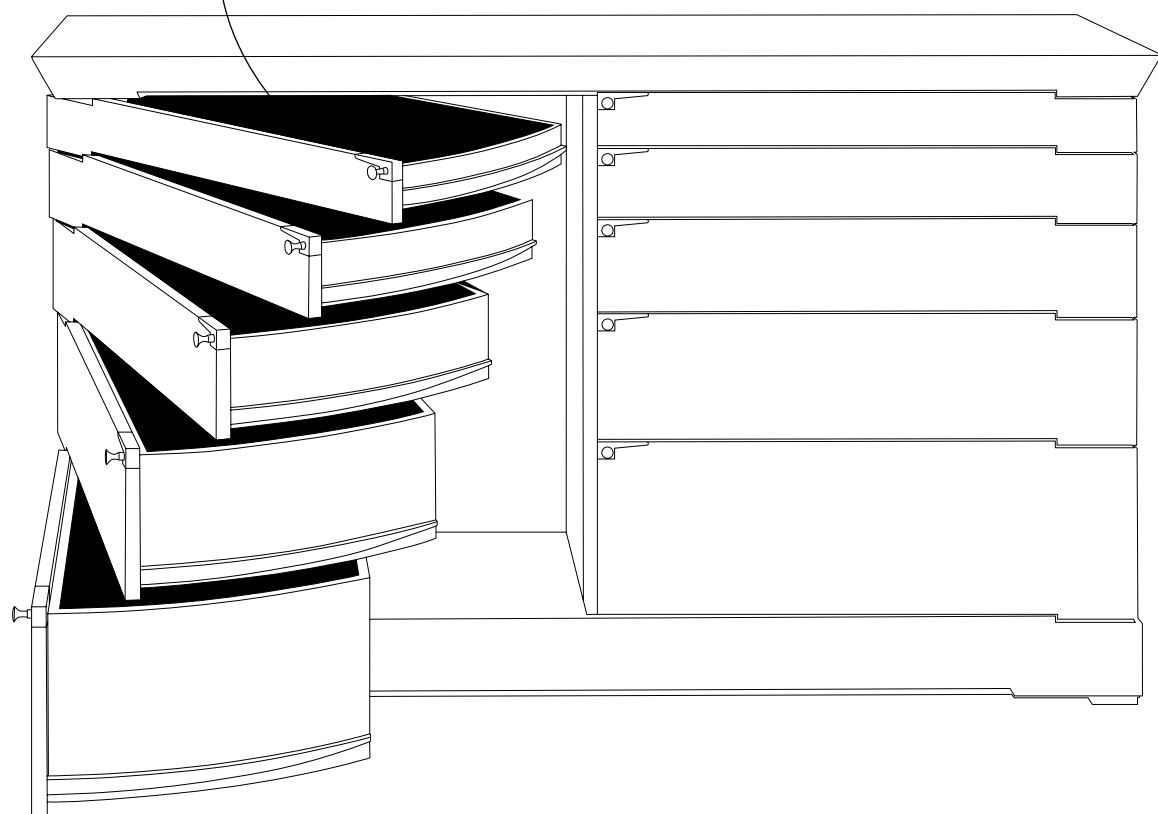

# EON BUFFET

CHI WING LO 2008



207 > technical



406  
407

---

# FRAME

---

CARLO COLOMBO 2017



208 > technical



408  
409

FRAME



209 > technical



210 > technical

410  
411

---

# HOST

---

ADAM D. TIHANY 2020







---

# HOUDINI

---

ROBERTO LAZZERONI 2021



212 > technical



416  
417



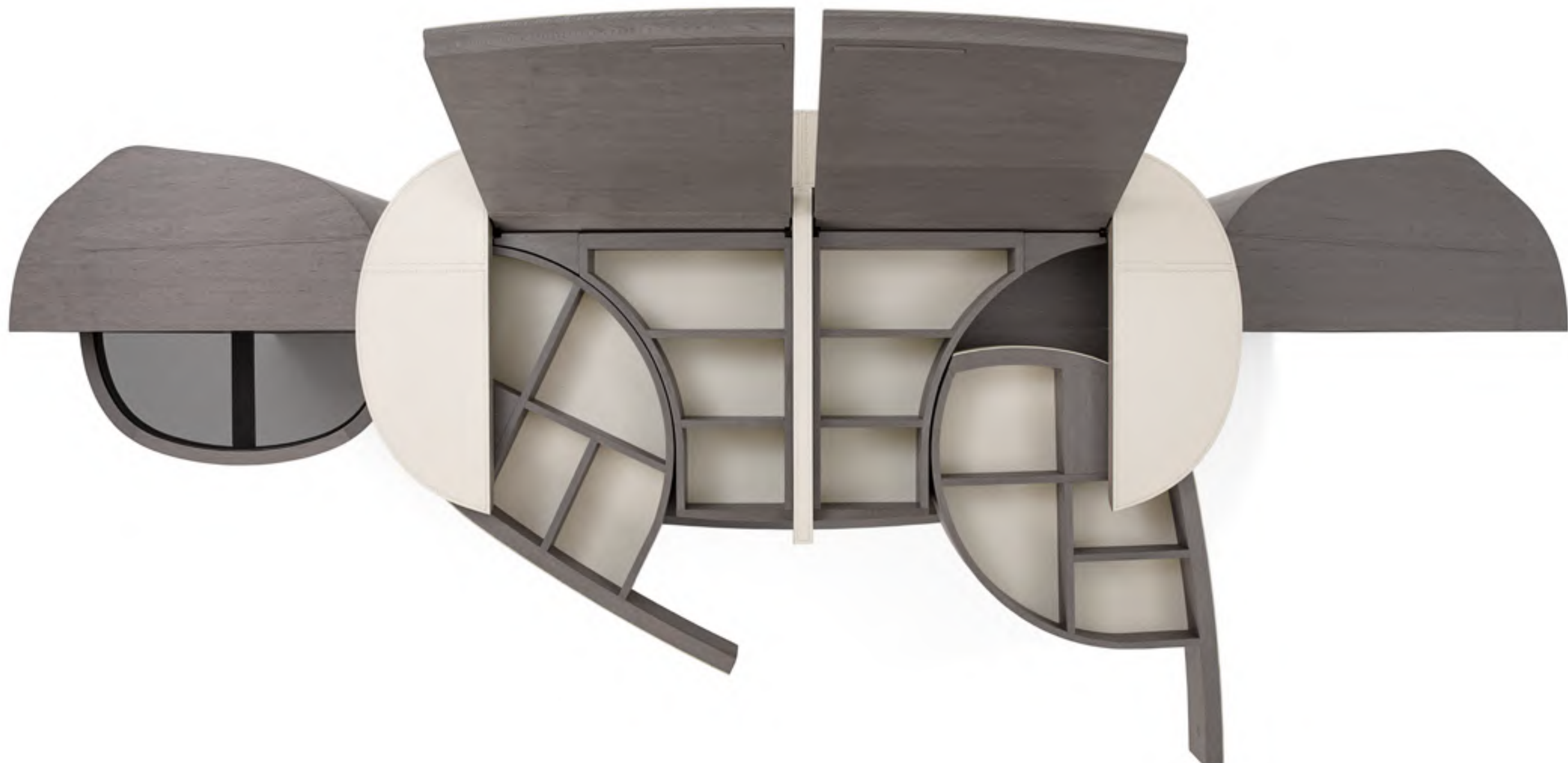



---

# INO

---

CHI WING LO 2011



424  
425



interno disponibile in  
Sycamore frisé tinto bianco  
o decorazione dorata in foglia  
internal part available in  
white painted Fiddleback Sycamore  
or gold leaf decoration

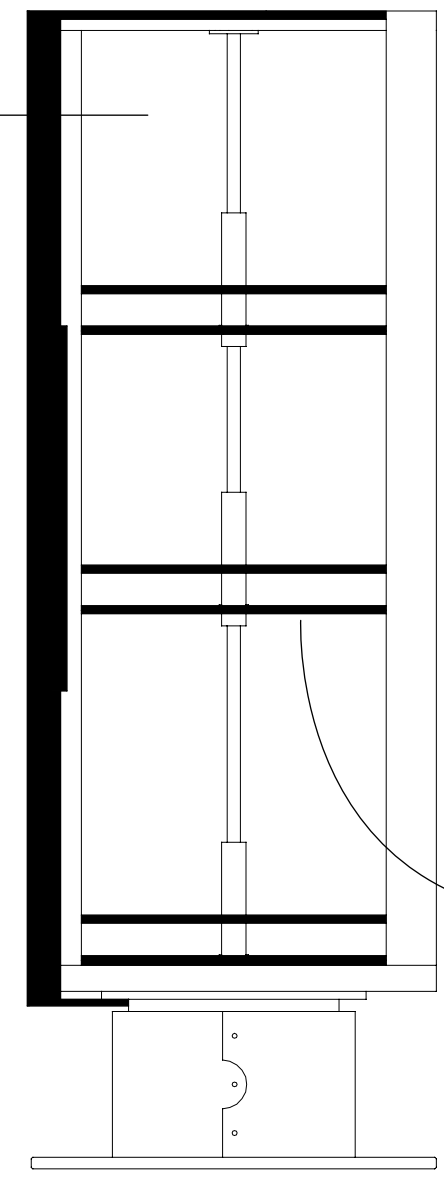

vassoi girevoli  
regolabili in altezza  
e piano in cristallo con luci led  
revolving trays  
that can be regulated in height  
with glass tops and led lights

---

# KIRI

---

SETSU & SHINOBU ITO 2020







# LIA

CHI WING LO 1995/2012

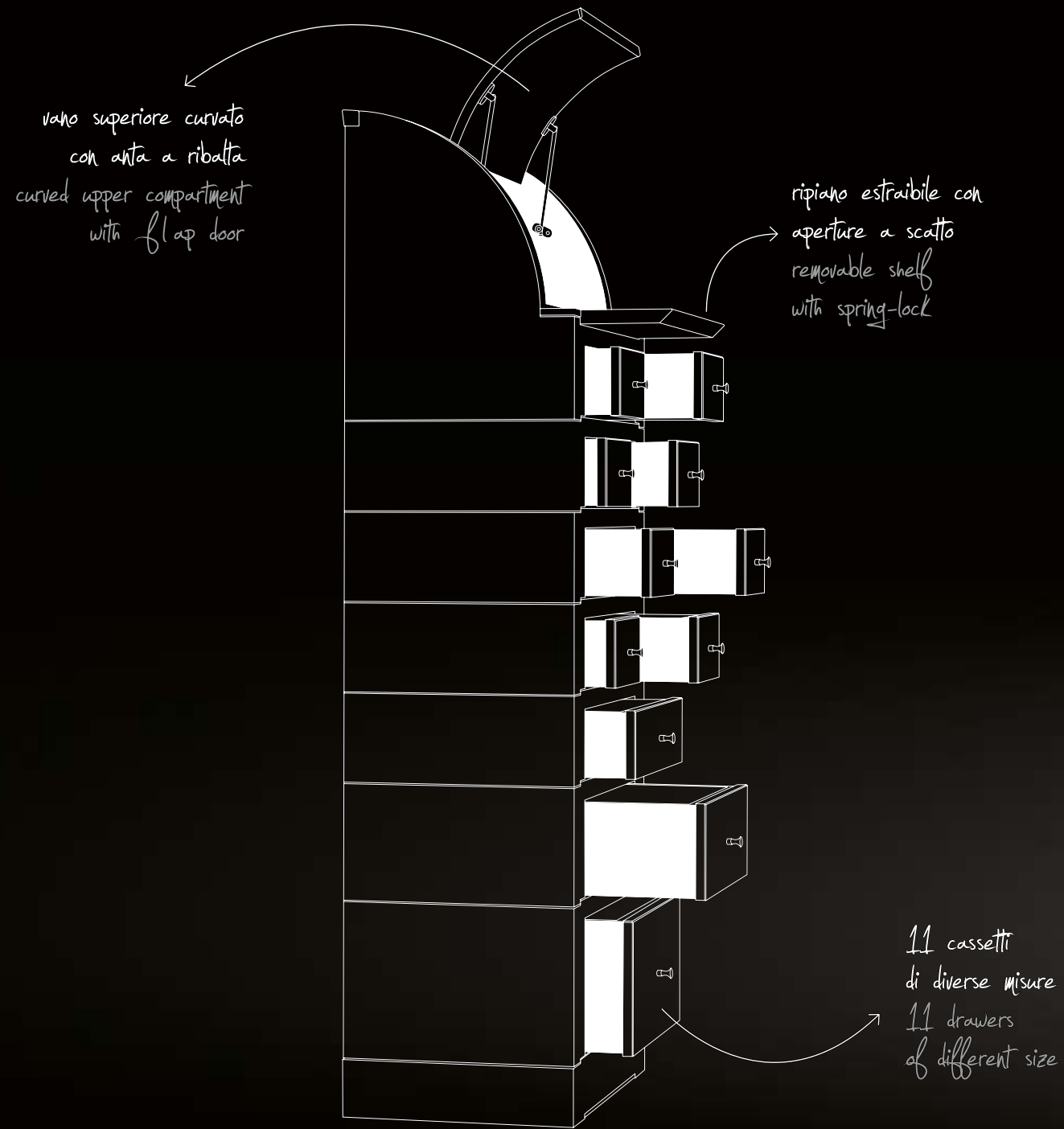

---

# MOORE

---

ROBERTO LAZZERONI 2015/2016



---

434  
435

MOORE



436  
437





# MYO

CHI WING LO 2012



221 > technical



440  
441

---

# NARCISSE

---

DESIGN MVW 2013



222 > technical



---

442  
443

---

---

# NEA

---

CHI WING LO 2010





---

# NYN

---

CHI WING LO 1995/2012

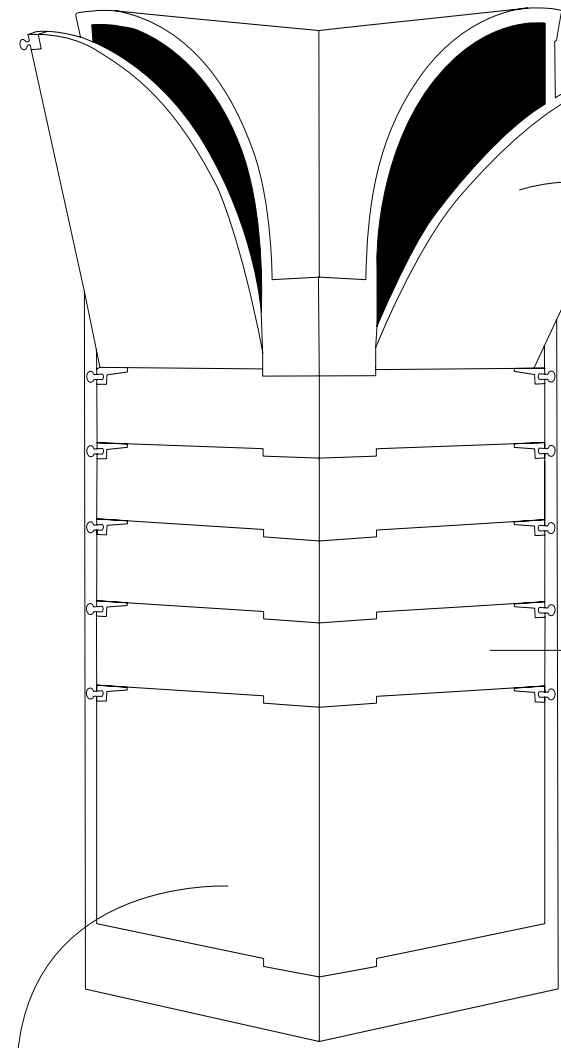

2 piani mobili  
2 flap doors

4 cassetti piccoli  
con apertura a 360°  
4 small drawers  
with a 360° swivel mechanism

1 cassetto grande con apertura a 360°  
1 large drawer with a 360° swivel mechanism



---

# ORIGAMI

---

MASSIMO CASTAGNA 2013



225 > technical



---

448  
449

---

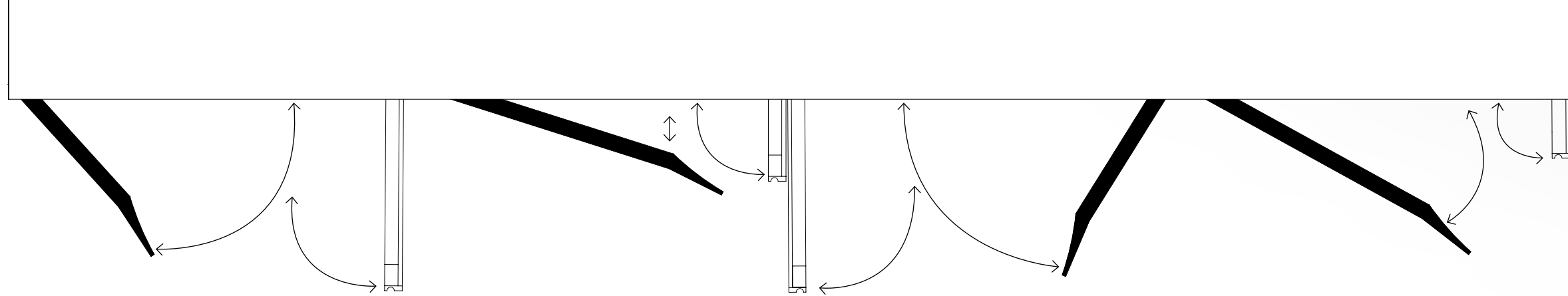

facciate con ante sovrapposte. anta esterna in eucalipto affumicato, anta interna in legno o vetro o cuoio  
front parts with overlapping doors. external door in smoked eucalyptus, internal one in wood or glass or saddle leather

# ORO

CHI WING LO 2012



1 specchio circolare regolabile nell'inclinazione, con inserto ingranditore e luce  
1 adjustable tilt round mirror, with magnifying insert and light

17 cassetti frontali di 3 differenti dimensioni  
17 frontal drawers of 3 different sizes

1 secretaire 1 hidden glove box

1 anta a contenitore  
1 storage door

3 cassetti laterali  
3 side drawers

1 calzascarpe 1 shoehorn

1 vano inferiore portascarpe 1 lower space for shoes



---

# OSCAR

---

LAURA SILVESTRINI 2011



---

# RIFT

---

GIANCARLO BOSIO E CENTRO RICERCHE GIORGETTI 2017



228 > technical

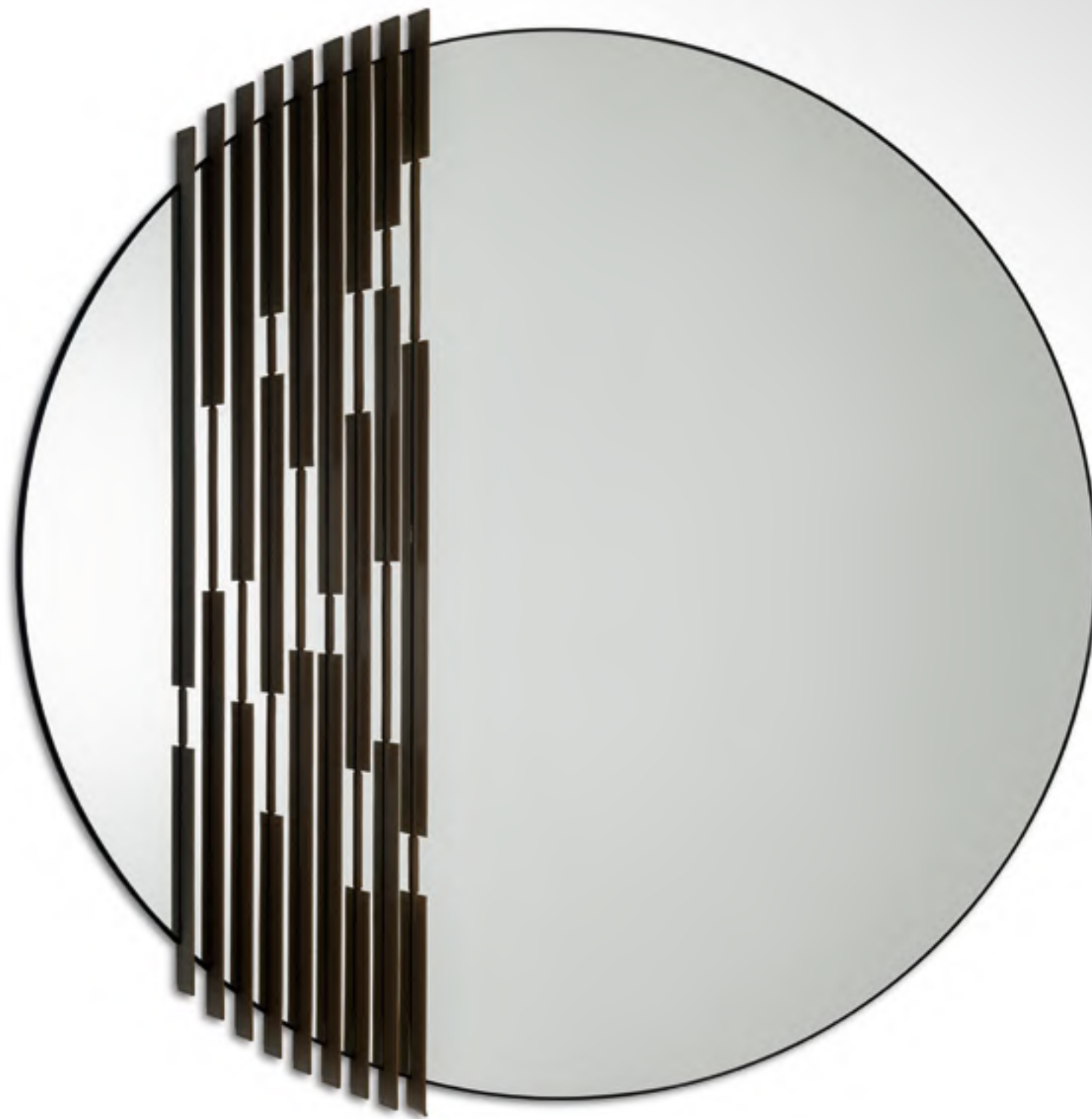

---

458

459

---

---

# SKYLINE

---

CARLO COLOMBO 2019



229 > technical



---

460  
461

---





SKYLINE



462  
463

---

# THE CABINET OF MEMORIES

---

CHI WING LO 2018



231 > technical



---

464  
465

---



THE CABINET  
OF MEMORIES

a three-dimensional album preserving dear moments in life

*Chigi* GIORGETTI  
designed by OFF-ON/OFF 2018 120th



466  
467



---

# TOO

---

UMBERTO ASNAGO 2018



---

470  
471

---

---

# TOWN

---

CARLO COLOMBO 2014/2018



472  
473







TOWN



478  
479

---

# VENUS

---

ROBERTO LAZZERONI 2014



---

# YANG

---

DESIGN MVW 2013



240 > technical



SISTEMI  
SYSTEMS

DOMUS<sup>486</sup>.MIYABI<sup>492</sup>.OLI<sup>498</sup>.REIWA<sup>502</sup>.

---

# DOMUS

---

CARLO COLOMBO E CENTRO RICERCHE GIORGETTI 2020







DOMUS



490  
491

---

# MIYABI

---

CENTRO RICERCHE GIORGETTI 2020









---

# OLI

---

CHI WING LO 1995/2016





---

# REIWA

---

CENTRO RICERCHE GIORGETTI 2019



502  
503

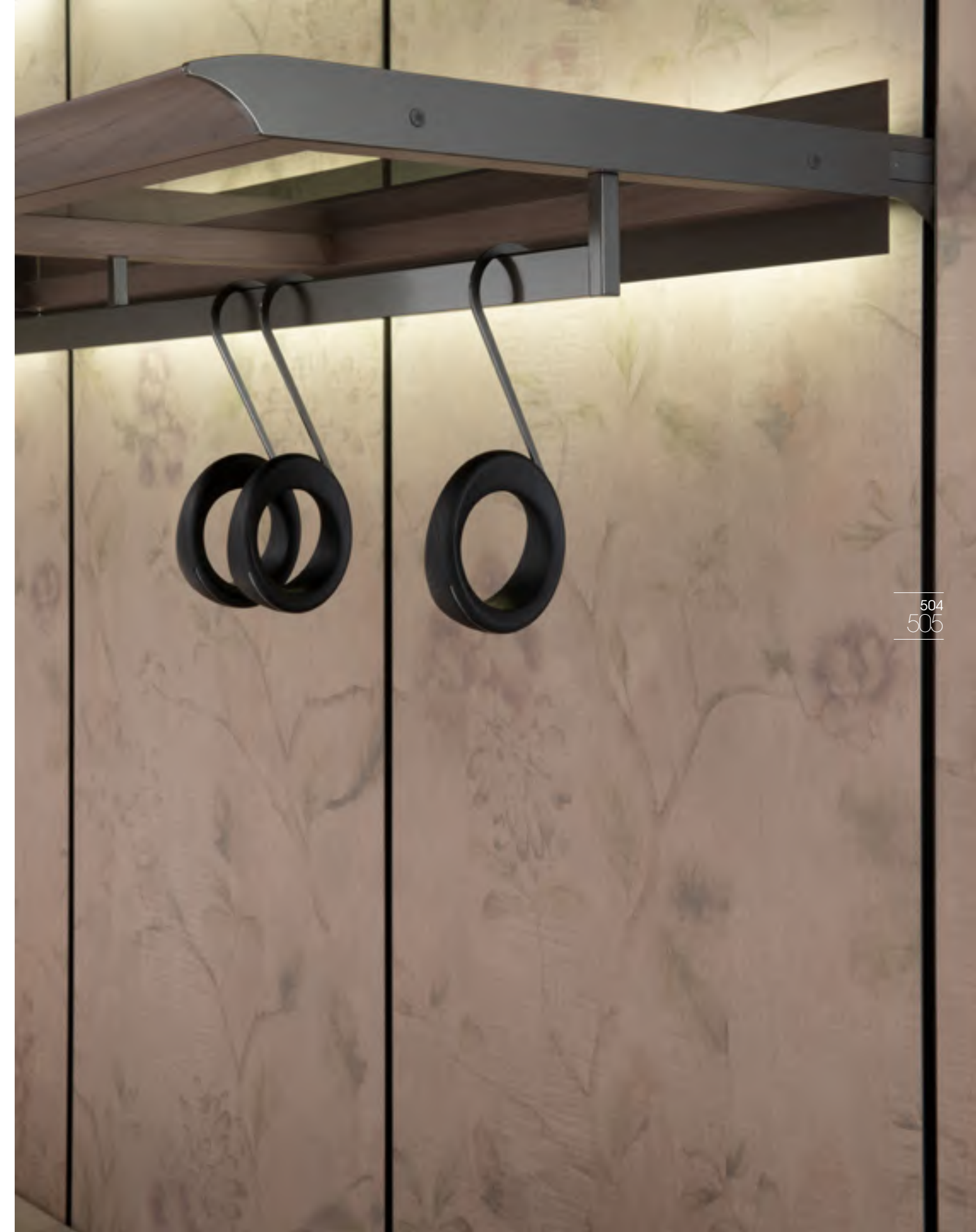







---

OPEN-AIR

---

GEACHAIR.<sup>512</sup> GEASMALL  
ARMCHAIR.<sup>514</sup> LOOP.<sup>518</sup>  
APSARA.<sup>520</sup> GEASOFA.<sup>530</sup>  
GEABEACHLOUNGER.<sup>534</sup>  
BREAK.<sup>536</sup> GEATABLE.<sup>538</sup>  
GEACOFFEETABLE.<sup>542</sup>  
GEAPARASOL.<sup>544</sup> GEALAMP.<sup>546</sup>  
GEATRAY.<sup>548</sup> GEACANDLE  
HOLDER.<sup>550</sup>

OPEN-AIR

# GEA

CHI WING LO 2017



512

513

OPEN-AIR

---

# GEA

---

CHI WING LO 2017





OPEN-AIR

---

# LOOP

---

LUDOVICA+ROBERTO PALOMBA 2019



518

519

OPEN-AIR

---

# APSARA

---

LUDOVICA + ROBERTO PALOMBA 2017





APSARA



522

523





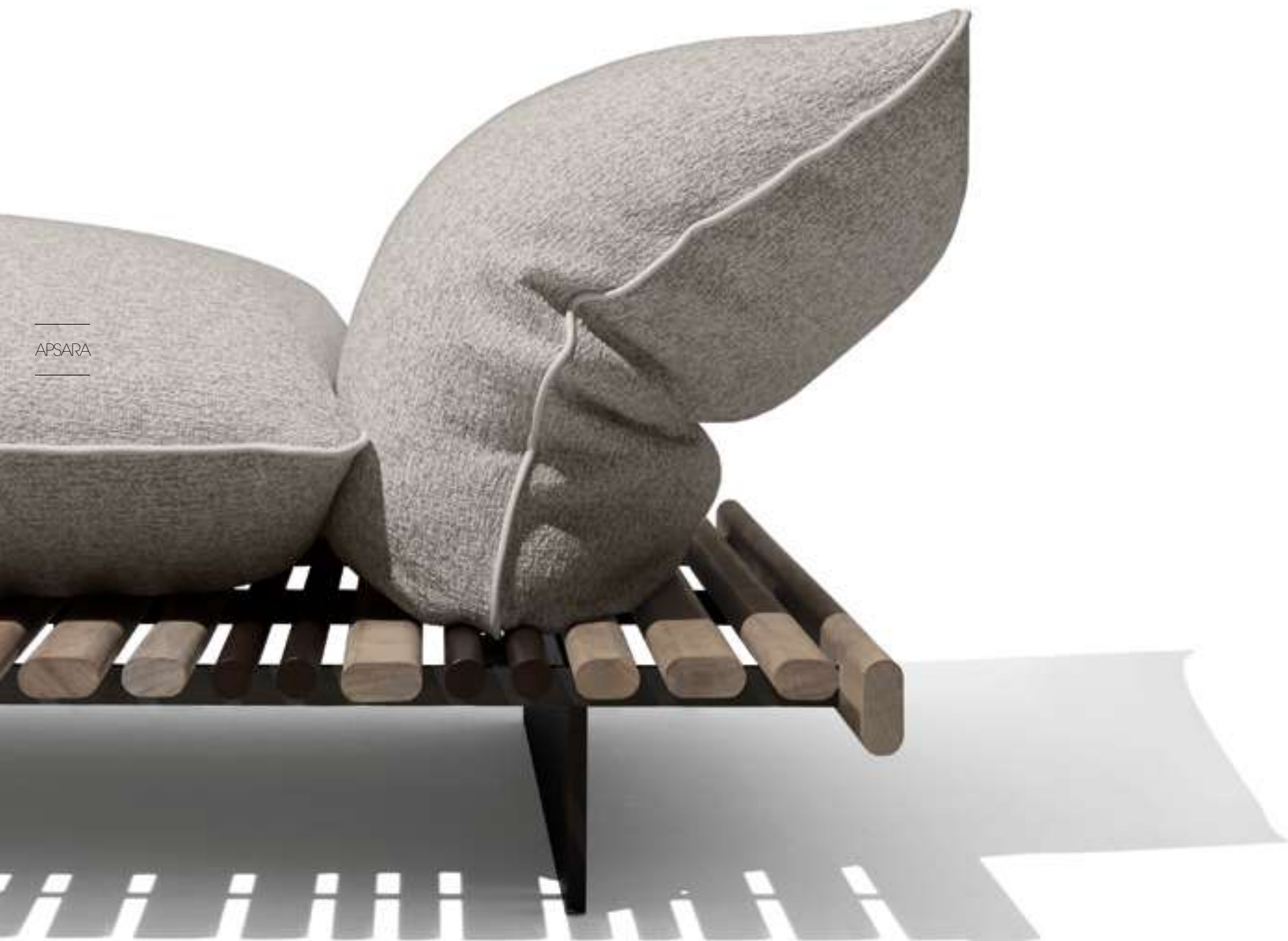

APSARA



526  
527



OPEN-AIR

---

# GEA

---

CHI WING LO 2017



262 > technical



530

531

GEA



532

533



OPEN-AIR

---

# GEA

---

CHI WING LO 2017



534  
535

OPEN-AIR

---

# BREAK

---

LUDOVICA+ROBERTO PALOMBA 2019



536

537

OPEN-AIR

---

**GEA**

---

CHI WING LO 2017



---

538  
539

---

GEA



540  
541



OPEN-AIR

---

# GEA

---

CHI WING LO 2017



OPEN-AIR

---

# GEA

---

CHI WING LO 2017



OPEN-AIR

---

# GEA

---

CHI WING LO 2017

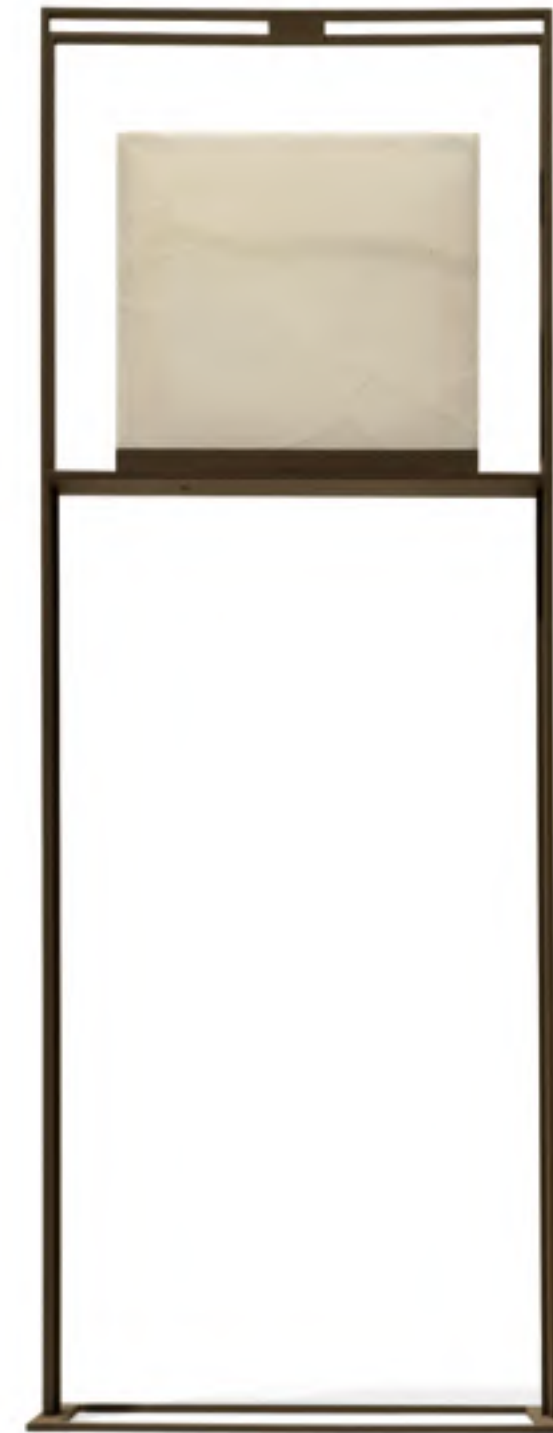

OPEN-AIR

---

**GEA**

---

CHI WING LO 2017



OPEN-AIR

GEA

CHI WING LO 2017



271 > technical



550

551





Giorgetti S.p.A.  
I 20821 Meda (MB)  
Via Manzoni 20  
T +39 0362 75275  
info@giorgetti.eu  
giorgetti.eu

IDEAZIONE E COORDINAMENTO  
Centro Ricerche e Immagine Giorgetti

FOTOGRAFIE  
Marco Beck Peccoz  
Sergio Chimenti  
Pesarini e Michetti  
Armando Rebbato  
Salvati e Salvati  
Alberto Tagliabue  
Max Zambelli

FOTOLITO  
De Pedrini

© giorgetti spa 2021  
giorgetti.eu



I diritti delle fotografie sono di proprietà degli autori e della Giorgetti S.p.A. È vietata la riproduzione anche solo parziale. Giorgetti S.p.A. si riserva il diritto di apportare le modifiche necessarie e migliorative ai prodotti qui illustrati, in qualsiasi momento e senza obbligo di preavviso. Le finiture riportate nella legenda dei singoli prodotti si riferiscono alla collezione Giorgetti aggiornata a Aprile 2021.

*All photos are copyrighted material and all rights are reserved to the respective photographer and to Giorgetti S.p.A. Photo reproduction in whole or in part is prohibited. Giorgetti S.p.A. reserves the right to make any necessary modifications and improvements to the products in these depictions, at any time and without prior notification. The finishes specified in the legend of the single products refer to the Giorgetti collection up-to-date as of April 2021.*

#Giorgetti

